



**LGMG North America Inc.**

# **Operation and Safety Manual**

---

---

**A45JE**

**Articulated Boom  
Mobile Elevating Work Platform  
ANSI**



## **WARNING**

**Before operation and maintenance, the drivers and service personnel shall always read and thoroughly understand all information in this manual. Failure to do so may result in, fatal accidents or personal injury.**

**This manual must be kept with this machine at all times.**

**This page left blank intentionally**

# Contents

Chapter 1 Safety .....	1
1.1 Danger.....	3
1.2 No operation is allowed unless .....	3
1.3 Classification of Hazards .....	3
1.4 Intended Purpose .....	3
1.5 Safety Sign Maintenance .....	4
1.6 Risk of Electric Shock .....	4
1.7 Risk of Tipping .....	4
1.8 Safety in the Work Area .....	4
1.9 Risk of Crushing .....	6
1.10 Risk of Operating on Slopes .....	6
1.11 Risk of Falling .....	6
1.12 Risk of Collision .....	6
1.13 Risk of Component Damage.....	7
1.14 Risk of Explosion and Fire .....	7
1.15 Risk of Vehicle Damage.....	7
1.16 Risk of Bodily Injury .....	7
1.17 Battery Safety .....	7
1.18 Ground Information.....	8
1.19 Locked after Each Use.....	9
1.20 Check Tires and Wheels .....	9
Chapter 2 Legend .....	11
Chapter 3 Decals .....	15
Chapter 4 Specification .....	23
Chapter 5 Control Unit.....	27
5.1 Lower Control Box .....	29
5.2 Upper Control Box .....	32
Chapter 6 Pre-Operation Inspection.....	37
6.1 No Operation Is Allowed Unless.....	39
6.2 Basic Principles .....	39
6.3 Pre-Operation Inspection .....	39
6.4 Checking the Battery .....	40
6.5 Checking the Hydraulic Oil Level .....	40
Chapter 7 Workplace Inspection .....	41
7.1 No Operation Is Allowed Unless.....	43
7.2 Basic Principles .....	43
7.3 Workplace Inspection.....	43

---

Chapter 8 Functional Test .....	45
8.1 No Operation Is Allowed Unless.....	47
8.2 Basic Principles .....	47
8.3 Functional Test.....	47
8.4 Tests from the Lower Control Box .....	47
8.5 Tests from the Upper Control Box .....	48
Chapter 9 Operating Instructions.....	51
9.1 No Operation Is Allowed Unless.....	53
9.2 Basic Principles .....	53
9.3 Emergency Stop .....	53
9.4 Auxiliary Power .....	53
9.5 Operation from the Ground Control Station.....	53
9.6 Operation from the Platform Control Station .....	54
9.7 Platform Overload Indicator .....	55
9.8 Tilt Indicator .....	55
9.9 Fall Protection Equipment.....	56
9.10 After Each Use.....	56
9.11 Instructions for Battery and Charger.....	56
9.12 Instructions for Skyguard .....	56
Chapter 10 Instructions for Transportation and Lifting .....	59
10.1 Compliance.....	61
10.2 Freewheel Configuration for Trailers .....	61
10.3 Transportation Safety.....	61
10.4 Lifting instructions .....	62

## Foreword

Thank you for choosing to use this Mobile Elevating Work Platform from LGMG North America. This machine is designed according to A92.20-2021. The information specified in this manual is intended for the safe and proper operation of this machine for its' intended purpose.

For maximum performance and utilization of this machine, thoroughly read and understand all the information in this manual before starting, operating, or performing maintenance on this machine.

Due to continuous product improvements, LGMG North America reserves the right to make specification changes without any prior notifications. For any updated information, contact LGMG North America.

Ensure all preventive maintenance to the machine is performed according to the interval specified in the maintenance schedule.

Keep this manual with this machine for reference at all times. When the ownership of this machine is transferred, this manual shall be transferred with this machine. This manual must be replaced immediately if it is lost, damaged, or becomes illegible.

This manual is copyrighted material. The reproduction or copy of this manual is not allowed without the written approval of LGMG North America.

The information, technical specifications and drawings in this manual are the latest available when this manual is issued. Due to continuous improvement, LGMG North America reserves the right to change the technical specifications and machine design without notice. If any specifications and information in the manual are not consistent with your machine, contact the service department of LGMG North America.

### **WARNING**

**Only personnel who have been properly trained and qualified to operate or maintain this machine can operate, repair and maintain this machine.**

**Improper operation, maintenance, and repair are dangerous and can cause personal injury and death.**

**Before any operation or maintenance, the operator shall thoroughly read this manual. Do not operate, perform any maintenance or make any repairs on this machine before reading and understanding this manual.**

**The user shall load the platform strictly according to the load rating of the platform. Do not overload the platform or make any modifications to the platform without permission from LGMG North America.**

**The operation regulations and preventions in this manual are only applicable for the specified use of this machine.**

# Safety Precautions

The operator of this machine shall understand and follow the existing safety regulations of state and local governments. If these are unavailable, the safety instructions in this manual shall be followed.

To help prevent accidents, read and understand all warnings and precautions in this manual before operation or performing maintenance.

The safety measures are specified in Chapter 1 Safety.

It is impossible to foresee every possible hazard and the safety instructions in this manual may not cover all safety prevention measures. Always ensure the safety of all personnel and protect the machine against any damage. If unable to confirm the safety of some operations, contact LGMG North America.

The operation & maintenance prevention measures listed in this manual are only applicable to the specified uses of this machine. LGMG North America assumes no responsibility if this machine is used beyond the range of this manual. The user and the operator shall be responsible for the safety of such operations.

Do not perform any operation forbidden in this manual in any situation.

The following signal words are applicable for identifying the level of safety information in this manual.

 **Danger:**

**An imminent situation, that if not avoided, will result in severe injuries or death. This is also applicable to situations that will cause serious machine damage, if not avoided.**

 **Warning:**

**A potentially dangerous situation, that if not avoided, may result in severe injuries or death. This is also applicable to situations that may cause serious machine damage, if not avoided.**

 **Notice:**

**A situation, that if not avoided, may result in minor or intermediate injury. This is also applicable to situations that may cause machine damage or shorten machine service life.**

# Chapter 1 Safety





## 1.1 Danger

Failure to follow the instructions and safety rules in this manual may cause death or serious injury.

## 1.2 No operation is allowed unless

You have understood and practiced the rules for safe operation of the vehicle in this manual.

- 1) Avoid dangerous situations. Know and understand the safety rules before proceeding with the next step.
- 2) Always perform a pre-operation inspection.
- 3) Always perform a pre-use functional test.
- 4) Check the workplace.
- 5) Use the vehicle only for its intended purpose.
- 6) Read, understand, and follow the manufacturer's instructions and safety rules - safe operation manuals and vehicle decals.
- 7) Read, understand and follow user safety rules and work site regulations.
- 8) Read, understand and follow all applicable government laws and regulations.
- 9) You have received the training on safe operation of the vehicle.

## 1.3 Classification of Hazards



**Classification of hazards**  
The meanings of symbols, color codes and characters of LGMG North America's products are as follows:

**Security warning symbol:** are used for warning of potential personal injuries.

Observe all safety instructions below these signs, to avoid situations causing potential personal injury and death.



**Red:** Signifies dangerous situations. If not avoided, will result in personal death or severe injury.



**Orange:** Signifies dangerous situations. If not avoided, may result in personal death or severe injury.



**Yellow:** Signifies dangerous situations. If not avoided, may result in minor or intermediate personal injury.

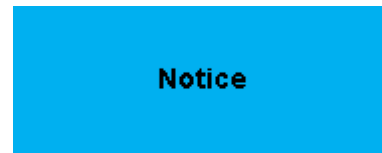

**Blue:** Signifies dangerous situations. If not avoided, property loss or damage can occur.

## 1.4 Intended Purpose

This vehicle is only used to lift operators and their tools and materials to high-altitude workplaces.



It is strictly forbidden to use the machine to carry loads.

## 1.5 Safety Sign Maintenance

- 1) The operators should always keep in mind their safety when replacing any missing or damaged safety signs.
- 2) The safety decal should be cleaned with mild soap and water.
- 3) Do not use solvent-based cleaners as they may damage the material of the safety decal.

## 1.6 Risk of Electric Shock

- 1) This vehicle is not insulated and is not provided with electrical shock protection when it comes into contact with or near electrical wire.

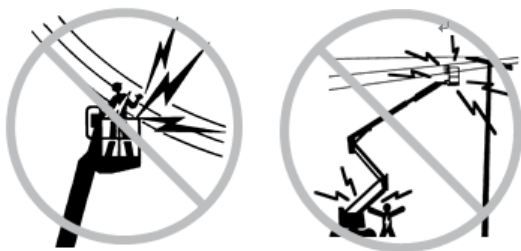

- 2) This vehicle should be kept an adequate safety distance from power line and electrical equipment according to applicable government laws and regulations and the following table.

Voltage	Required clearance
0V~50KV	10ft
50KV~200KV	15ft
200KV~350KV	20ft
350KV~500KV	25ft
500KV~750KV	35ft
750KV~1000KV	45ft

- 3) The effects of strong winds or gusts on the movement of the platform, the swinging and slackening of the wires should be considered.
- 4) If the vehicle comes into contact with live wires, keep away from the vehicle. No one is allowed to touch or operate the vehicle on the ground or platform before cutting off

the power supply.

- 5) Do not operate the vehicle during lightning or storms.
- 6) Do not use the machine as a ground wire when welding.

## 1.7 Risk of Tipping

The personnel, equipment and materials on the platform may not exceed the maximum load capacity of the platform.

Model	A45JE
Maximum number of people	2 people
Maximum allowable wind speed	12.5m/s/28mph
Maximum platform working load	230kg/510lbs

## 1.8 Safety in the Work Area

- 1) The boom can be lifted or extended only when the vehicle is on a solid, flat surface.

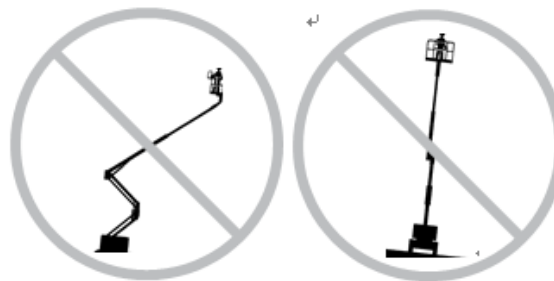

- 2) When the platform is lifted, drive speed may not exceed 0.62mph.
- 3) The tilt sensor may not be used as a level indicator. The alarm on the turntable will sound only when the vehicle is heavily tilted.
- 4) When the alarm sounds: Do not extend, rotate or lift the boom beyond the horizontal plane. The vehicle should be moved to a solid, level surface before lifting the platform. If the alarm sounds when lifting the platform, the boom should be telescoped carefully and the platform should be lowered. Do not rotate the boom during lowering. The vehicle should be moved to a solid, flat surface before lifting the platform.

- 5) For outdoor operation, do not lift the boom when the wind speed may exceed 28mph. If the wind speed exceeds 28mph. after the boom is lifted, the boom should be lowered and do not continue to operate the vehicle.
- 6) Do not operate the vehicle in strong winds or gusts. Do not increase the surface area of the platform or load. Increasing the area exposed to the wind will reduce the stability of the vehicle.
- 7) Do not operate the vehicle with the upper control box when the platform is caught, jammed, or other nearby objects are blocking its normal movement. If you want to operate the vehicle with the lower control box, you must operate it after all personnel have left the platform.
- 8) In the telescoped state, the vehicle should be operated carefully and slow down when driving on uneven terrain, gravel, unstable or smooth surfaces, near holes or steep slopes.



- 9) When the boom is lifted or extended, the vehicle may not drive on uneven terrain, unstable surfaces, or other dangerous conditions, or near these areas.
- 10) Do not push or pull any object that is outside the platform.
- 11) Do not use the vehicle as a crane.
- 12) Do not place, tie, or hang any loads on any part of the vehicle.



- 13) Do not use the boom to push the vehicle or other object.
- 14) Do not operate the vehicle with the battery

tray open.

- 15) Do not make the boom contact adjacent components.
- 16) The limit button switch may not be changed or disabled.
- 17) The boom or platform may not be tied to adjacent components.
- 18) The load may not be placed outside the perimeter of the platform.
- 19) Do not modify the elevating work platform without the prior written permission of the manufacturer. Installing additional equipment for placing tools or other materials on the platform, pedal plate or guardrail will increase the weight of the platform and the surface area of the platform or increase the load.
- 20) Do not modify or damage any parts that may affect the safety and stability of the vehicle.
- 21) Key parts that affect the vehicle's stability may not be replaced with parts of different weights or specifications.
- 22) Do not use any battery that weighs less than the original battery. The battery not only acts as a counterweight, but also is essential for maintaining the stability of the vehicle. The weight of each battery must reach 47kg/104lbs, and the minimum weight of each battery tray (including battery) must reach 249kg/549 lbs
- 23) Do not place the ladder or scaffolding in the platform or against any part of the vehicle.
- 24) Only tools and materials that are evenly distributed and can be safely moved by people on the platform can be transported.
- 25) Do not operate the vehicle on a moving surface or on a vehicle.
- 26) Make sure all tires are in good conditions and the nuts are properly tightened.
- 27) The ambient temperature in which the vehicle can be operated is -13°F ~104°F.
- 28) The allowable fluctuation of the vehicle's supply voltage is ±10%.

## 1.9 Risk of Crushing

- 1) Do not place arms, hands, or fingers in any position where there is a hazard of potential crushing.
- 2) When the machine is being operated from the ground using the control unit, use good judgment and carefully plan the travel path of the machine and boom. Keep a safe distance between the operator, machine and any fixed objects, walls, or buildings.

## 1.10 Risk of Operating on Slopes

Do not drive the vehicle on a slope that exceeds the vehicle's slope and side slope ratings. The slope rating applies to the vehicle that is in the retracted state.

Maximum slope rating, stowed position

Platform downhill	30% (17°)
Platform uphill	25% (14°)
Side slope	25% (14°)



**Warning:**

**When the vehicle is going downhill, select the medium speed mode (turtle) or the slow speed mode (snail) set at the upper control!**

## 1.11 Risk of Falling

- 1) During operation, the personnel on the platform must wear the full body safety harness and secure it with a seat belt hook to the approved rope attachment point. Only one hook can be tied to each rope attachment point.
- 2) Do not sit, stand or climb on the guardrail of the platform. Always stand on the platform floor firmly.



- 3) After the platform is lifted, the operator may not climb down the boom.
- 4) Keep the platform floor free of debris.
- 5) Lower the platform entry lifting rod or close the entry door before operating.
- 6) Do not operate the vehicle if the guardrail is not installed properly or the entrance door fails to guarantee safe operation.
- 7) Do not enter or exit the platform unless the machine is in the stowed position.

## 1.12 Risk of Collision

- 1) When starting or operating the vehicle, pay attention to the blind spots within the line of sight.
- 2) When rotating the turntable, pay attention to the position of the boom and the tail of the turntable.
- 3) Check the work area to avoid obstacles or other possible hazards.

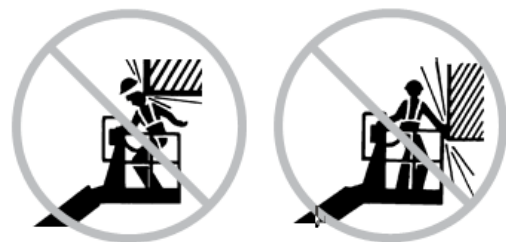

- 4) When grabbing the platform guardrail, be careful of the risk of squeezing.
- 5) Lower the boom when there are no people or obstacles in the area underneath.



- 6) Limit the drive speed according to the

ground conditions, congestion levels, slope, personnel location and any other factors that may cause a collision.

- 7) It is not allowed to operate the vehicle on any crane or moving overhead vehicle route unless the crane control unit has been locked and/or precautions have been taken to prevent any potential collision.
- 8) When operating the vehicle, avoid any dangerous behaviors.
- 9) Users must abide by user rules, workplace rules and government rules regarding the use of personal protective equipment.
- 10) The direction arrows of the drive and steering function of the upper control box should be noted.

## 1.13 Risk of Component

### Damage

- 1) It is not allowed to charge the battery with any battery charger greater than the maximum output voltage of 48V or quick charge in a short time.
- 2) Do not use the vehicle as a ground wire when welding.

## 1.14 Risk of Explosion and

### Fire

Do not operate the vehicle where it is dangerous or where flammable or explosive gases or particles may be present.

## 1.15 Risk of Vehicle Damage

- 1) Do not operate a vehicle that is damaged or faulty.
- 2) Before each work shift, thoroughly perform the pre-operation inspection against the vehicle and test all functions. A damaged or faulty vehicle should be immediately tagged out and stopped.
- 3) Make sure all maintenance operations have

been performed as specified in this manual.

- 4) Make sure all decals are properly positioned and easily identifiable.
- 5) Make sure this manual is stored in the manual box on the platform.

## 1.16 Risk of Bodily Injury

- 1) Do not operate the vehicle with hydraulic oil leaks, which may penetrate when under pressure or burn your skin.
- 2) Incorrect contact with any component under the cover may cause serious injury. Only qualified authorized service personnel can access the compartment. It is recommended that the operator perform the inspection only during the pre-operation inspection. All compartments must be closed and locked during operation.

## 1.17 Battery Safety

### Risk of Burns

- 1) The battery contains acidic substances. Wear protective clothing and goggles when maintaining the battery.



- 2) Avoid spilling or touching the acid in the battery. Soda and water can be used to neutralize the spilled battery acid.
- 3) The battery pack must be placed vertically.
- 4) Do not expose the battery or charger to water or rain.
- 5) When the vehicle is not operated for a long time, turn off the main power switch.



### Risk of Explosion



- 1) Sparks, flames and lit cigarettes are prohibited from getting close to the battery. The battery can release explosive gases.
- 2) The battery pack cover must remain open throughout the charging process.
- 3) Do not touch the battery terminals or cable clamps with tools that may cause sparks.

### Risk of Component Damage

- 1) Do not charge the battery with any battery charger that is greater than the maximum output voltage of 48V.
- 2) The battery pack must be charged together.
- 3) The battery pack pin should be disconnected before removing the battery pack.

### Risk of Electric Shock/Burn

- 1) Connect the battery charger to a grounded AC three-wire power outlet only.
- 2) Check the lines, cables and wires for damage daily. Replace the damaged items before operation.
- 3) Avoid electric shock due to contact with battery terminals. Remove all rings, watches and other accessories.

### Risk of Tipping

Do not use any battery that weighs less than the original battery. The battery not only acts as a counterweight in the chassis, but also is

essential for maintaining the stability of the vehicle. Each battery must weigh 47kg/104lbs. The minimum weight of each battery tray (including battery) must reach 249kg/549lbs.

### Danger during lifting

Remove or install the battery pack with a fork.

## 1.18 Ground Information

**⚠️ WARNING:** Rollover and personal injury will be caused under severe working conditions and complex and unsafe ground conditions, and stable ground conditions and good working conditions can ensure the normal operation of the machine; therefore before operation, verify that the ground in the working area is safe and strong enough to support the machine.

**⚠️ DANGER:** Rollover and personal injury may occur under the following conditions:

- on steep slopes or in caves;
- when there are protrusions, obstacles or debris on the ground;
- on the inclined surface;
- on the unstable or smooth surface;
- near the mining area where the soil foundation is soft soil;
- on saturated soil or frozen soil;
- on suspended floor;
- on kerbs and road edges;
- on surface support that is not strong enough to withstand the full load of the machine;
- under other possible unsafe situations.

The ground load bearing information of the machine is shown in the table below:

Model	Tire contact pressure (kPa/Psi)	Occupied floor pressure (KpaPsi/)
A45JE	820.8/119	14.7/2.1

 **CAUTION: The ground load**

bearing information given herein is for reference only, and does not consider the optional devices of the machine. Before using the machine, always verify that the ground of the working area is safe and strong enough to support the machine.

**Tire specification:**

Model	Drive wheel load-6km/h (Kg/lbs)	Maximum static load (Kg/lbs)
A45JE	3600/7937	4500/9921

## 1.19 Locked after Each Use

- 1) Choose a safe parking location that can be a solid, flat surface without obstructions or heavy traffic.
- 2) Telescope the boom and lower the platform.
- 3) Rotate the turntable so that the boom is between the non-steer wheels.
- 4) Turn the key switch to the "OFF" position and remove the key to avoid any unauthorized use.
- 5) Block the wheel with a wedge.
- 6) Charge the battery.

## 1.20 Check Tires and Wheels

This check item is conducted every 250 hours or once per quarter, whichever comes first.

Keeping tires and wheels in a good condition is critical for safe operation and good performance. Failure of the tires and wheels may cause the platform to tilt. If such failure is not found and repaired in time, it will also cause damage to platform parts.

- 1) Check treads and sides of tires for scratches, cracks, punctures, and other abnormal

wear.

- 2) Check if the wheels are damaged, bent or cracked.
- 3) Check whether or not the sealing screws for tires are missing. If missing screws, if there is slight or no leakage of fillers, and no significant deformation is found for the tire body, and users can knock in screws which are slightly larger than the diameter (about 5mm/2in) of the vent hole with a hammer. If leakage of a large quantity of filler is found, and the tire body deforms significantly, lower the platform and replace the tires immediately.





## Chapter 2 Legend



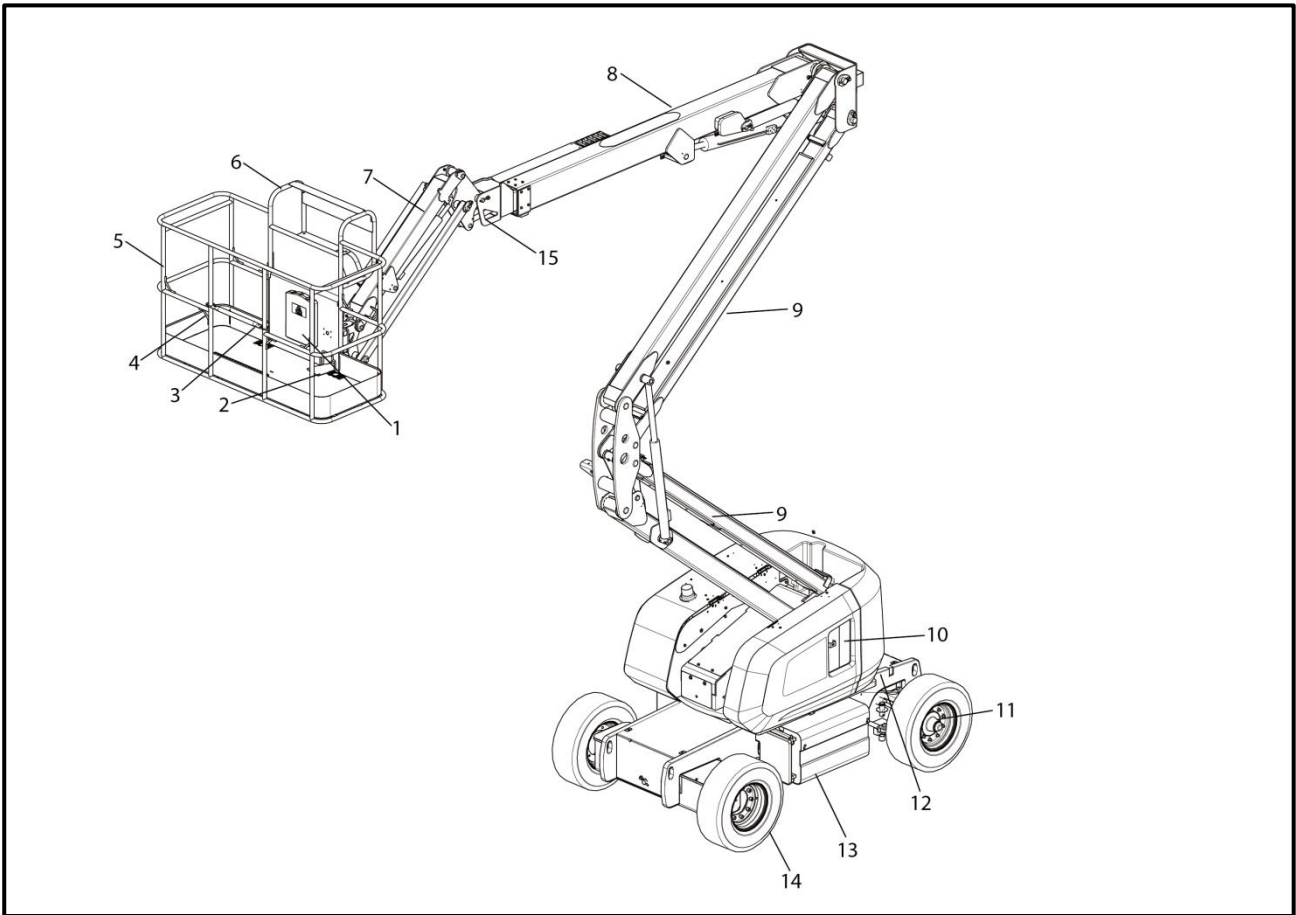

No.	Name	No.	Name
1	File box	10	Lower control box
2	Foot switch	11	Steering wheel
3	Lifting rod	12	Charger
4	Lanyard fixing point	13	Battery box
5	Platform	14	Non-steering wheel
6	Upper control box	15	Fly boom section
7	Jib		
8	Base boom section		
9	Tower boom section		



## Chapter 3 Decals



Decal

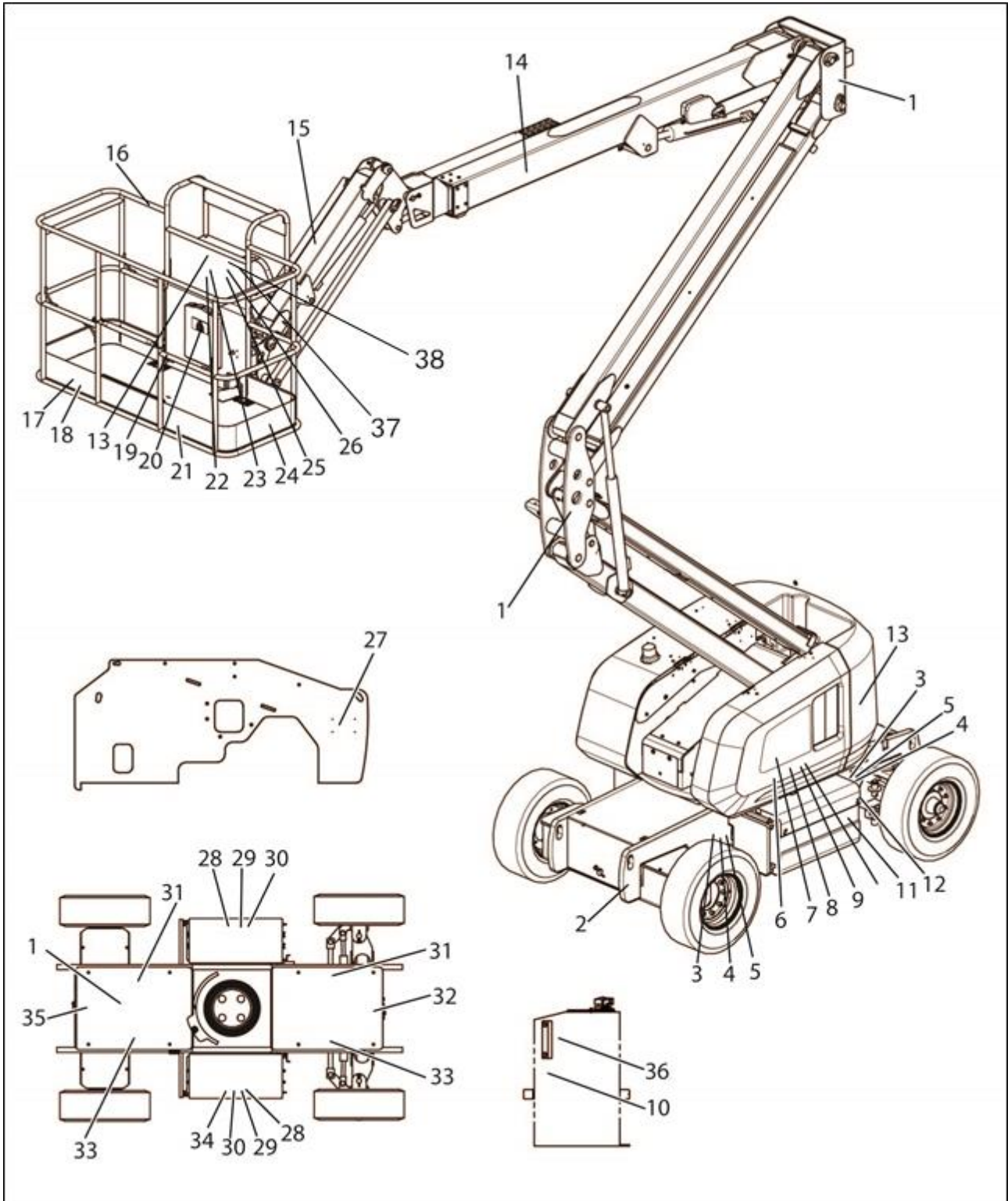

1-2534001545



2-2534001178



3-2534001575



4-2534001549



5-2534001578



6-2534001543



7-2534000189



8-2534001548



9-2534000998



10-2534001995



11-2534001573

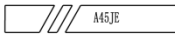

12-2534001564



13-2534001540

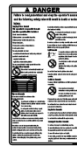

14-2534001749



15-2534001180



16-2534000017



17-2534001559

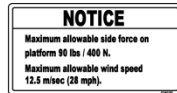

18-2534001560

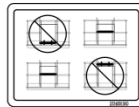

19-2534000248



20-2534001542

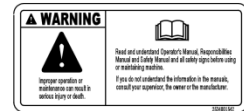

21-2534001565



22-2534001762



23-2534001541



24-2534000024



25-2534001570



26-2534000026



27-2534001526

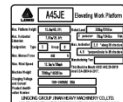

28-2534001547



29-2534001546

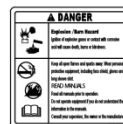

30-2534001563

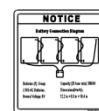

31-2534000051



32-2534000053



33-2534000050



34-2534001558



35-2534000052



36-2534001377



37-2534002552



38-2534002553

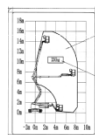



**Decal List**

No.	Code	Name
1	2534001545	Tip Over Hazard Sign
2	2534001178	Lanyard Fixing Point Sign
3	2534001575	Tire Instruction Sign
4	2534001549	Wheel Load Sign
5	2534001578	Anti-Rollover Attention Sign
6	2534001543	Anti-Crashing Danger Sign
7	2534000189	Group LOGO-Lift
8	2534001548	Shock Hazard Sign
9	2534000998	No Spark Sign
10	2534001995	Hydraulic Oil Sign
11	2534001573	Right Box Model Sign – A45JE
12	2534001564	Component Damage Hazard Sign
13	2534001540	Security Rule Specification Sign
14	2534001749	Group LOGO
15	2534001180	Anti-Falling Attention Sign
16	2534000017	Lanyard Fixing Point Sign
17	2534001559	Maximum Hand Power Sign
18	2534001560	Middle Guardrail Lowering Attention Sign
19	2534000248	Anti-Scratch
20	2534001542	Instructions Reading Sign
21	2534001565	Platform Security Warning Sign
22	2534001762	Non-Insulating
23	2534001541	Uphill And Downhill Tipping Attention Sign
24	2534000024	Warning Line
25	2534001570	Lost Manual Instruction
26	2534000026	Instructions Reading Sign
27	2534001526	Vehicle Nameplate
28	2534001547	Battery Counterweight Warning Sign
29	2534001546	Explosion Burn Warning Sign
30	2534001563	Battery Connection Sign
31	2534000051	Arrow Sign
32	2534000053	Arrow Sign
33	2534000050	Arrow Sign
34	2534001558	Hazardous Material Sign
35	2534000052	Arrow Sign
36	2534001377	Hydraulic Oil Level Sign
37	2534002552	Label-slop rating
38	2534002553	Label-range of motion

Decal

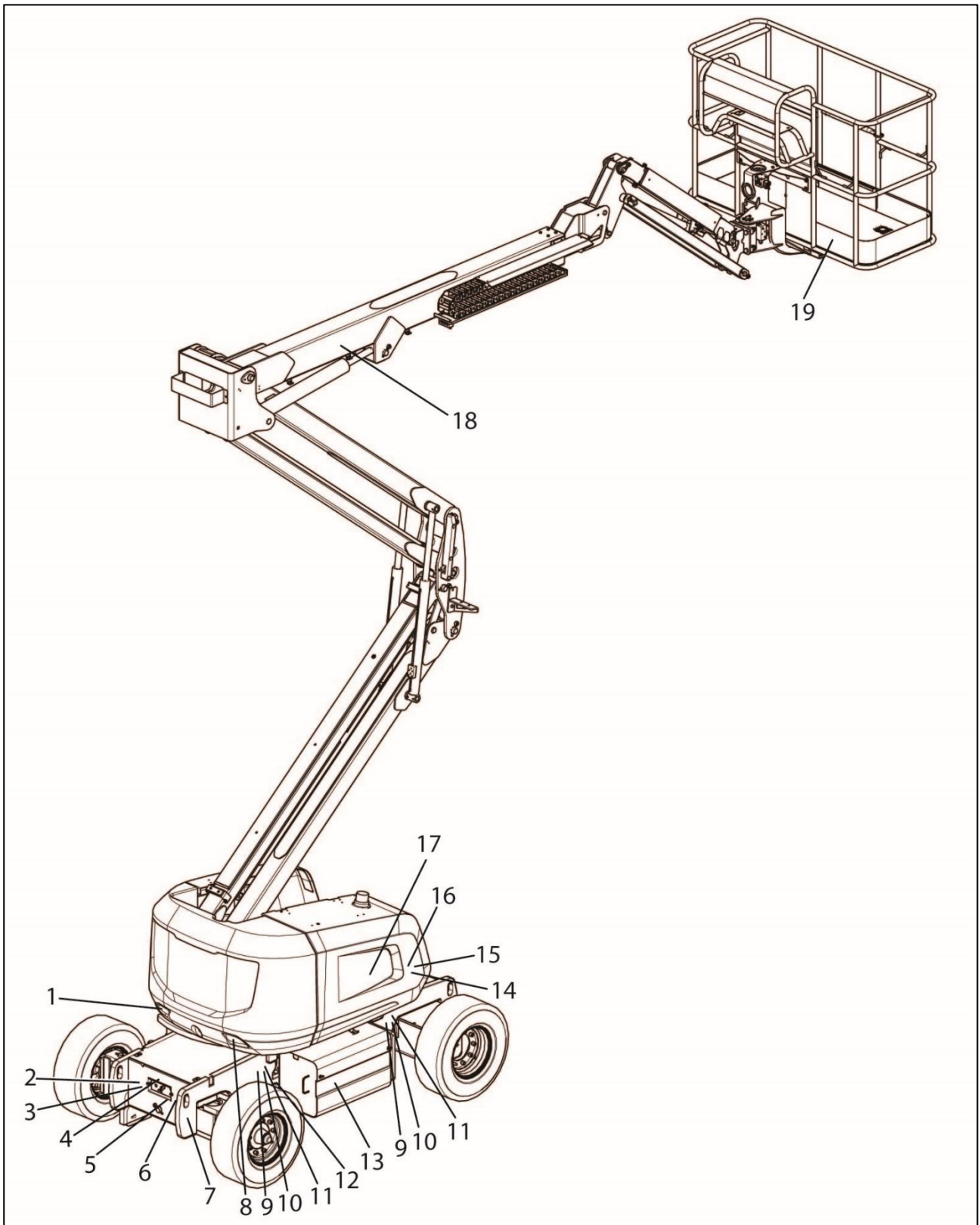

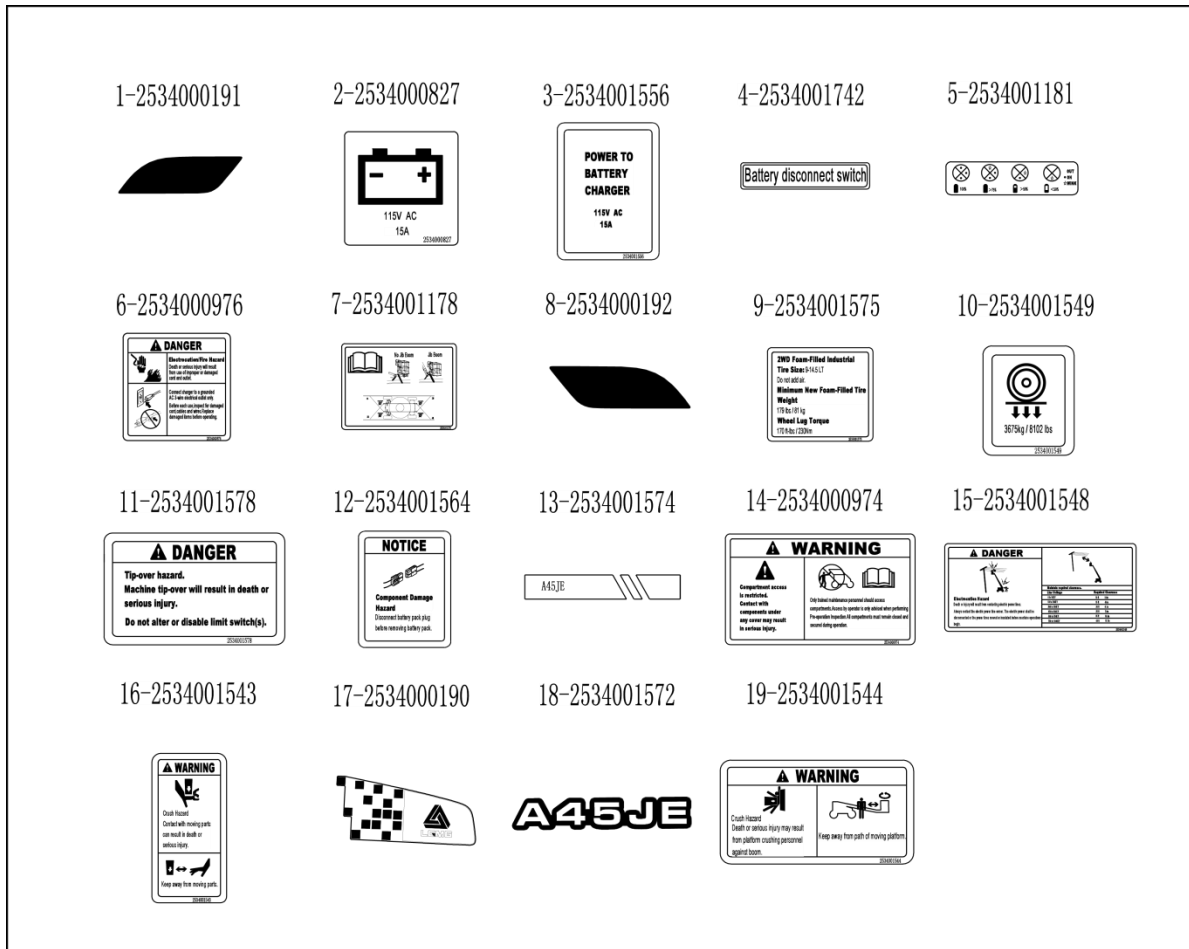

No.	Code	Name
1	2534000191	Reflective Sticker
2	2534000827	Battery Charging Sign
3	2534001556	Battery Charging Sign
4	2534001742	Power Switch Sign
5	2534001181	Charging Indicator Sign
6	2534000976	Electric Shock Warning Sign
7	2534001178	Lanyard Fixing Point Sign
8	2534000192	Reflective Sticker
9	2534001575	Tire Instruction Sign
10	2534001549	Wheel Load Sign
11	2534001578	Anti-Rollover Attention Sign
12	2534001564	Component Damage Hazard Sign
13	2534001574	Left Box Model Sign – A45JE
14	2534000974	In-Box Maintenance Attention Sign
15	2534001548	Shock Hazard Sign
16	2534001543	Anti-Crashing Danger Sign
17	2534000190	Group LOGO-Right
18	2534001572	Model Sign – A45JE
19	2534001544	Keeping Away From Vehicle Warning Sign



## Chapter 4 Specification



### A45JE Specifications

#### 4.1 Performance Specifications

Item	Specification	Item	Specification
Rated load (kg/lbs)	230/510	Turntable rotation by one circle (s)	95-125
Vehicle weight (kg/lbs)	7500/16535	Boom lifting (s)	32-40
Maximum number of people	2	Boom lowering (s)	26-30
Maximum working height (m/ft)	15.8/51.8	Tower boom lifting (s)	40-52
Maximum platform height (m/ft)	13.8/45.3	Tower boom lowering (s)	38-46
Maximum horizontal extension (m/ft)	7.81/25.6	Telescopic boom extended (s)	22-28
Maximum span height (m/ft)	7.26/23.8	Telescopic boom telescoped (s)	25-28
Turning radius(outside)(m/ft)	4.1/13.5	Jib lifting (s)	38-50
Turning radius(inside) (m/ft)	1.83/6	Jib lowering (s)	22-28
Vehicle speed (in the telescoped state) (km/h/mpH)	4.8±0.25/ 3±0.16	Platform rotation (s)	6-12
Vehicle speed (in the lifted state) (km/h/mpH)	1±0.05 0.62±0.03	Maximum manual force(N)	400
Maximum allowable tilt angle	3°	Maximum allowed wind speed (m/s/mpH)	12.5/28
Theoretical climbing ability	30%		

#### 4.2 Dimensions

Item	Specification	Item	Specification
Vehicle length (m/ft)	6.66/21.9	Track width (mm/in)	1559/61
Vehicle width (m/ft)	1.8/5.9	Wheelbase (mm/in)	2030/80
Vehicle height (m/ft)	1.98/6.5	Ground clearance (in the telescoped state) (m/ft)	0.24/0.79
Working platform size (LxW) (m/ft)	1.83x0.76 6x2.5	Tire specifications(Diameter×width)(mm/in)	714×237/ 28.1×9.3

#### 4.3 Hydraulic System

Item	Specification/Content
Type	Open system
Displacement of main pump (ml/r)	3
Displacement of rotary motor(ml/r)	475
System pressure (MPa/psi)	23.5/3408

#### 4.4 Electrical System

Item	Specification/Content
Functional motor	Rated power (kW) 2.6
Drive motor	Rated power (kW) 3.56
Battery(Total)	Output voltage (Vdc) 48
	Capacity (Ah) 390

Charger	Nominal DC output voltage (V)	48
---------	-------------------------------	----

### 4.5 Transmission system

Item		Parameter/Content
Driving reducer	Output torque(Nm)	2825
Rotary reducer	Output torque(Nm)	820

### 4.6 Oil Capacity

Item	Specification
Hydraulic oil(L/gal)	30/7.9
Gear oil(each reducer)(L/gal)	0.68×2/0.18×2

Note: When hydraulic oil and diesel are filled, it is necessary to use the corresponding hydraulic oil and diesel according to operating environment and temperature, and refer to the following contents:

Item	Condition	Oil viscosity brand	Capacity	Remarks
Hydraulic oil(L)	The lowest temperature > -25 °C	L-HV32 Low temperature hydraulic oil	30	Recomm ended chevron brand
	-40 °C < The lowest temperature ≤ -25 °C	L-HS32 Ultra low temperature hydraulic oil		
	The lowest temperature ≤ -40 °C	10# Aviation hydraulic oil		
Reducer oil(L)	30° C < The lowest temperature	85W/140	0.68×2	SAE API 1560 GL-5
	-10° C < The lowest temperature < 30° C	85W/90		
	-30° C < The lowest temperature < -10° C	80W/90		
	The lowest temperature < -30° C	75W		

### 4.7 Range of motion

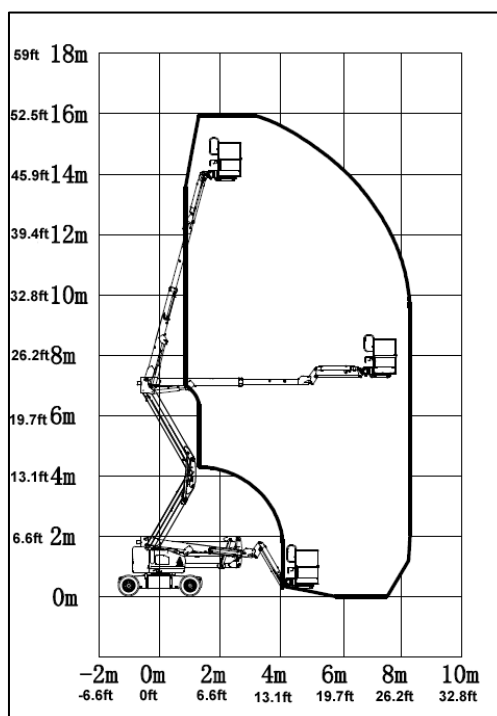



## Chapter 5 Control Unit





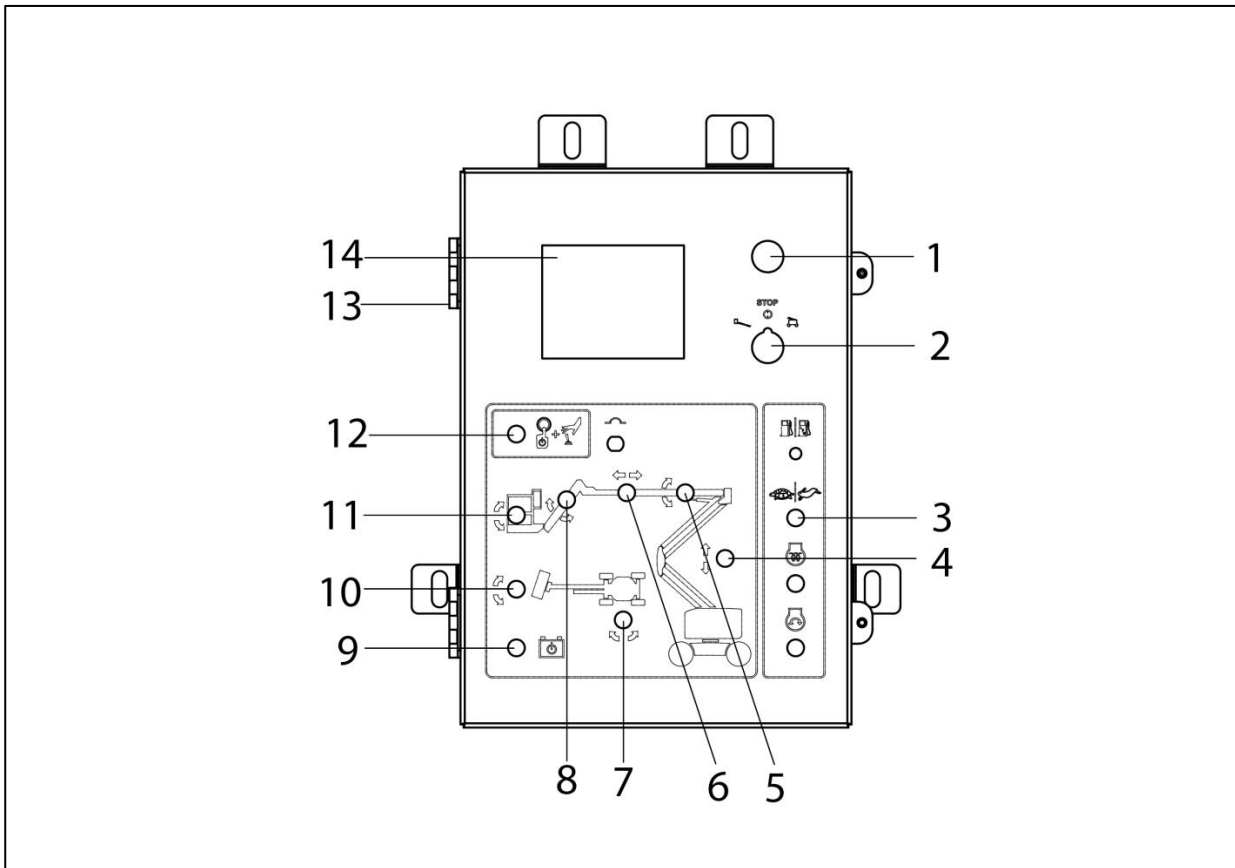





## 5.1 Lower Control Box



No.	Name	No.	Name
1	Emergency stop button switch	8	Jib boom up/down switch
2	Key button switch	9	Auxiliary power button switch
3	Reserved	10	Platform rotary button
4	Tower boom up/down switch	11	Platform leveling button
5	Base boom up/down switch	12	Function enable button switch
6	Base boom extend/retract switch	13	Hinge
7	Turntable rotary button	14	Display

The functional description of the lower control box button switch is as follows:

Item	Button switch	Functional description	
Lower Control Box	Key Button Switch	When turning the key switch to the "Platform" position, the upper control box will be enabled. When turning the key switch to the "OFF" position, the vehicle will stop. Turn the key switch to the "Ground" position and the lower control box will be enabled.	
	Emergency Stop Button Switch	When pushing the red "Emergency Stop" button inward to the "OFF" position, all functions can be disabled. When each function control handle or button switch of the vehicle is enabled, all functions will not be enabled.	
		When pulling the red "Emergency Stop" button to the "ON" position, the vehicle can be operated and the warning light should flash.	
	Function Enable Button Switch	Do not press and hold the function enable dial switch, try to activate each boom and platform function button switch. The boom and platform functions will not be enabled.	
		When pressing and holding the function enable button and activating each boom and platform function button switch, the boom and platform functions should operate for a full cycle.	
	<ol style="list-style-type: none"> <li>1. Turn the key button switch to the lower control box.</li> <li>2. Pull the red "Emergency Stop" button outward to the "ON" position.</li> <li>3. Press and hold the enable button.</li> </ol>		
	Platform rotary button	 When pulling the button switch upward, the platform will rotate to the left. When pulling the button switch downward, the platform will rotate to the right.	
	Turntable rotary button	 When turning the button switch to the right, the turntable will move to the right. When moving the button to the left, the turntable will move to the left.	
	Base boom up/down button	 When pulling the button switch upward, the boom will be lifted. When pulling the button switch downward, the boom will be lowered. The lowering alarm should sound when the boom is lowered.	
	Base boom extend/retract button	 When pulling the button switch to the left, the boom will be extended. When pressing the button switch to the right, the boom will be telescoped.	
Tower boom up/down button	 When pulling the button switch upward, the tower boom will be lifted. When pulling the button switch downward, the tower boom will be lowered. The lowering alarm should sound when the boom is lowered.		





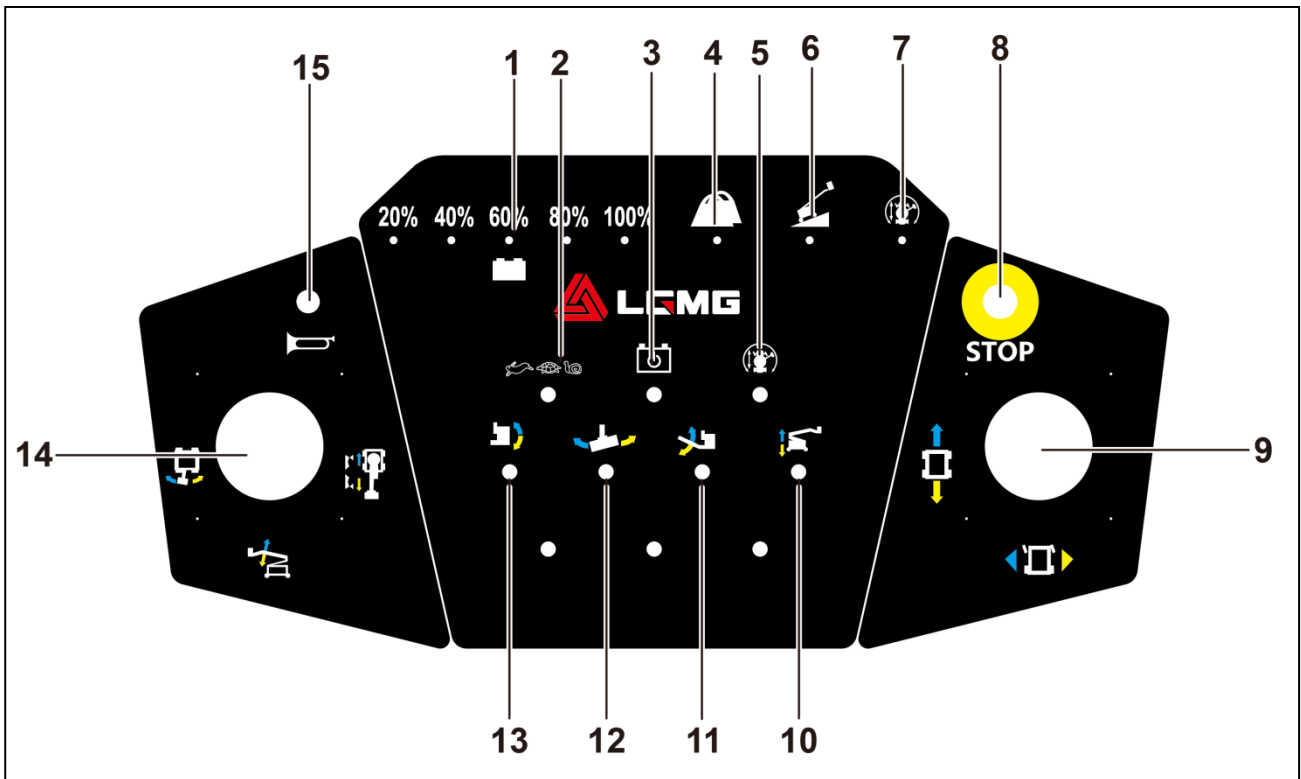

Item	Button switch	Functional description	
Lower Control; box	Jib boom up/down button		When pulling the button switch upward, the jib boom will be lifted. When pulling the button switch downward, the jib boom will be lowered.
	Platform leveling button		When pulling the platform leveling button switch upward, the platform level will be lifted. When pulling the platform leveling button switch downward, the platform level will drop.
	Auxiliary power button switch		<ol style="list-style-type: none"> <li>1. Turn the key switch to the lower control box.</li> <li>2. Pull the red "Emergency Stop" button outward to the "ON" position.</li> <li>3. Pull the auxiliary power button switch to either side and repeat the above procedure.</li> </ol> <p>All boom functions should be normal.</p>



## 5.2 Upper Control Box



No.	Name	No.	Name
1	Battery indicator	9	Drive/steering control handle
2	Speed select button	10	Tower boom luffing button
3	Auxiliary power button switch	11	Jib boom luffing button
4	Platform overload alarm	12	Platform rotary button
5	Drive enable button	13	Platform up/down leveling button
6	Machine tilt alarm	14	Base boom section lifting/lowering/extending/telescoping and turntable left/right rotation
7	Drive enable indicator	15	Horn button
8	Emergency stop button switch		

The functional description of the upper control box button switch is as follows:

Item	Button switch	Functional description	
Upper control box	Emergency stop button switch	<p>When pushing the red “Emergency Stop” button inward to the “OFF” position, all functions can be disabled. When each function control handle or button switch of the vehicle is activated, all functions cannot be enabled.</p> <p>When the red "Emergency Stop" button is pulled to the “ON” position, the vehicle can be operated.</p>	
	Foot switch	<p>The foot switch may not be pressed and each function of the vehicle should be enabled. As a result, the vehicle function cannot be enabled.</p> <p>When the foot switch is pressed to activate each function control handle or button switch of the vehicle, all boom and platform functions should operate for a full cycle.</p>	
	Horn button	<p>When the horn button is pressed, the horn will sound. When the horn button is released, the horn will stop ringing.</p>	
	<ol style="list-style-type: none"> <li>1. Turn the key button switch to the upper control box.</li> <li>2. Pull the red “Emergency Stop” button outward to the “ON” position.</li> <li>3. Press the foot switch.</li> </ol>		
	Platform Swing button switch	 <p>When moving the platform Swing button switch to the right, the platform will rotate to the right. When moving the platform rotation button switch to the left, the platform will rotate to the left.</p>	
	Base boom section lifting/lowering/extending/telescoping and turntable left/right rotation	 <p>When moving the control handle to the right, the turntable will move to the right. When moving the control handle to the left, the turntable will move to the left.</p>	
		 <p>When moving the control handle up, the boom will be lifted. When moving the control handle downward, the boom will be lowered. The lowering alarm should sound when the boom is lowered.</p>	
		 <p>When pressing the lower side of the thumb rocker, the boom will be extended. When pressing the upper side of the thumb rocker, the boom will be telescoped.</p>	
	Tower boom section lifting/lowering button switch	 <p>When pulling the button switch upward, the tower boom will be lifted. When pulling the button switch downward, the tower boom will be lowered. The lowering alarm should sound when the boom is lowered.</p>	
	Jib boom lifting/lowering switch	 <p>When pulling the button switch upward, the jib boom will be lifted. When pulling the button switch downward, the jib boom will be lowered.</p>	
Platform leveling switch	 <p>When pulling the platform leveling button switch upward, the platform level will be lifted. When pulling the platform leveling button switch downward, the platform level will drop.</p>		

	Drive/steer control handle	When moving the control handle upward, the vehicle will drive forward. When moving the control handle downward, the vehicle will drive backward. When pressing the left side of the thumb rocker, the vehicle will turn to the left. When pressing the right side of the thumb rocker, the vehicle will turn to the right.
	Drive enable button	 <p>Press the foot switch and lower the boom to the telescoped position. Rotate the turntable until the boom moves over more than one non-steering wheel. As a result, the drive enable indicator should be lit at any position within the range shown in the figure. When moving the drive control handle to the center position, the drive function will not be enabled. When moving the drive enable button switch to one side and slowly moving the drive control handle away from the center position, the drive function should be enabled.</p> <p>Note: When operating the drive enable system, the vehicle can drive in the opposite direction of drive and steering control handle movement.</p>
	Speed regulation switch	 <p>Select the different speed modes to increase or decrease the vehicle speed</p>
	Auxiliary power switch	 <ol style="list-style-type: none"> <li>1. Turn the key button switch to the platform control unit.</li> <li>2. Pull the red “Emergency Stop” button outward to the “ON” position.</li> <li>3. Press the foot switch.</li> <li>4. Pull the auxiliary power button switch to either side and repeat the above procedure.</li> </ol> <p>All boom functions should be normal. The drive function may not work with the auxiliary power supply.</p>

System fault code and fault diagnosis

Display	Error code	Description and solution
EVERYTHING OK 0/0	0/0	Normal
GROUND MODE ACTIVE!,0/0	0/0	Ground mode
STARTUP!,0/0	0/0	Startup
MOVING PLATFORM!,0/0	0/0	Moving platform
MOVING JIB!,0/0	0/0	Moving jib
SWINGING!,0/0	0/0	Swinging
TELESCOPING!,0/0	0/0	Telescoping
LIFTING!,0/0	0/0	Lifting
LOWERING!,0/0	0/0	Lowering
DRIVING!, 0/0	0/0	Driving
RELEASE FSW!, 2/2	2/2	Foot switch
NOT CALIBRATED, 1/1	1/1	No calibrated
HEIGHT NOT CALIBRATED, 1/1	1/1	Height is not calibrated
VEHICLE TILTED, 0/0	0/0	Vehicle tilt



FUNCTIONS LOCKED - TEST MODE SELECTED, 2/2	2/2	Function lock, select test mode
SOME FUNCTIONS MUST BE USED ALONE!, 2/2	2/2	Some functions must be used alone
FUNCTIONS LOCKED - EMERGENCY PUMP, 2/2	2/2	Function lock - emergency pump
FUNCTIONS LOCKED -ARMGUARD, 2/2	2/2	Function lock - anti-pinch
FUNCTIONS LOCKED - OVERLOADED, 2/2	2/2	Function lock - overload
FUNCTIONS LOCKED - UNDERLOADED, 2/2	2/2	Function lock - underload
FUNCTIONS LOCKED - TILTED, 2/2	2/2	Function lock - tilted
FUNCTIONS LOCKED - TOO HIGH, 2/2	2/2	Function lock - too high
FUNCTIONS LOCKED - OUTRIGGERS, 2/2	2/2	Function lock - outrigger
FUNCTIONS LOCKED - EXTERNAL SHUTDOWN, 2/2	2/2	Function lock - external shutdown
FUNCTIONS LOCKED - TOO HOT!, 4/2	4/2	Function lock - too hot
DRIVE LOCKED - SEM PROBLEM, A/A	A/A	Drive locked - SEM problem
FAULT: CAN BUS - SEM, 6/6	6/6	Error: Can bus-SEM
FUNCTIONS LOCKED - NO VALVE SUPPLY!, 2/3	2/3	Function lock - no valve supply
FAULT: CHECK ELEVATION SWITCH, 6/3	6/3	Error: Check the lifting switch
FAULT: CHECK HEIGHT1 SENSOR, 6/1	6/1	Error: Check the height switch
CHECK CELL#4 P3B, 6/2	6/2	Check the load cell #4
CHECK CELL#3 P3A, 6/2	6/2	Check the load cell #3
CHECK CELL#2 P2,6/2	6/2	Check the load cell #2
CHECK CELL#1 P1,6/2	6/2	Check the load cell #1
FUNCTIONS LOCKED - NOT CALIBRATED, 1/1	1/1	Function lock - not calibrated
FACTORY OVERRIDE, F/F	F/F	Start safety
CHECK DRIVE / STEER SWITCHES!, 2/2	2/2	Check driving/steering switch
CHECK LIFT SWITCHES!, 2/2	2/2	Check the lifting switch
CHECK JIB SWITCHES!, 2/2	2/2	Check the jib switch
CHECK PLATFORM SWITCHES!, 2/2	2/2	Check platform switch
CHECK TELE SWITCHES!, 2/2	2/2	Check the telescopic switch
CHECK SWING SWITCHES!, 2/2	2/2	Check the swinging switch
FUNCTIONS LOCKED - P600 PROBLEM, 7/7	7/7	Function lock - P600 problem
FAULT: PUMP MOTOR OVERLOAD!,7/7	7/7	Error: Pump motor overload
FAULT: CAPBANK VOLTAGE TOO LOW!,7/7	7/7	Voltage is too low
FAULT: CAPBANK VOLTAGE TOO HIGH!,7/7	7/7	Voltage is too high

FAULT: BATTERY VOLTAGE TOO LOW!, 4/4	4/4	Error: Battery voltage is too low
FAULT: BATTERY VOLTAGE TOO HIGH!, 4/4	4/4	Error: Battery voltage is too high
FAULT: CAN BUS - LOADCELL, 6/6	6/6	Error: Can bus load cell
FAULT: CAN BUS - MATRIX, 6/6	6/6	Error: Can bus matrix
FAULT: CAN BUS - P440, 6/6	6/6	Error: Can bus-P440
FAULT: CAN BUS - P600, 6/6	6/6	Error: Can bus P600
FAULT: ENERGIZED VALVE - CHECK WIRING!, 3/2	3/2	Error: Hydraulic valve - check wiring
FAULT: BAD INTERNAL SAFETY SWITCH!, 3/4	3/4	Error: Bad internal safety switch
FAULT: VALVE FEEDBACK HIGH!, 3/2	3/2	Error: Valve feedback height
FAULT: CUSTOMER, 1/1	1/1	Error: Customer password

## Chapter 6 Pre-Operation Inspection



## 6.1 No Operation Is Allowed

### Unless

You have understood and practiced the principles about safe operation of the vehicle in this manual.

- 1) Avoid dangerous situations.
- 2) Always perform a pre-operation inspection. You should understand pre-operation inspection before proceeding with the next step.
- 3) Check the workplace.
- 4) Always perform a pre-use functional test.
- 5) Use the vehicle only for its intended purpose.

## 6.2 Basic Principles

- 1) It is the operator's responsibility to perform pre-operation inspection and routine maintenance.
- 2) Pre-operation inspection is a very intuitive process that is performed by the operator before each shift. The purpose of the inspection is to determine if there is a significant problem with the vehicle before the operator performs a functional test.
- 3) Pre-operation inspection can also be used to determine if a routine maintenance procedure is necessary. The operator can only perform the routine maintenance items specified in this manual.
- 4) See the checklist on the next page and check each item.
- 5) In the event of any damage or any unauthorized changes different from the normal status, the vehicle should be marked and prohibited from putting into operation.
- 6) Only qualified authorized service technicians are allowed to maintain the vehicle according to the manufacturer's instructions. After the maintenance is completed, the operator must perform a

pre-operation inspection again before continuing the functional test.

- 7) Regular maintenance inspections should be performed by qualified authorized service technicians according to the manufacturer's specifications and the requirements listed in the responsibilities manual.

## 6.3 Pre-Operation Inspection

- 1) Make sure the manual is complete, easy to read, and stored in the manual box on the platform.
- 2) Make sure all decals are clear, legible, and in the right place. See the decal section.
- 3) Check hydraulic oil for leakage and appropriate oil level. Fill the oil as needed. See the "Maintenance" section.
- 4) Check the battery fluid for leakage and appropriate liquid level. Add the distilled water as needed. See the "Maintenance" section.
- 5) Check the following parts or areas for damage, improper installation, parts missing or unauthorized changes:
  - Electrical components, wires and cables
  - Valve block, hose, joint, cylinder
  - Hydraulic tank
  - Drive motor, Swing motor and drive hub
  - Boom wear pad
  - Tires and wheels
  - Limit button switch, tilt sensor and horn
  - Nuts, bolts and other fasteners
  - Platform overload components
  - Platform entrance lifting rod
  - Alarm light
  - Platform control handle
- 6) Check the entire vehicle for the followings:
  - Crack in a weld or structural member
  - Dent or damage to the vehicle
  - Make sure all structural members and other

critical components are complete, and all associated fasteners and pins are in the right position and tightened.

- Make sure the battery is secure and connected properly.
- After completing the inspection, make sure all compartment covers are properly secured and locked.

## 6.4 Checking the Battery

This check should be performed every 250h or quarterly, whichever comes first.

Good battery condition is critical to normal vehicle performance and safe operation. Improper electrolyte levels or damaged cables and wires may result in component damage and dangerous situations.

### Risk of electric shock

**Any live operation can cause serious personal injury or death. Remove all rings, watches and other accessories before operation.**

### Risk of bodily injury

**The battery electrolyte is corrosive. Avoid contact with spilled electrolytes on your hands or other parts of your body for fear of injury. The spilled electrolyte can be neutralized with soda and water.**

### Caution: The following checks

**should be performed after the battery is charged.**

- 1) Wear protective clothing and goggles.
- 2) Make sure the battery cable is securely wired and not corroded.
- 3) Make sure the battery lock lever is secure.
- 4) Remove the battery vent cap.
- 5) Check the battery electrolyte level. If necessary, add the distilled water from the bottom of the battery filler tube. Do not add

excessive distilled water

- 6) Reset the vent cap.

### Caution: Adding terminal

**protectors and anti-corrosion sealants will help eliminate corrosion on battery terminals and cables.**

## 6.5 Checking the Hydraulic

### Oil Level

Maintaining the hydraulic fluid at the proper oil level is essential for the vehicle operation. If the hydraulic oil is at an appropriate oil level, the hydraulic components may be damaged.

Through daily inspections, the inspector can determine changes in the hydraulic oil level which can indicate problems with the hydraulic system.

- 1) Make sure the boom is in the telescoped position and then visually check the hydraulic tank
- 2) Result: The hydraulic oil is above the middle scale of the level gauge and below the maximum scale of the level gauge.
- 3) The hydraulic oil should be filled as needed. No over-filling will be allowed. Hydraulic oil specification.

Use temperature	Oil type	Remark
The lowest temperature > -25 °C	L-HV32 Low temperature hydraulic oil	Chevron
-40 °C < The lowest temperature ≤ -25 °C	L-HS32 Ultra low temperature hydraulic oil	
The lowest temperature ≤ -40 °C	10# Aviation hydraulic oil	

## **Chapter 7 Workplace Inspection**





## 7.1 No Operation Is Allowed

### Unless

You have understood and practiced the principles about safe operation of the vehicle in this manual.

- 1) Avoid dangerous situations.
- 2) Always perform a pre-operation inspection.
- 3) Check the workplace. You should understand pre-operation inspection before proceeding with the next step.
- 4) Always perform a pre-use functional test.
- 5) Use the vehicle only for its intended purpose.

## 7.2 Basic Principles

- 1) Workplace inspection will help the operator determine if the workplace is safe for operation of the vehicle. The operator should perform pre-operation inspection before moving the vehicle to the workplace.
- 2) It is the operator's responsibility to understand and remember the hazards in the workplace and to be aware of and avoid these hazards when moving, installing and operating the vehicle.

## 7.3 Workplace Inspection

Be aware of and avoid the following dangerous situations

- 1) Steep slope or holes
- 2) Protrusions, ground obstacles or debris
- 3) Uneven surface
- 4) Unstable or smooth surface
- 5) Overhead obstacles and high voltage wires
- 6) Dangerous location
- 7) Surface support that is not sufficient to withstand the full load applied by the vehicle
- 8) Wind and weather conditions

- 9) Unauthorized personnel
- 10) Other possible unsafe conditions



## Chapter 8 Functional Test



## 8.1 No Operation Is Allowed Unless

You have understood and practiced the principles about safe operation of the vehicle in this manual.

- 1) Avoid dangerous situations.
- 2) Always perform a pre-operation inspection.
- 3) Check the workplace.
- 4) Always perform a pre-use functional test.
- 5) You should understand the functional test and inspection before proceeding with the next step.
- 6) Use the vehicle only for its intended purpose.

## 8.2 Basic Principles

- 1) Functional tests are used to detect faults before operating the vehicle.
- 2) The operator must follow the steps to test all the functions of the vehicle.
- 3) Do not use a malfunctioning vehicle. If a fault is found, the vehicle must be marked and stopped.
- 4) Only qualified authorized service technicians are allowed to maintain the vehicle according to the manufacturer's instructions.
- 5) After maintenance is completed, the operator must perform the pre-operation inspection and functional test again before operating the vehicle.

## 8.3 Functional Test

- 1) Choose a test place that is solid, level and free of obstacles.
- 2) Make sure the battery has been connected.

## 8.4 Tests from the Lower Control Box

- 1) Turn the key button switch to the position of the lower control box.
- 2) Pull out the red "Emergency Stop" button to the "ON" position.

Result: The alarm light starts to flash.

### Test the Emergency Stop

- 1) Push the ground red "Emergency Stop" button inward to the "OFF" position.

Result: No function can be enabled.

- 2) Pull the red "Emergency Stop" button to the "ON" position.

### Test the Vehicle Function

- 1) Do not press and hold the function enable button switch. Try to enable each boom and platform function button switch.

Result: No boom and platform function can be enabled.

- 2) Press and hold the function enable button and activate each boom and platform function button switch.

Result: The boom and platform functions should operate for a full cycle. When the boom is lowered, the lowering alarm (if equipped) should sound.

### Test the Assist Control

#### (Emergency operation)

- 1) Rotate the key switch toward the ground control unit.
- 2) Pull out the red "Emergency Stop" button to "ON" position.
- 3) Keep the auxiliary power switch on, and activate each boom function button switch.

Note: To save battery power, test each function in a partial cycle.

- 4) Result: All functions should be enabled.

## 8.5 Tests from the Upper Control Box

### Test the Emergency Stop

- 1) Push the platform red "Emergency Stop" button to the "OFF" position.
- 2) Start each function control handle or button switch on the vehicle.

Result: No function can be enabled.

- 3) Pull out the red "Emergency Stop" button to the "ON" position.

### Test the Tilt Sensor

- 1) Turn the key switch toward the upper control box. Pull the platform red "Emergency Stop" button to the "ON" position.
- 2) Press the foot switch.
- 3) Lift the base boom by approximately 0.9m/2.95ft. The vehicle is located at a 3° slope along the boom or 3° in the orthogonal direction of the boom.

Result: The tilt indicator should be always on and the alarm will sound. Limit of extending, lifting and drive functions.

- 4) Lower the base boom to the telescoped position and lift the tower boom by approximately 0.9m/2.95ft. The vehicle is located at a 3° slope along the boom or 3° in the orthogonal direction of the boom.

Result: The tilt indicator should be always on and the alarm will sound. Limit of extending, lifting and drive functions.

- 5) Lower the tower boom to the telescoped position, extend the base boom by approximately 0.6m/1.97ft, and the vehicle is located at a 3° slope along the boom or 3° in the orthogonal direction of the boom.

Result: The tilt indicator should be always on and the alarm will sound. Limit of extending, lifting and drive functions.

- 6) The vehicle is in the telescoped state. The vehicle is located at a 3° slope along the boom or 3° in the orthogonal direction of

the boom.

Result: The tilt indicator may not light and the alarm will sound.

### Test the Horn

- 1) Press the horn button.

Result: The horn will sound.

### Test the Foot Switch

- 1) Do not press the foot switch and test the vehicle's functions.

Result: The vehicle functions cannot be enabled.

### Test the Vehicle Function

- 1) Press the foot switch.
- 2) Start each function control handle or button switch on the vehicle.

Result: All boom/platform functions should work normally in a full cycle.

### Test the Drive and Steering Functions

- 1) Press the foot switch.
- 2) When moving the right control handle upward, the vehicle will drive forward, and when moving the right control handle downward, the vehicle will drive backward.
- 3) When pressing the left side of the thumb rocker, the vehicle will turn to the left, and when pressing the right side of the thumb rocker, the vehicle will turn to the right.

### Test the Drive and Brake Functions

- 1) Press the foot switch.
- 2) Slowly move the right control handle until the vehicle moves forward or backward, and then return the handle to the center position.

Result: The vehicle suddenly stops.



**Caution: The brake must be able to stop the vehicle stably on any slope that it can climb.**

### Test the Drive Enable System

- 1) Press the foot switch and lower the boom to the telescoped position.

- 2) Rotate the turntable until the boom moves more than one non-steering wheel.

Result: The drive enable indicator should be on when the boom is at any position within the range shown in the figure.



- 3) Move the drive control handle away from the center position.

Result: The drive function cannot be enabled.

- 4) Move the drive enable button switch to one side and slowly move the drive control handle away from the center position.

Result: The drive function should be enabled.



**Caution: When operating the**

**drive enable system, the vehicle can drive in the opposite direction of drive and steering control handle movement.**

**Test the limited drive speed**

- 1) Press the foot switch.
- 2) Lift the base boom by approximately 2.95ft.
- 3) Slowly move the drive control handle to the full drive position.

Result: The maximum achievable drive speed may not exceed 0.62mph when the base boom is lifted.

- 4) Lower the base boom to the telescoped state.
- 5) Lift the tower boom by approximately 2.95ft.
- 6) Slowly move the drive control handle to the full drive position.

Result: The maximum achievable drive speed may not exceed 0.62mph when the tower boom is lift.

- 7) Lower the tower boom to the telescoped state.
- 8) Extend the base boom by approximately 0.9m/2.95ft.
- 9) Slowly move the drive control handle to the

full drive position.

Result: The maximum achievable drive speed may not exceed 1km/h/0.62mph when the base boom is extended.

- 10) Telescope the boom.

If the drive speed is above 1km/h/0.62mph when the base boom is lifted and the tower boom is lifted or extended, the vehicle should be marked immediately and stopped.

**Test the Assist Control (Emergency operation)**

- 1) Turn the key button switch to the upper control box.
- 2) Pull the red "Emergency Stop" button to the "ON" position
- 3) Press the foot switch.
- 4) Push the auxiliary power button switch and activate each boom function control handle or button switch.



**Caution: To save battery power,**

**test each function in a partial cycle.**

Result: All boom and steering functions should be enabled. The drive function is limited.

**Test the Lifting/Drive Select Function**

- 1) Press the foot switch.
- 2) Move the drive control handle away from the center position and activate one boom function button switch.

Result: The boom function works normally.





## Chapter 9 Operating Instructions



## 9.1 No Operation Is Allowed Unless

You have understood and practiced the principles about safe operation of the vehicle in this manual.

- 1) Avoid dangerous situations.
- 2) Always perform a pre-operation inspection.
- 3) Check the workplace.
- 4) Always perform a pre-use functional test.
- 5) Use the vehicle only for its intended purpose.

## 9.2 Basic Principles

- 1) The vehicle is a self-propelled electric drive lifting device which is equipped with a working platform on the crank arm mechanism. The vibration generated when the vehicle is running will not be dangerous to the operator who stands on the work platform. The vehicle can be used to load workers and their portable tools to a certain height from the ground, or to reach a certain working area above the vehicle or equipment.
- 2) The Operating Instructions section provides specific instructions for all aspects of vehicle operation. It is the operator's responsibility to follow all safety rules and instructions in this manual.
- 3) This machine is designed for lifting workers and tools to the overhead workplace, it is unsafe or even dangerous to use the vehicle for other purposes.



**Caution: This machine is strictly prohibited from carrying loads.**

- 4) Only trained and authorized personnel can operate the vehicle. If more than one operator uses the same vehicle at different times during the same work shift, they must be qualified operators and follow all safety rules and instructions in the Operation and Maintenance Manual. This means that

every new operator should perform pre-operation inspections, functional tests and workplace inspections before operating the machine.

## 9.3 Emergency Stop

- 1) On the ground control station or platform control station, push the red emergency stop button to the "OFF" position to stop all functions.
- 2) The function should be fixed if it is still working when any of the red emergency stop buttons is pressed.
- 3) Selecting and operating the lower control box will interrupt the function of red "Emergency Stop" button on the platform. The lower control box takes precedence.

## 9.4 Auxiliary Power

If the main power fails, the auxiliary power should be used.

- 1) Turn the key button switch to the ground or the upper control box.
- 2) Pull out the red "Emergency Stop" button to the "ON" position.
- 3) When operating the power unit (i.e., emergency pump) on the platform, press the foot switch.
- 4) Enable the desired function while keeping the power unit (i.e., emergency pump) open.
- 5) The drive function may not work with the power unit.

## 9.5 Operation from the Ground Control Station

- 1) Turn the key switch to the lower control box.
- 2) Pull the red "Emergency Stop" button to the "ON" position.

### Adjust the Platform Position

- 1) Move the function enable button switch to

either side.

- 2) Move the appropriate button switch according to the mark on the control panel.
- 3) The drive and steering functions are not available through the lower control box. The lower control box is not provided with switches for drive and steering.

## 9.6 Operation from the Platform Control Station

- 1) Turn the key button switch to the upper control box position.
- 2) Pull out the red "Emergency Stop" button on the ground and platform to the "ON" position.
- 3) Make sure the battery is connected before operating the vehicle.

### Adjust the platform position

- 1) Press the foot switch.
- 2) Slowly move the corresponding function control handle or button switch according to the mark on the control panel.

### Steer

- 1) Press the foot switch.
- 2) Turn the steering wheel by driving the thumb rocker button on the top of the control handle. When pressing the left button of the thumb rocker, the vehicle will turn to the left; when pressing the right button of the thumb rocker, the vehicle will turn to the right.

### Drive

- 1) Press the foot switch.
- 2) Increase the speed: Slowly move the drive control handle away from the center position.
- 3) Reduce the speed: Slowly move the drive control handle toward the center position.
- 4) Stop: Return the drive control handle to the center position or release the foot switch.
- 5) Determine the direction in which the vehicle will move using the directional arrow on the upper control box.

- 6) The movement speed of the vehicle will be limited when the boom is lifted

 **Warning: Continuous driving may lead to high temperature of the motor or controller. At this time, the controller is under high temperature protection and the driving action is restricted. Put the machine on the ground and wait for the temperature of the motor or controller to decrease before continuing to drive.**

### Drive on a slope

- 1) Determine the rated values of machine on up-slope, down-slope.



Maximum slope rating, platform downhill: 30% (17°)



Maximum slope rating, platform uphill (climbing ability): 25% (14°)



Maximum slope rating: 25% (14°)

 **Warning: When the vehicle is going downhill, select the medium speed mode or the slow speed mode, and that is, set the upper control box button switch in the turtle mode or snail mode!**

 **Caution: The slope rating is limited by the ground conditions and traction.**

Make sure the boom is below the horizontal position and the platform is between the non-steering wheels. Turn the drive speed selector switch to the rabbit position.

- 2) Determine the slope

Measure the slope with a digital inclinometer or follow the steps below.

The following tools are required:

Carpenter's ruler, straight block with a length of at least 1m/3.28ft, tape measure

Place the block on the slope.

Place the carpentry's ruler on the upper edge of the block at the end of the downhill slope and raise the end of the block until it is level.

Keep the block level and measure the vertical distance from the bottom of the block to the ground.

Divide the tape measure distance (the raised height) by the block length (travel) and multiply by 100.

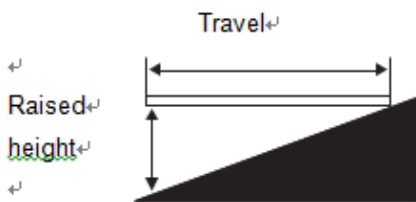

Example:

Wood block = 11.8ft

Travel = 11.8ft

Raised height = 0.98ft

$0.98/11.8 = 8.3\%$  rating

If the slope exceeds the maximum uphill, downhill or side slope rating, the vehicle must be lifted or transported up and down the slope. See the Transportation and Lifting section for further instructions on transporting the machine.

### Drive Enable

- 1) If the indicator is on, it indicates that the boom has moved one of more than two non-steering wheels and the drive function is disabled.
- 2) To drive, move the drive enable button switch to either side and slowly move the drive control handle away from the center position.

Note: The vehicle may move in the opposite direction to the drive and steering control handles.

- 3) Always determine the direction in which the vehicle drives according to the directional arrow on the upper control box.

## 9.7 Platform Overload

### Indicator

The platform overload indicating lamp is ON, and the alarm gives an alarm, indicating the slight overload of platform. Unload the platform until the lamp is OFF before continuing to operate.

When the platform overload alarm, the emergency operation is not limited.

## 9.8 Tilt Indicator

If the tilt alarm sounds while the boom is lowered: Do not extend, rotate or raise the boom above horizontal. Move the machine to a firm, level surface before raising the platform.

If the tilt alarm sounds when the platform is raised: Use extreme caution. Identify the condition of the boom on the slope as shown below. Follow the steps to lower the boom before moving to a firm, level surface. Do not rotate the boom while lowering.

When the vehicle inclines to alarm, the emergency operation is not limited.

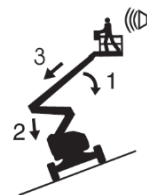

If the tilt alarm sounds on the up-slope of platform:

1. Lower the first boom.
2. Lower the second boom.
3. Retract the first boom.

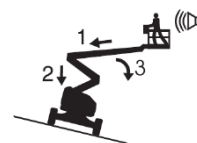

If the tilt alarm sounds on the down-slope of platform:

1. Retract the first boom.

2. Lower the second boom.
3. Lower the first boom.

## 9.9 Fall Protection

### Equipment

Personal Fall Protection Equipment (PFPE) is required to operate the vehicle. All PFPEs must comply with the appropriate government regulations and must be inspected and used according to the manufacturer's instructions.

## 9.10 After Each Use

- 1) Choose a safe parking position, which can be a solid level surface, without obstacles and heavy traffic.
- 2) Telescope and lower the boom to the telescoped state.
- 3) Turn the turntable so that the boom is between the non-steering wheels.
- 4) Turn the key switch to the "OFF" position and remove the key to avoid any unauthorized use.
- 5) Lock the wheel.
- 6) Charge the battery (if necessary).

## 9.11 Instructions for Battery and Charger

- 1) Keep in mind the followings:
  - ① Do not use an external charger or a booster battery.
  - ② Charge the battery in a well-ventilated area.
  - ③ Charge the battery using the correct AC input voltage indicated on the charger.
  - ④ Use only the batteries and chargers approved by LGMG North America, Inc.
- 2) Charge the battery
  - ① Make sure the battery is connected before

charging.

- ② Open the battery compartment cover. The compartment cover should remain open throughout the charging process.
- ③ Remove the battery vent cap and check the battery acid level. If necessary, only add the distilled water necessary for covering the plate. Do not add excessive distilled water before charging.
- ④ Reinstall the battery vent cap.
- ⑤ Connect the battery charger to a grounded AC circuit.
- ⑥ The charger will give an indication when the battery is fully charged. The indicator will flash when not fully charged.

- ⑦ Check the battery acid level at the end of the charge cycle. Add distilled water to be level with the bottom of the filling pipe. Do not add excessive distilled water.

### 3) Instructions for battery filling and charging

- ① Open the battery vent cap.
- ② If the electrolyte level is far above the plate, it indicates that it is unnecessary to add water; if the electrolyte level has not yet come over the plate, it is necessary to add distilled water. Add water to the maximum level.

Do not fill to the maximum level until the battery charging process is completed. Excessive fluid filling may cause the battery acid to overflow during charging. Soda and water can be used to neutralize the spilled battery acid.

- ③ After adding water, reinstall the vent cap on the battery.

- ④ Charge the battery.

- ⑤ Check the battery acid level at the end of the charge cycle. Add distilled water to the bottom of the filling pipe. Do not add excessive distilled water.

## 9.12 Instructions for Skyguard

- 1) The Skyguard protective system aims to

create safe and convenient operating environment for operators on the basis of ensuring operation convenience, the loading capacity of the platform and the operators' field of view.

- 2) The Skyguard protective device is installed above the control panel of the platform. If the safety pole is stressed, the protective system will be activated instantly, and the device will stop all actions immediately, thereby preventing operators from suffering from secondary injury.
- 3) In the extreme case, the safety pole in the protective device will slip to the bottom to ensure operators have sufficient space for buffering and operation. Upon the activation of the Skyguard protective system, the device will give an alarm prompt tone immediately while the blue alarm light flickers. Through the above two approaches, other site operators are reminded, and the safety awareness of neighboring personnel is improved. The Skyguard protective system also provides a safety overriding switch for operators, allowing operators to remove hazards.





## **Chapter 10 Instructions for Transportation and Lifting**



## 10.1 Compliance

- 1) Only personnel with high-altitude lifting qualifications can load and unload the machine.
- 2) The transport vehicle must be parked on a level surface.
- 3) When loading the vehicle, the transport vehicle must be fixed to prevent movement.
- 4) Make sure the transport vehicle's capacity, loading surface, chains or belts are sufficient to withstand the weight of the vehicle. Refer to the nameplate for the weight of the vehicle.
- 5) Make sure the turntable has been fixed with the rotation lock before transporting. Make sure to unlock the turntable before operation.
- 6) Do not drive the vehicle on a slope that exceeds the vehicle's uphill, downhill or slope rating. Refer to "Drive on the Slope" in the "Operation Instructions" section.
- 7) If the slope of the transport vehicle exceeds the maximum slope rating, the winch must be used to load and unload the vehicle as specified.
- 8) The vehicle is equipped with a sophisticated weighting system. It is forbidden to place heavy goods on the platform, when the vehicle is transporting, otherwise the weighting system may be damaged.

## 10.2 Freewheel Configuration for Trailers

- 1) Wedge the wheel to prevent the vehicle from moving.
- 2) Flip over the drive hub cover to release the non-steering wheel brake.

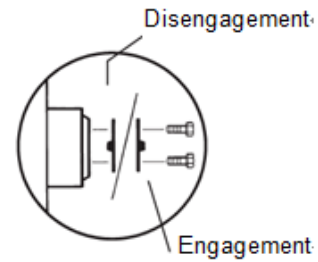

- 3) Make sure that the winch cable is properly secured to the fastening point of the drive chassis and that there are no obstacles in the moving direction.

After the vehicle is loaded:

- ① Wedge the wheel to prevent the vehicle from moving.
- ② Flip over the drive hub cover to engage the non-steering wheel brake.



**Caution: Do not tow the vehicle. If the vehicle must be towed, the speed may not exceed 4.8km/h/3mph.**

## 10.3 Transportation Safety

- 1) The vehicle wheels must always be locked when preparing for transport.
- 2) Before transporting, turn the key switch to the "OFF" position and remove the key.
- 3) Thoroughly inspect the vehicle to prevent loose or unsecured parts.
- 4) Secure the vehicle to the transport surface with the fastening points on the chassis.
- 5) Use at least four chains or belts.

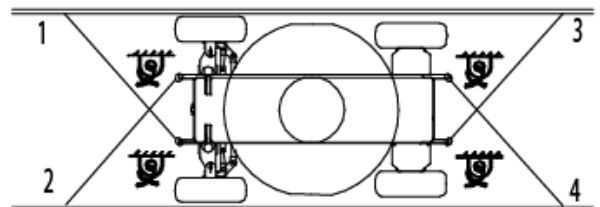

- 6) Make sure the chain or belt used has sufficient load strength.
- 7) Adjust the sling to prevent damage to the chain.
- 8) Make sure that the jib and platform are telescoped. Protect the platform with the

nylon strap on the platform base near the platform rotator (as shown below). Do not apply excessive downward force when protecting the boom components.

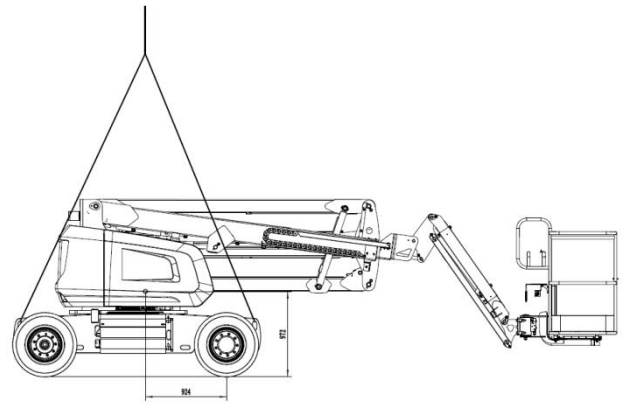
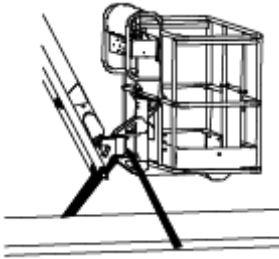

## 10.4 Lifting instructions

### Keep in mind the following:

- 1) Only qualified rigging personnel can assemble the sling and lift the vehicle.
- 2) Make sure that the crane's lifting capacity, loading surface, belt or rope is sufficient to withstand the weight of the vehicle. Refer to the decal and nameplate for the weight of the vehicle.

### Lifting instructions

- 1) Lower and retract the boom completely. Lower the jib boom completely. Remove any loose parts from the vehicle.
- 2) Determine the center of gravity of the vehicle with the help of the picture below.
- 3) Only connect the lifting sling to the specified lifting point on the vehicle. There are four lifting points on the chassis.
- 4) Adjust the sling to avoid any damage to the vehicle and keep the vehicle in a level position.

Model	X	Y
A45JE	38.2in	42.1in

California Proposition 65

 **WARNING**

Operating, servicing and maintaining this equipment can expose you to chemicals including engine exhaust, carbon monoxide, phthalates, and lead, which are known to the State of California to cause cancer and birth defects or other reproductive harm. These chemicals can be emitted from or contained in other various parts and systems, fluids and some component wear by-products. To minimize exposure, avoid breathing exhaust, do not idle the engine except as necessary, service your equipment and vehicle in a well-ventilated area and wear gloves or wash your hands frequently when servicing your equipment or vehicle and after operation. For more information go to [www.P65Warnings.ca.gov/passenger-vehicle](http://www.P65Warnings.ca.gov/passenger-vehicle).

Breathing diesel engine exhaust exposes you to chemicals known to the State of California to cause cancer and birth defects or other reproductive harm.

- Always start and operate the engine in a well-ventilated area.
  - If in an enclosed area, vent the exhaust to the outside.
  - Do not modify or tamper with the exhaust system.
  - Do not idle the engine except as necessary.
- For more information go to [www.P65warnings.ca.gov/diesel](http://www.P65warnings.ca.gov/diesel).

A45JE

Articulated Boom Mobile Elevating Work Platform  
Operation and Safety Manual

Fifth Edition –August 2022



---

1445 Sheffler Drive  
Chambersburg, PA. 17201  
Toll Free: 833.288.LGMG (5464)  
Local Phone: 717.889.LGMG (5464)  
Email: sales@lmgna.com

[www.lmgna.com](http://www.lmgna.com)