



## Service Manual

---

---

S1932 II/S1932E II/S2632 II/S2632E II  
S2646 II/S2646E II /S3246 II/S3246E II  
S4046 II/S4046E II/ S4650 II/S4650E II

## Scissors Mobile Elevating Work Platform

<b>⚠ WARNING</b>
Operators and maintenance personnel must read and understand this manual before operating and maintaining this machine, otherwise it may lead to casualties! This manual shall be properly kept for reference and check by relevant personnel.

LINGONG HEAVY MACHINERY CO., LTD.

# Scissors Mobile Elevating Work Platform

## Service manual

880\*1230 mm Sextodecimo 8 sheets

First edition, April 2022 First print, April 2022

---

LINGONG HEAVY MACHINERY CO., LTD.

Add.: 12F, Building 3, Lushang Olympic City, No. 9777, Jingshi Road, Lixia District, Jinan  
City, Shandong Province, China

Tel: 86-0531-67605017

Technical service: 86-4009666569

Web: [www.LGMG.com.cn](http://www.LGMG.com.cn)

Sales of accessories: 86-0531-67605016

# Contents

Foreword .....	VIII
Safety Notices.....	IX
Chapter 1 Safety and Environment .....	1
1.1 Terms and Definitions.....	3
1.2 Compliance .....	3
1.3 Before maintenance .....	3
1.4 Workplace requirements.....	3
1.5 Safety precautions for maintenance and repair.....	3
1.6 Intended use.....	4
1.7 Description.....	4
Chapter 2 Product Introduction .....	7
2.1 Machine parameters .....	9
2.1.1 S1932 II (S193202WDQ0AH1000) machine parameters .....	9
2.1.2 S1932E II (S193202WDQ0AE1000)machine parameters .....	10
2.1.3 S2632 II (S263202WDQ0AH1000)machine parameters.....	11
2.1.4 S2632E II (S263202WDQ0AE1000)machine parameters .....	12
2.1.5 S2646 II (S264602WDQ0AH1000)machine parameters.....	14
2.1.6 S2646E II (S264602WDQ0AE1000)machine parameters .....	15
2.1.7 S3246 II (S324602WDQ0AH1000)machine parameters.....	16
2.1.8 S3246E II (S324602WDQ0AE1000)machine parameters .....	17
2.1.9 S4046 II (S404602WDQ0AH1000)machine parameters.....	19
2.1.10 S4046E II (S404602WDQ0AE1000)machine parameters .....	20
2.1.11 S4650 II (S465002WDQ0AH1000)machine parameters.....	21
2.1.12 S4650E II (S465002WDQ0AE1000)machine parameters .....	22
2.2 Specification for selection of tightening torque of the lifting platform .....	23
2.3 Key component moment table.....	26
Chapter 3 Platform .....	27
3.1 Removal and installation of PCU .....	29
3.1.1 Removal of PCU .....	29
3.1.2 Installation of PCU .....	29
3.2 Removal and installation of platform assembly.....	29
3.2.1 Removal of platform assembly (S1932 II , S1932E II ).....	29
3.2.2 Installation of platform assembly (S1932 II, S1932 E II).....	30
3.2.3 Removal of platform assembly (S2632 II , S2632E II , S46 II , S46E II , S4650 II , S4650E II ).....	32

---

3.2.4 Installation of platform assembly (S2632 II, S2632 E II, S46 II, S46 E II, S4650 II, S4650 E II).....	33
3.2.5 Folding of platform guardrail.....	34
3.3 Removal and installation of pedal.....	39
3.3.1 Removal of pedal.....	39
3.3.2 Installation of pedal.....	39
3.4 Removal and installation of wheel frame and wheels.....	40
3.4.1 Removal of wheel frames and wheels.....	40
3.4.2 Installation of wheel frames and wheels.....	40
3.5 Removal and installation of semi-swing gate.....	42
3.5.1 Removal of semi-swing gate.....	42
3.5.2 Installation of the semi-swing gate.....	42
Chapter 4 Fork.....	45
4.1 Removal of fourth fork (S1932 II, S1932E II, S2632 II, S2632E II, S2646 II, S2646E II).....	47
4.2 Fourth layer fork assembly (S1932II, S1932EII, S2632II, S2632EII, S2646II, S2646EII).....	53
4.3 Removal of fifth layer fork (S3246 II, S3246 II).....	64
4.4 Installation of fifth layer fork (S3246 II, S3246E II).....	71
4.5 Removal of six-layer fork (S4046 II, S4046E II, S4650 II, S4650E II).....	88
4.6 Installation of sixth layer fork (S4046 II, S4046 E II, S4650 II, S4650 E II).....	92
4.7 Fork slider replacement.....	106
Chapter 5 Chassis.....	107
5.1 Battery Side Assembly.....	109
5.1.1 Left Lock Assembly.....	109
5.1.2 Assembly of S1932E II horn and buzzer.....	109
5.1.3 Assembly of S2632 II, S2632E II, S46 II, S46E II horns and buzzers.....	109
5.1.4 Assembly of S4650 II and S4650E II horns and buzzers.....	110
5.1.5 Assembly of fuse holder and DC power switch.....	110
5.1.7 S1932 II, S1932E II battery assembly.....	110
5.1.8 Assembly of S2632 II, S2632E II, S46 II, S46E II, S4650 II and S4650E II batteries.....	111
5.2 Fuel tank side assembly.....	111
5.2.1 Motor and pump assembly.....	111
5.2.2 Assembly of power unit.....	112
5.2.3 Assembly of electrical control unit.....	112
5.2.4 Filter assembly.....	113
5.2.5 Platform control panel assembly.....	113
5.2.6 Assembly of MCU.....	113
5.3 Chassis Components.....	114
5.3.1 Assembly of Work Indicator Lamp.....	114

---

5.3.2 Assembly of inclination switch .....	114
5.3.3 Assembly of Upper and Lower Limit Switches .....	114
5.3.4 Assembly of pit travel switch.....	115
5.3.5 Assembly of Shaft Fixing Module .....	115
5.3.6 Assembling of gas spring, connecting rod and welded connecting rod assembly .....	115
5.3.7 Wheel Assembly (S1932 II, S1932E II) .....	116
5.3.8 Wheel assembly (S2632 II, S2632E II, S46 II, S46E II, S4650 II, S4650E II) .....	116
Chapter 6 Hydraulics .....	119
6.1 Hydraulic schematic diagram .....	121
6.1.1 Hydraulic schematic diagram of S1932II .....	121
6.1.2 Hydraulic schematic diagram of S1932E II .....	122
6.1.3 Hydraulic schematic diagram of S2632 II .....	123
6.1.4 Hydraulic schematic diagram of S2632E II .....	124
6.1.5 Hydraulic schematic diagram of S2646 II .....	125
6.1.6 Hydraulic schematic diagram of S2646E II .....	126
6.1.7 Hydraulic schematic diagram of S3246 and S4046 II .....	127
6.1.8 Hydraulic schematic diagram of S3246E II , S4046E II and S4650E II .....	128
6.1.9 Hydraulic schematic diagram of S4650 II .....	129
6.2 Valve .....	130
6.2.1 Installing the spool .....	130
6.2.2 Power unit FC-420-1 (S1932E II).....	130
6.2.3 Scissor lift platform control valve ST5188-AE0A (S1932II, S2632II) .....	131
6.2.4 Scissor lift platform control valve ST6158-AE00 (S2632 E II , S46E II , S4650E II ) .....	132
6.2.5 Scissor lift platform control valve ST6887-AE00 (S2646 II , S46 II , S4650 II ).....	133
6.2.6 Lower cylinder valve block assembly ST5006-AC00 (S1932 II, S1932E II, S2632 II, S2632E II) .....	135
6.2.7 Lower lift cylinder valve block assembly ST4846-AC0A (S46II, S46EII, S4650II, S4650EII) .....	136
6.2.8 Upper cylinder valve block assembly ST4960-AC0B (S4046E II , S4046E II ) .....	137
6.2.9 upper cylinder valve block assembly ST4960-AC00 (S4650 II , S4650 E II ).....	138
6.2.10 Testing solenoid valve coil.....	138
6.3 Lift cylinder disassembly and assembly.....	139
6.3.1 Lift cylinder removal .....	139
6.3.2 Assembly of lift cylinder .....	141
6.4 Traveling hydraulic assembly.....	142
6.4.1 Removal of steering cylinder .....	142
6.4.2 Removal of Steering Knuckle .....	143
6.4.3 Disassembly and assembly of walking motor/drive motor .....	143
6.4.4 Disassembly and Assembly of Gear Pump.....	145

---

6.4.5 6.4.5 Removal and installation of hydraulic tank .....	146
6.5 Service brake assembly .....	148
6.5.1 r Removal of brake disc (hydraulic drive) .....	148
6.5.2 Assembly of brake discs (hydraulic drive) .....	149
6.5.3 Assembly of Brake Release Valve (hydraulic drive).....	150
Chapter 7 Electrics.....	151
7.1 Precautions for work of electrical system .....	153
7.2 Schematic Diagram of Location of Main Electrical Appliances .....	153
7.3 Electrical schematic diagram .....	155
7.3.1 Electrical schematic diagram (electric drive).....	155
7.3.2 Electrical schematic diagram (hydraulic drive).....	156
7.4 Main electrical components .....	157
7.4.1 Platform control unit (PCU) .....	157
7.4.2 Platform control unit (PCU) .....	157
7.4.3 Electrical control unit (ECU).....	158
7.4.4 Electronic control unit (ECU) .....	158
7.4.5 Battery .....	160
7.5 Harness .....	163
7.5.1 Table of S1932E II main harness wiring diagram and wire number.....	163
7.5.2 S2632E II , S46EII Main harness wiring diagram and wire size table.....	165
7.5.3 S4650E II Main harness wiring diagram and wire size table .....	167
7.5.4 S1932 II Main harness wiring diagram and wire size table .....	169
7.5.5 S2632 II , S46 II Main harness wiring diagram and wire size table .....	171
7.5.6 S4650 II Main harness wiring diagram and wire size table .....	173
7.5.7 S1932 II and S1932E II PCU harness and fork harness.....	175
7.5.8 S2632 II , S2632E II PCU harness and fork harness .....	176
7.5.9 S2646 II , S2646 E II PCU harness and fork harness .....	177
7.5.10 S3246 II , S3246E II PCU harness and fork harness .....	178
7.5.11S4046 II and S4046E II PCU harness and fork harness .....	179
7.5.12S4650 II and S4650E II PCU harness and fork harness .....	180
7.5.13 Troubleshooting of Electrical Wiring .....	181
7.6 Error code (alarm code).....	182
7.6.1 Alarm code table .....	182
7.6.2 Operation flow diagram .....	186
Chapter 8 Maintenance of Complete Machine.....	187
8.1 Checking the battery .....	189
8.2 Check the hydraulic oil .....	189

---

8.3 check the wire .....	191
8.4 check tire and hub .....	191
8.5 Checking ventilation system of the hydraulic tank cover.....	192
8.6 Inspect the chassis tray lock .....	192
8.7 Inspection of Steering Knuckle .....	192
8.8 Replace the hydraulic tank vent cap .....	193
8.9 Checking wear-resistant slider of scissor arm .....	193
8.10 Inspection and replacement of brushes.....	193
8.11 Replacing hydraulic tank return filter element .....	194
8.12 Maintenance Items.....	196
Chapter 9 Debugging of the Whole Machine .....	201
9.1 Basic function check .....	203
9.2 Hidden danger point inspection .....	203
9.3 Testing key switch.....	204
9.4 Horn Test .....	205
9.5 Test Inclination switch .....	205
9.6 Testing emergency stop function .....	205
9.7 Testing drive speed.....	206
9.8 Testing the function of drive brake .....	206
9.9 Testing limit switch and pothole protection switch .....	206
9.10 Testing platform overload system .....	209
9.11 Test emergency lowering cable.....	210
9.12 Test of battery charging.....	210
9.13 Pressure parameter test.....	211
9.14 Manual release valve function test (hydraulic drive) .....	212
9.15 One-button brake release function test (electric drive) .....	212
9.16 Horizon sensor left and right inclination test.....	213
9.17 Weighing calibration.....	213
9.18 Overload calibration .....	213
Chapter 10 Appendix.....	215
10.1 Schematic diagram of symbols of common hydraulic components .....	217
10.2 Schematic diagram of common electrical component symbols.....	225
10.3 Pipeline Connection Table .....	228
10.3.1 S1932 II Pipeline Connection Table .....	228
10.3.2 S1932E II pipeline connection table .....	229
10.3.3 S2632 II pipeline wiring table .....	229
10.3.4 S2632 E II pipeline wiring table .....	230

10.3.5 S2646 II pipeline wiring table .....	231
10.3.6 S2646 E II Pipeline wiring table .....	232
10.3.7 S3246 II Pipeline wiring table .....	232
10.3.8 S3246E II Pipeline Wiring Table .....	234
10.3.9 S4046 II Pipeline wiring table .....	234
10.3.10 S4046E II Pipeline Wiring Table .....	236
10.3.11 S4650 II Pipeline Wiring Table .....	236
10.3.12 S4650E II Pipeline Wiring Table .....	238



# Foreword

You are welcome to purchase and use the products produced by Lingong Heavy Machinery Co., Ltd. This manual introduces the technical parameter and maintenance adjustment data of the Scissors Mobile Elevating Work Platform, and explains the troubleshooting and maintenance process for qualified professional maintenance personnel. The information contained in this manual are correct at the time of publication, but due to the continuous improvement of the structure and performance of our products, the design as well as operation and maintenance instructions of the product may be subject to change without notice. For the latest information about the machine and questions about this manual, please contact our company. At the same time, we encourage readers to feedback errors to Lingong Heavy Machinery Co., Ltd. and put forward suggestions for improvement. All suggestions will be carefully considered in the future publication and printing of this manual.

The copyright of this manual belongs to Lingong Heavy Machinery Co., Ltd., and it is not allowed to be copied or reprinted without the written permission of our company.

## WARNING

- Only specially trained and qualified personnel can operate, repair and maintain the machine.
- Incorrect operation, maintenance and repair are dangerous and can lead to personal injury or death.
- Before operating or maintaining the machine, the operator should read this manual carefully. Do not operate, maintain or repair this platform without reading and understanding this manual.
- Please load the machine in strict accordance with the rating, otherwise all the consequences arising from overloading or unauthorized modification will be borne by the user.
- The operating procedures and precautions provided in this manual are only applicable to the specified purposes of this machine. If it is used for operations other than those specified but not prohibited, make sure that this operation does not cause harm to you or others.

# Safety Notices

The operator should understand and follow the current national and local safety regulations. If there are no national or local regulations, the safety instructions in this manual shall be applicable.

Most accidents are caused by failure to comply with the regulations on the operation and maintenance of the machine. In order to avoid accidents, please read, understand and observe all warning requirements and precautions in this manual and on the machine before operation and maintenance. Failure to comply with the instructions and safety rules in this manual and the corresponding manual on the machine will result in death or serious injury.

Since it is impossible to foresee all possible dangers, the safety instructions in this manual and on the machine cannot include all safety precautions. If steps and operations not recommended in this manual are used, you must ensure that you and other people are safe and the machine will not be damaged. If you are not sure about the safety of some operations, please contact our company or dealer.

Some operations to the machine require not only basic mechanical, hydraulic and electrical skills, but also professional skills, tools, lifting equipment and suitable workshop. In these cases, we strongly recommend that the maintenance and repair should be carried out at a service center authorized by Lingong Heavy Machinery Co., Ltd.

The maintenance precautions given in this manual are only applicable when the machine is used for the specified purpose. If the machine is used in the scope out of this manual, our company will not assume any safety responsibility, and the safety responsibility in such operations shall be borne by the user and the operator. Under no circumstances shall the operations prohibited in this manual be performed.

Most of the maintenance process can only be performed by trained professional service personnel in properly equipped workshops.

 **DANGER** - Indicating any existing dangers that, if not avoided, will cause serious injury or even death, and also serious machine damage.

 **WARNING** - Indicating any potential dangers that, if not avoided, may cause death or serious injury, and also serious machine damage.

 **CAUTION** - Indicating situations that, if not avoided, may cause minor or moderate injury, and also machine damage or shortened machine service life.

# Chapter 1 Safety and Environment



## 1.1 Terms and Definitions

**Administrator:** the entity or individual that directly controls the use and application of the lifting platform, which usually refers to the owner, the renter or the authorized personnel of owner who obtains the control right of the lifting platform;

**Operator:** personnel who has been professionally trained and mastered qualified knowledge and practical experience to operate the lifting platform.

**Qualified personnel:** those with recognized academic qualifications, certificates, professional status, or relevant professional knowledge, trained and experienced, who can effectively prove their ability to solve the difficulties encountered in related matters, work or projects.

**Safety notice:** relevant safety information issued by Lingong Heavy Machinery Co., Ltd.

## 1.2 Compliance

1. The maintenance is required to be carried out by personnel who have received and qualified in the maintenance training of this machine.
2. Immediately mark the machine if it is damaged or faulty, and withdraw it out of service.
3. Repair any damage or fault before operating the machine.

## 1.3 Before maintenance

1. Read and follow the safety rules and maintenance instructions in the corresponding operation manuals on the machine.
2. Ensure that all necessary tools and parts are in place.
3. Do not use parts not sold by Lingong Group Jinan Heavy Machinery Co., Ltd.
4. Please read each step thoroughly and follow the instructions, and do not try to perform repair by shortcut, as this is dangerous.

## 1.4 Workplace requirements

Unless specially specified, the machine shall be able to operate safely under the following conditions:

1. Altitude  $\leq 1000\text{m}/3281\text{ft}$ ;
2. Ambient humidity  $\leq 90\%$  (at  $+25^{\circ}\text{C}$ ).
3. The machine shall be able to operate normally under the following safe conditions:
  - Ambient temperature of  $-20^{\circ}\text{C} \sim +40^{\circ}\text{C}$ ;
  - Wind speed:  $\leq 12.5\text{m/s}/28\text{mph}$ .
4. During normal operation or maintenance, please set up protective devices as the movement of mechanism and parts may cause danger to human body.
5. Take measures to prevent the danger caused by parts falling from the platform.

## 1.5 Safety precautions for maintenance and repair

1. Before adjusting and repairing the machine, the following preventive measures shall be taken
  - Park the machine on a solid and level ground
  - Block the wheels
  - Cut off the power supply to disable the machine;
  - Set all controls in “OFF” position to prevent the operating system from being started by

accident;

- If possible, lower the platform to the lowest position, otherwise, ensure that it will not fall;
- Before loosening or removing hydraulic components, release the hydraulic oil pressure in the hydraulic pipeline;
- Place safety supports as required.

## 2. Maintenance personnel training

Maintenance personnel must be trained by qualified personnel to inspect and maintain the machine in accordance with the requirements of this manual.

## 3. Parts replacement

The replacement components and parts must be the original parts of our company, otherwise the product will not be maintained or repaired.

## 4. Service announcement

Users shall maintain and repair the machine in strict accordance with the service announcement issued by Lingong Heavy Machinery Co., Ltd.

## 1.6 Intended use

This machine is only intended for lifting people and their tools and materials to a high-altitude workplace.

## 1.7 Description

Most maintenance processes can only be performed by professionally trained maintenance personnel in a properly equipped workshop. After troubleshooting, select the appropriate maintenance steps.

Perform the disassembly steps until the repair can be completed. Then perform the disassembly steps in the reverse order.

It is strongly recommended to carry out maintenance and repair at the service center authorized by Lingong Heavy Machinery Co., Ltd.

Symbol representation

Symbols, color codes and symbolic words used by LGMG products have the following meanings:

Safety warning sign - used for warning of potential personal injury. Observe all safety tips after this sign to avoid possible personal injury or death.



Red - Indicating a hazardous situation. If it is not avoided, it will lead to death or serious injury of personnel.



Orange - Indicating a hazardous situation. If it is not avoided, it may cause death or serious injury.



Yellow - Indicating a dangerous situation. If not avoided, it may cause minor or moderate personal injury.

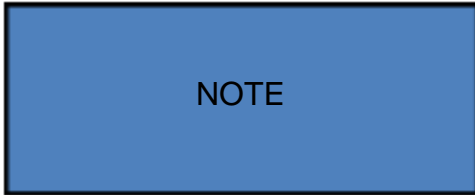

Blue - Indicating a dangerous situation. If not avoided, it may result in property damage.





## Chapter 2 Product Introduction



## 2.1 Machine parameters

### 2.1.1 S1932 II (S193202WDQ0AH1000) machine parameters

#### 1. Machine performance parameters

Item	Parameter	Item	Parameter	
Rated load (kg/lbs)	230/510	Fork lifting time (s)	16±2	
Extension platform load (kg/lbs)	120/265	Fork lowering time (s)	28±3	
Total weight (kg/lbs)	1610/3549	Max. operation effort	Indoor (N)	400
Max. allowed workers (indoor)	2		Outdoor (N)	200
Max. allowed workers (outdoor)	1	Theoretical gradeability (no-load, stowed)	max. (no-load, stowed)	25%
Max. working height (m/ft)	7.8/25.6	Max. allowed inclination	X-direction: left/right	1.5°
Max. platform height (m/ft)	5.8/19		Y-direction: front/rear	3°
Min. turning radius (m/ft)	1.7/5.57	Max. inner wheel turning angle		70°
Max. travel speed (stowed)(km/h/mph)	3±0.5/1.86±0.31	Max. allowed wind speed (m/s/mph)		12.5/28
Max. travel speed (lifted) (km/h/mph)	0.8±0.1/0.5±0.06	Drive mode	Front wheel drive Front wheel steering	
Max. braking distance (no-load, stowed) (mm/in)	600/23.6			

#### 2. Main dimensions

Item	Parameter	Item	Parameter
Overall length (with ladder unfolded /folded) (mm/in)	1860/73.2; 1772/69.7	Platform extension dimension (mm/in)	900/35.4
Overall length (without ladder)(mm/in)	1679/66.1	Wheelbase (mm/in)	1350/53.1
Overall width (mm/in)	790/31.1	Wheel track (mm/in)	700/27.5
Overall height (guardrail unfolded)(mm/in)	2155/84.8	Min. ground clearance (stowed)(mm/in)	77/3.03
Overall height (guardrail folded)(mm/in)	1810/71.2	Min. ground clearance (lifted) (mm/in)	26/1
Working platform dimension (LxW)(mm/in)	1635×730/64.3×28.7	Tire specification (diameter x width) (mm/in)	Φ323×100/12.7×3.9

#### 3. Hydraulic system

Item		Parameter	
Functional system	Type	Open	
	Pump displacement (ml/r)		4
	Walking system	Max. working pressure (MPa/psi)	25/3625
		Motor displacement (ml/r)	260
	Max. working pressure of lifting system (MPa/psi)		19/2756
	Max. working pressure of steering system (MPa/psi)		12/1740
Max. working pressure of brake system (MPa/psi)		25/3625	

#### 4. Electrical system

Item		Parameter
Lifting motor	Rated voltage (V)	24
	Rated current (A)	180
	Rated power (kW)	3.3
	Rated speed (r/min)	3040

Battery	Output voltage (V)	6 (single piece)
	Capacity (Ah)	225 (20-hours discharge rate)
Charger	Nominal AC input voltage (V)	100-240AC
	Maximum AC input current (A)	8.5
	Nominal DC output voltage (V)	24
	Maximum DC output current (A)	30
Control system	Voltage (V)	24

5. Oil filling amount

Item	Parameter	Item	Parameter
Hydraulic oil (L)	9.5		

2.1.2 S1932E II (S193202WDQ0AE1000) machine parameters

1. Machine performance parameters

Item	Parameter	Item	Parameter
Rated load (kg/lbs)	230/510	Fork lifting time (s)	16±2
Extension platform load (kg/lbs)	120/265	Fork lowering time (s)	28±3
Total weight (kg/lbs)	1610/3549	Max. operation effort	Indoor (N) 400
Max. allowed workers (indoor)	2		Outdoor (N) 200
Max. allowed workers (outdoor)	1	Theoretical gradeability (no-load, stowed)	max. 25%
Max. working height (m/ft)	7.8/25.6	Max. allowed inclination	X-direction: left/right 1.5°
Max. platform height (m/ft)	5.8/19		Y-direction: front/rear 3°
Min. turning radius (m/ft)	1.8/5.9	Max. inner wheel turning angle	70°
Max. travel speed (stowed)(km/h/mpH)	3.5±0.2/2.2±0.12	Max. allowed wind speed (m/s/mpH)	12.5/28
Max. travel speed (lifted)(km/h/mpH)	0.8±0.1/0.5±0.06	Drive mode	Front wheel drive Front wheel steering
Max. braking distance (no-load, stowed) (mm/in)	600/23.6		

2. Main dimensions

Item	Parameter	Item	Parameter
Overall length (with ladder unfolded /folded) (mm/in)	1860/73.2; 1772/69.7	Platform extension dimension (mm/in)	900/35.4
Overall length (without ladder)(mm/in)	1679/66.1	Wheelbase (mm/in)	1345/52.9
Overall width (mm/in)	790/31.1	Wheel track (mm/in)	700/27.5
Overall height (guardrail unfolded)(mm/in)	2155/84.8	Min. ground clearance (stowed)(mm/in)	77/3.03
Overall height (guardrail folded)(mm/in)	1810/71.2	Min. ground clearance (lifted) (mm/in)	26/1
Working platform dimension (LxW)(mm/in)	1635x730/64.3x28.7	Tire specification (diameter x width) (mm/in)	Φ323x100/12.7x3.9

3. Transmission system

Item	Parameter	
Walking reducer	Rated output torque (Nm)	500
	Gear ratio	45.13: 1

4. Hydraulic system

Item		Parameter
Functional system	Type	Open
	Pump displacement (ml/r)	3.1
	Max. working pressure of lifting system (MPa/psi)	19/2755
	Max. working pressure of steering system (MPa/psi)	12/1740

### 5. Electrical system

Item		Parameter
Drive motor	Rated voltage (VDC)	24
	Rated current (A)	48
	Rated power (kW)	0.81
	Rated speed (r/min)	1917
Lifting motor	Rated voltage (V)	24
	Rated current (A)	170
	Rated power (kW)	2.4
	Rated speed (r/min)	2800
Battery	Output voltage (V)	6 (single piece)
	Capacity (Ah)	225 (20-hours discharge rate)
Charger	Nominal AC input voltage (V)	100-240VAC
	Maximum AC input current (A)	8.5
	Nominal DC output voltage (V)	24
	Maximum DC output current (A)	30
Control system	Voltage (V)	24

### 6. Oil filling amount

Item	Parameter	Item	Parameter
Hydraulic oil (L)	5	Walking reducer gear oil (L)	0.3

## 2.1.3 S2632 II (S263202WDQ0AH1000) machine parameters

### 1. Machine performance parameters

Item	Parameter	Item	Parameter	
Rated load (kg/lbs)	230/510	Fork lifting time (s)	31±3	
Extension platform load (kg/lbs)	120/265	Fork lowering time (s)	40±3	
Total weight (kg/lbs)	2200/4850	Max. operation effort	Indoor (N)	400
Max. allowed workers (indoor)	2		Outdoor (N)	200
Max. allowed workers (outdoor)	1	Theoretical gradeability (stowed)	max. (no-load, stowed)	25%
Max. working height (m/ft)	9.8/32.2 (in) 8/26.2 (out)	Max. allowed inclination	X-direction: left/right	1.5°
Max. platform height (m/ft)	7.8/25.6 (in) 6/19.7 (out)		Y-direction: front/rear	3°
Min. turning radius (m/ft)	2.20/7.2	Max. inner wheel turning angle		75°
Max. travel speed (stowed)(km/h/mph)	3±0.5/1.9±0.3	Max. allowed wind speed (m/s/mph)		12.5/28
Max. travel speed (lifted) (km/h/mph)	0.8±0.1/0.5±0.06	Drive mode		Front wheel drive
Max. braking distance (no-load, stowed) (mm/in)	600/23.6			Front wheel steering

### 2. Main dimensions

Item	Parameter	Item	Parameter
Overall length (with ladder) (mm/in)	2440/96	Platform extension dimension (mm/in)	900/35.4
Overall length (without ladder)(mm/in)	2270/89.4	Wheelbase (mm/in)	1850/73
Overall width (mm/in)	830/32.7	Wheel track (mm/in)	700/27.6
Overall height (guardrail unfolded)(mm/in)	2280/89.8	Min. ground clearance (stowed)(mm/in)	100/3.94
Overall height (guardrail folded)(mm/in)	1900/74.8	Min. ground clearance (lifted) (mm/in)	25/0.98
Working platform dimension (LxW)(mm/in)	2260x790/89x31.1	Tire specification (diameter x width) (mm/in)	Φ380x130/15x5.1

### 3. Hydraulic system

Item		Parameter	
Functional system	Type	Open	
	Pump displacement (ml/r)	4	
	Walking system	Max. working pressure (MPa/psi)	25/3626
		Motor displacement (ml/r)	375
	Max. working pressure of lifting system (MPa/psi)		21/3046
	Max. working pressure of steering system (MPa/psi)		15/2176
	Max. working pressure of brake system (MPa/psi)		25/3626

### 4. Electrical system

Item		Parameter
Lifting motor	Rated voltage (V)	24
	Rated current (A)	180
	Rated power (kW)	3.3
	Rated speed (r/min)	3040
Battery	Output voltage (V)	6 (single piece)
	Capacity (Ah)	225 (20-hours discharge rate)
Charger	Nominal AC input voltage (V)	100-240VAC
	Maximum AC input current (A)	8.5
	Nominal DC output voltage (V)	24
	Maximum DC output current (A)	30
Control system	Voltage (V)	24

### 5. Oil filling amount

Item	Parameter	Item	Parameter
Hydraulic oil (L)	13		

## 2.1.4 S2632E II (S263202WDQ0AE1000) machine parameters

### 1. Machine performance parameters

Item	Parameter	Item	Parameter	
Rated load (kg/lbs)	230/510	Fork lifting time (s)	31±3	
Extension platform load (kg/lbs)	120/265	Fork lowering time (s)	40±3	
Total weight (kg/lbs)	2200/4850	Max. operation effort	Indoor (N)	400
Max. allowed workers (indoor)	2		Outdoor (N)	200
Max. allowed workers (outdoor)	1	Theoretical gradeability (no-load, stowed)	max.	25%
Max. working height (m/ft)	9.8/32.2 (in)	Max. allowed	X-direction: left/right	1.5°
	8/26.2 (out)			

Max. platform height (m/ft)	7.8/25.6 (in) 6/19.7 (out)	inclination	Y-direction: front/rear	3°
Min. turning radius (m/ft)	2.20/7.2	Max. inner wheel turning angle		75°
Max. travel speed (stowed)(km/h/mph)	3.5±0.5/2.2±0.3	Max. allowed wind speed (m/s/mph)		12.5/28
Max. travel speed (lifted) (km/h/mph)	0.8±0.1/0.5±0.06	Drive mode		Front wheel drive Front wheel steering
Max. braking distance (no-load, stowed) (mm/in)	600/23.6			

## 2. Main dimensions

Item	Parameter	Item	Parameter
Overall length (mm/in)	2440/96	Platform extension dimension (mm/in)	900/35.4
Overall length (without ladder)(mm/in)	2270/89.4	Wheelbase (mm/in)	1850/73
Overall width (mm/in)	830/32.7	Wheel track (mm/in)	700/27.6
Overall height (guardrail unfolded)(mm/in)	2280/89.8	Min. ground clearance (stowed)(mm/in)	100/3.94
Overall height (guardrail folded)(mm/in)	1900/74.8	Min. ground clearance (lifted) (mm/in)	20/0.79
Working platform dimension (LxW)(mm/in)	2260x790/89x31.1	Tire specification (diameter x width) (mm/in)	Φ380x130/15x5.1

## 3. Transmission system

Item	Parameter	
Walking reducer	Rated output torque (Nm)	500
	Gear ratio	45.13: 1

## 4. Hydraulic system

Item	Parameter	
Functional system	Type	Open
	Pump displacement (ml/r)	4
	Max. working pressure of lifting system (MPa/psi)	21/3046
	Max. working pressure of steering system (MPa/psi)	15/2176

## 5. Electrical system

Item	Parameter	
Drive motor	Rated voltage (V)	24
	Rated current (A)	48
	Rated power (kW)	0.81
	Rated speed (r/min)	1917
Lifting motor	Rated voltage (V)	24
	Rated current (A)	180
	Rated power (kW)	3.3
	Rated speed (r/min)	3040
Battery	Output voltage (V)	6 (single piece)
	Capacity (Ah)	225 (20-hours discharge rate)
Charger	Nominal AC input voltage (V)	100-240VAC
	Maximum AC input current (A)	8.5
	Nominal DC output voltage (V)	24
	Maximum DC output current (A)	30
Control system	Voltage (V)	24

## 6. Oil filling amount

Item	Parameter	Item	Parameter
Hydraulic oil (L)	13	Walking reducer gear oil (L)	0.3

## 2.1.5 S2646 II (S264602WDQ0AH1000) machine parameters

### 1. Machine performance parameters

Item	Parameter	Item	Parameter
Rated load (kg/lbs)	450/990	Fork lifting time (s)	35±4
Extension platform load (kg/lbs)	120/265	Fork lowering time (s)	40±4
Total weight (kg/lbs)	2395/5280	Max. operation effort	Indoor (N) 400
Max. allowed workers (indoor)	2		Outdoor (N) 200
Max. allowed workers (outdoor)	1	Theoretical max. gradeability (no-load, stowed)	25%
Max. working height (m/ft)	10/32.8	Max. allowed inclination	X-direction: left/right 1.5°
Max. platform height (m/ft)	8/26.2		Y-direction: front/rear 3°
Min. turning radius (m/ft)	2.45/8.04	Max. inner wheel turning angle	78°
Max. travel speed (stowed)(km/h/mpH)	3±0.5/1.86±0.31	Max. allowed wind speed (m/s/mpH)	12.5/28
Max. travel speed (lifted) (km/h/mpH)	0.8±0.1/0.5±0.06	Drive mode	Front wheel drive Front wheel steering
Max. braking distance (no-load, stowed) (mm/in)	600/23.6		

### 2. Main dimensions

Item	Parameter	Item	Parameter
Overall length (with ladder) (mm/in)	2490/98.03	Platform extension dimension (mm/in)	900/35.43
Overall length (without ladder)(mm/in)	2270/89.37	Wheelbase (mm/in)	1850/73
Overall width (mm/in)	1180/46.46	Wheel track (mm/in)	1050/41.34
Overall height (guardrail unfolded)(mm/in)	2360/92.92	Min. ground clearance (stowed)(mm/in)	100/3.94
Overall height (guardrail folded)(mm/in)	1680/66.14	Min. ground clearance (lifted) (mm/in)	20/0.79
Working platform dimension (LxW)(mm/in)	2260×1120/88.98×44.09	Tire specification (diameter x width) (mm/in)	Φ380×130/15×5.1

### 3. Hydraulic system

Item		Parameter	
Functional system	Type	Open	
	Pump displacement (ml/r)	4.5	
	Walking system	Max. working pressure (MPa/psi)	25/3626
		Motor displacement (ml/r)	395
	Max. working pressure of lifting system (MPa/psi)	21/3046	
	Max. working pressure of steering system (MPa/psi)	15/2176	
Max. working pressure of brake system (MPa/psi)	25/3626		

### 4. Electrical system

Item	Parameter	
Lifting motor	Rated voltage (V)	24
	Rated current (A)	235
	Rated power (kW)	4.5
	Rated speed (r/min)	2750
Battery	Output voltage (V)	6 (single piece)



	Capacity (Ah)	240 (20-hour discharge rate)
Charger	Nominal AC input voltage (V)	100-240VAC
	Maximum AC input current (A)	8.5
	Nominal DC output voltage (V)	24
	Maximum DC output current (A)	30
Control system	Voltage (V)	24

5. Oil filling amount

Item	Parameter	Item	Parameter
Hydraulic oil (L)	16		

2.1.6 S2646E II (S264602WDQ0AE1000) machine parameters

1. Machine performance parameters

Item	Parameter	Item	Parameter
Rated load (kg/lbs)	450/990	Fork lifting time (s)	35±4
Extension platform load (kg/lbs)	120/265	Fork lowering time (s)	40±4
Total weight (kg/lbs)	2318/5110	Max. operation effort	Indoor (N) 400
Max. allowed workers (indoor)	2		Outdoor (N) 200
Max. allowed workers (outdoor)	1	Theoretical max. gradeability (no-load, stowed)	25%
Max. working height (m/ft)	10/32.8	Max. allowed inclination	X-direction: left/right 1.5°
Max. platform height (m/ft)	8/26.2		Y-direction: front/rear 3°
Min. turning radius (m/ft)	2.45/8.04	Max. inner wheel turning angle	78°
Max. travel speed (stowed)(km/h/mpH)	3.5±0.2/2.2±0.12	Max. allowed wind speed (m/s/mpH)	12.5/28
Max. travel speed (lifted)(km/h/mpH)	0.8±0.1/0.5±0.06	Drive mode	Front wheel drive Front wheel steering
Max. braking distance (no-load, stowed) (mm/in)	600/23.6		

2. Main dimensions

Item	Parameter	Item	Parameter
Overall length (mm/in)	2490/98.03	Platform extension dimension (mm/in)	900/35.43
Overall length (without ladder)(mm/in)	2270/89.4	Wheelbase (mm/in)	1850/73
Overall width (mm/in)	1180/46.46	Wheel track (mm/in)	1050/41.34
Overall height (guardrail unfolded)(mm/in)	2360/92.92	Min. ground clearance (stowed)(mm/in)	100/3.94
Overall height (guardrail folded)(mm/in)	1550/61.02	Min. ground clearance (lifted) (mm/in)	20/0.79
Working platform dimension (LxW)(mm/in)	2260×1120/88.98×44.09	Tire specification (diameter x width) (mm/in)	Φ380×130/15×5.1

3. Transmission system

Item	Parameter	
Walking reducer	Rated output torque (Nm)	500
	Gear ratio	45.13: 1

4. Hydraulic system

Item	Parameter
------	-----------

Functional system	Type	Open
	Pump displacement (ml/r)	4.5
	Max. working pressure of lifting system (MPa/psi)	21/3046
	Max. working pressure of steering system (MPa/psi)	15/2176

### 5. Electrical system

Item		Parameter
Drive motor	Rated voltage (VDC)	24
	Rated current (A)	48
	Rated power (kW)	0.81
	Rated speed (r/min)	1917
Lifting motor	Rated voltage (V)	24
	Rated current (A)	235
	Rated power (kW)	4.5
	Rated speed (r/min)	2750
Battery	Output voltage (V)	6 (single piece)
	Capacity (Ah)	240 (20-hour discharge rate)
Charger	Nominal AC input voltage (V)	100-240VAC
	Maximum AC input current (A)	8.5
	Nominal DC output voltage (V)	24
	Maximum DC output current (A)	30
Control system	Voltage (V)	24

### 6. Oil filling amount

Item	Parameter	Item	Parameter
Hydraulic oil (L)	16	Walking reducer gear oil (L)	0.3

## 2.1.7 S3246 II (S324602WDQ0AH1000) machine parameters

### 1. Machine performance parameters

Item	Parameter	Item	Parameter	
Rated load (kg/lbs)	320/705	Fork lifting time (s)	58±4	
Extension platform load (kg/lbs)	120/265	Fork lowering time (s)	48±4	
Total weight (kg/lbs)	2995/6603	Max. operation effort	Indoor (N)	400
Max. allowed workers (indoor)	2		Outdoor (N)	200
Max. allowed workers (outdoor)	1	Theoretical gradeability (no-load, stowed)	max. (no-load, stowed)	25%
Max. working height (m/ft)	12/39.4	Max. allowed inclination	X-direction: left/right	1.5°
Max. platform height (m/ft)	10/32.8		Y-direction: front/rear	3°
Min. turning radius (m/ft)	2.45/8.04	Max. inner wheel turning angle		75°
Max. travel speed (stowed)(km/h/mph)	3±0.5/1.86±0.31	Max. allowed wind speed (m/s/mph)		12.5/28
Max. travel speed (lifted) (km/h/mph)	0.8±0.1/0.5±0.06	Drive mode		Front wheel drive Front wheel steering
Max. braking distance (no-load, stowed) (mm/in)	600/23.6			

### 2. Main dimensions

Item	Parameter	Item	Parameter
Overall length (with ladder) (mm/in)	2490/98.03	Platform extension dimension (mm/in)	900/35.43
Overall length (without ladder)(mm/in)	2270/89.37	Wheelbase (mm/in)	1850/73
Overall width (mm/in)	1180/46.46	Wheel track (mm/in)	1050/41.34
Overall height (guardrail unfolded)(mm/in)	2490/98.03	Min. ground clearance (stowed)(mm/in)	100/3.94
Overall height (guardrail folded)(mm/in)	1710/62.32	Min. ground clearance (lifted) (mm/in)	20/0.79
Working platform dimension (LxW)(mm/in)	2260x1120/88.98x44.09	Tire specification (diameter x width) (mm/in)	Φ380x130/15x5.1

### 3. Hydraulic system

Item		Parameter	
Functional system	Type	Open	
	Pump displacement (ml/r)	4.5	
	Walking system	Max. working pressure (MPa/psi)	25/3626
		Motor displacement (ml/r)	395
	Max. working pressure of lifting system (MPa/psi)		21/3046
	Max. working pressure of steering system (MPa/psi)		15/2176
	Max. working pressure of brake system (MPa/psi)		25/3626

### 4. Electrical system

Item		Parameter
Lifting motor	Rated voltage (V)	24
	Rated current (A)	235
	Rated power (kW)	4.5
	Rated speed (r/min)	2750
Battery	Output voltage (V)	6 (single piece)
	Capacity (Ah)	240 (20-hour discharge rate)
Charger	Nominal AC input voltage (V)	100-240VAC
	Maximum AC input current (A)	8.5
	Nominal DC output voltage (V)	24
	Maximum DC output current (A)	30
Control system	Voltage (V)	24

### 5. Oil filling amount

Item	Parameter	Item	Parameter
Hydraulic oil (L)	23		

## 2.1.8 S3246E II (S324602WDQ0AE1000) machine parameters

### 1. Machine performance parameters

Item	Parameter	Item	Parameter	
Rated load (kg/lbs)	320/705	Fork lifting time (s)	58±4	
Extension platform load (kg/lbs)	120/265	Fork lowering time (s)	48±4	
Total weight (kg/lbs)	2995/6603	Max. operation effort	Indoor (N)	400
Max. allowed workers (indoor)	2		Outdoor (N)	200
Max. allowed workers (outdoor)	1	Theoretical gradeability (no-load, stowed)	max. (no-load)	25%
Max. working height (m/ft)	12/39.4	Max. allowed inclination	X-direction: left/right	1.5°
Max. platform height (m/ft)	10/32.8		Y-direction:	3°

		front/rear	
Min. turning radius (m/ft)	2.45/8.04	Max. inner wheel turning angle	75°
Max. travel speed (stowed)(km/h/mpH)	3.5±0.2/2.2±0.12	Max. allowed wind speed (m/s/mpH)	12.5/28
Max. travel speed (lifted) (km/h/mpH)	0.8±0.1/0.5±0.06	Drive mode	Front wheel drive Front wheel steering
Max. braking distance (no-load, stowed) (mm/in)	600/23.6		

## 2. Main dimensions

Item	Parameter	Item	Parameter
Overall length (mm/in)	2490/98.03	Platform extension dimension (mm/in)	900/35.43
Overall length (without ladder)(mm/in)	2270/89.37	Wheelbase (mm/in)	1850/73
Overall width (mm/in)	1180/46.46	Wheel track (mm/in)	1050/41.34
Overall height (guardrail unfolded)(mm/in)	2490/98.03	Min. ground clearance (stowed)(mm/in)	100/3.94
Overall height (guardrail folded)(mm/in)	1675/65.94	Min. ground clearance (lifted) (mm/in)	20/0.79
Working platform dimension (LxW)(mm/in)	2260×1120/88.98×44.09	Tire specification (diameter x width) (mm/in)	Φ380×130/15×5.1

## 3. Transmission system

Item	Parameter	
Walking reducer	Rated output torque (Nm)	500
	Gear ratio	45.13: 1

## 4. Hydraulic system

Item	Parameter	
Functional system	Type	Open
	Pump displacement (ml/r)	4.5
	Max. working pressure of lifting system (MPa/psi)	21/3046
	Max. working pressure of steering system (MPa/psi)	15/2176

## 5. Electrical system

Item	Parameter	
Drive motor	Rated voltage (VDC)	24
	Rated current (A)	48
	Rated power (kW)	0.81
	Rated speed (r/min)	1917
Lifting motor	Rated voltage (V)	24
	Rated current (A)	235
	Rated power (kW)	4.5
	Rated speed (r/min)	2750
Battery	Output voltage (V)	6 (single piece)
	Capacity (Ah)	240 (20-hour discharge rate)
Charger	Nominal AC input voltage (V)	100-240VAC
	Maximum AC input current (A)	8.5
	Nominal DC output voltage (V)	24
	Maximum DC output current (A)	30
Control system	Voltage (V)	24

## 6. Oil filling amount

Item	Parameter	Item	Parameter
Hydraulic oil (L)	23	Walking reducer gear oil (L)	0.3

## 2.1.9 S4046 II (S404602WDQ0AH1000) machine parameters

### 1. Machine performance parameters

Item	Parameter	Item	Parameter	
Rated load (kg/lbs)	320/705	Fork lifting time (s)	65±4	
Extension platform load (kg/lbs)	120/265	Fork lowering time (s)	60±4	
Total weight (kg/lbs)	2970/6548	Max. operation effort	Indoor (N)	400
Max. allowed workers (indoor)	2		Outdoor (N)	200
Max. allowed workers (outdoor)	1	Theoretical gradeability (no-load, stowed)	max. (no-load, stowed)	25%
Max. working height (m/ft)	14/46(in) 9.5/31.17(out)	Max. allowed inclination	X-direction: left/right	1.5°
Max. platform height (m/ft)	12/39.4 (in) 7.5/24.6 (out)		Y-direction: front/rear	3°
Min. turning radius (m/ft)	2.45/8.04	Max. inner wheel turning angle		75°
Max. travel speed (stowed)(km/h/mph)	3±0.5/1.86±0.31	Max. allowed wind speed (m/s/mph)		12.5/28
Max. travel speed (lifted) (km/h/mph)	0.8±0.1/0.5±0.06	Drive mode		Front wheel drive Front wheel steering
Max. braking distance (no-load, stowed) (mm/in)	600/23.6			

### 2. Main dimensions

Item	Parameter	Item	Parameter
Overall length (with ladder) (mm/in)	2490/98.03	Platform extension dimension (mm/in)	900/35.43
Overall length (without ladder)(mm/in)	2270/89.37	Wheelbase (mm/in)	1850/73
Overall width (mm/in)	1180/46.46	Wheel track (mm/in)	1050/41.34
Overall height (guardrail unfolded)(mm/in)	2630/103.54	Min. ground clearance (stowed)(mm/in)	100/3.94
Overall height (guardrail folded)(mm/in)	1840/72.44	Min. ground clearance (lifted) (mm/in)	20/0.79
Working platform dimension (LxW)(mm/in)	2260×1120/88.98×44.09	Tire specification (diameter x width) (mm/in)	Φ380×130/15×5.1

### 3. Hydraulic system

Item		Parameter	
Functional system	Type	Open	
	Pump displacement (ml/r)	4.5	
	Walking system	Max. working pressure (MPa/psi)	25/3626
		Motor displacement (ml/r)	395
	Max. working pressure of lifting system (MPa/psi)		21/3046
	Max. working pressure of steering system (MPa/psi)		15/2176
Max. working pressure of brake system (MPa/psi)		25/3626	

### 4. Electrical system

Item		Parameter
Lifting motor	Rated voltage (V)	24
	Rated current (A)	235
	Rated power (kW)	4.5
	Rated speed (r/min)	2750
Battery	Output voltage (V)	12
	Capacity (Ah)	150 (20-hour discharge rate)

Charger	Nominal AC input voltage (V)	100-240VAC
	Maximum AC input current (A)	8.5
	Nominal DC output voltage (V)	24
	Maximum DC output current (A)	30
Control system	Voltage (V)	24

## 5. Oil filling amount

Item	Parameter	Item	Parameter
Hydraulic oil (L)	23		

## 2.1.10 S4046E II (S404602WDQ0AE1000) machine parameters

### 1. Machine performance parameters

Item	Parameter	Item	Parameter
Rated load (kg/lbs)	320/705	Fork lifting time (s)	65±4
Extension platform load (kg/lbs)	120/265	Fork lowering time (s)	60±4
Total weight (kg/lbs)	2970/6548	Max. operation effort	Indoor (N) 400
Max. allowed workers (indoor)	2		Outdoor (N) 200
Max. allowed workers (outdoor)	1	Theoretical gradeability (no-load, stowed)	max. 25%
Max. working height (m/ft)	14/46(in) 9.5/31.17(out)	Max. allowed inclination	X-direction: left/right 1.5°
Max. platform height (m/ft)	12/39.4 (in) 7.5/24.6 (out)		Y-direction: front/rear 3°
Min. turning radius (m/ft)	2.45/8.04	Max. inner wheel turning angle	75°
Max. travel speed (stowed)(km/h/mph)	3.5±0.2/2.2±0.12	Max. allowed wind speed (m/s/mph)	12.5/28
Max. travel speed (lifted) (km/h/mph)	0.8±0.1/0.5±0.06	Drive mode	Front wheel drive Front wheel steering
Max. braking distance (no-load, stowed) (mm/in)	600/23.6		

### 2. Main dimensions

Item	Parameter	Item	Parameter
Overall length (mm/in)	2490/98.03	Platform extension dimension (mm/in)	900/35.43
Overall length (without ladder)(mm/in)	2270/89.37	Wheelbase (mm/in)	1850/73
Overall width (mm/in)	1180/46.46	Wheel track (mm/in)	1050/41.34
Overall height (guardrail unfolded)(mm/in)	2630/103.54	Min. ground clearance (stowed)(mm/in)	100/3.94
Overall height (guardrail folded)(mm/in)	1800/70.87	Min. ground clearance (lifted) (mm/in)	20/0.79
Working platform dimension (LxW)(mm/in)	2260×1120/88.98×44.09	Tire specification (diameter x width) (mm/in)	Φ380×130/15×5.1

### 3. Transmission system

Item	Parameter	
Walking reducer	Rated output torque (Nm)	500
	Gear ratio	45.13: 1

### 4. Hydraulic system

Item	Parameter	
Functional system	Type	Open
	Pump displacement (ml/r)	4.5
	Max. working pressure of lifting system	21/3046

	(MPa/psi)	
	Max. working pressure of steering system (MPa/psi)	15/2176

5. Electrical system

Item	Parameter	
Drive motor	Rated voltage (VDC)	24
	Rated current (A)	48
	Rated power (kW)	0.81
	Rated speed (r/min)	1917
Lifting motor	Rated voltage (V)	24
	Rated current (A)	235
	Rated power (kW)	4.5
	Rated speed (r/min)	2750
Battery	Output voltage (V)	12
	Capacity (Ah)	150 (20-hour discharge rate)
Charger	Nominal AC input voltage (V)	100-240VAC
	Maximum AC input current (A)	8.5
	Nominal DC output voltage (V)	24
	Maximum DC output current (A)	30
Control system	Voltage (V)	24

6. Oil filling amount

Item	Parameter	Item	Parameter
Hydraulic oil (L)	23	Walking reducer gear oil (L)	0.3

2.1.11 S4650 II (S465002WDQ0AH1000) machine parameters

1. Machine performance parameters

Item	Parameter	Item	Parameter	
Rated load (kg/lbs)	320/705	Fork lifting time (s)	80±4	
Extension platform load (kg/lbs)	120/265	Fork lowering time (s)	65±4	
Total weight (kg/lbs)	3500/7716	Max. operation effort	Indoor (N)	400
Max. allowed workers (indoor)	2		Outdoor (N)	200
Max. allowed workers (outdoor)	1	Theoretical gradeability (no-load, stowed)	max. (no-load, stowed)	25%
Max. working height (m/ft)	15.8/51.8 (in)	Max. allowed inclination	X-direction: left/right	1.5°
	10/32.8 (out)		Y-direction: front/rear	3°
Max. platform height (m/ft)	13.8/45.3 (in)	Max. inner wheel turning angle	Max. allowed wind speed (m/s/mph)	12.5/28
	8/26.2 (out)			
Min. turning radius (m/ft)	2.85/9.35	Drive mode	Front wheel drive Front wheel steering	
Max. travel speed (stowed)(km/h/mph)	3±0.5/1.86±0.31			
Max. travel speed (lifted) (km/h/mph)	0.8±0.1/0.5±0.06			
Max. braking distance (no-load, stowed) (mm/in)	600/23.6			

2. Main dimensions

Item	Parameter	Item	Parameter
Overall length (with ladder) (mm/in)	2800/110.2	Platform extension dimension (mm/in)	900/35.4
Overall length (without ladder)(mm/in)	2650/104.3	Wheelbase (mm/in)	2220/87.4
Overall width (mm/in)	1300/51.2	Wheel track (mm/in)	1175/46.3
Overall height (guardrail unfolded)(mm/in)	2740/107.8	Min. ground clearance (stowed)(mm/in)	105/4.1
Overall height (guardrail folded)(mm/in)	1940/76.4	Min. ground clearance (lifted) (mm/in)	20/0.79
Working platform dimension (LxW)(mm/in)	2640x1120/103.9x44.1	Tire specification (diameter x width) (mm/in)	Φ380x130/15x5.1

### 3. Hydraulic system

Item		Parameter	
Functional system	Type	Open	
	Pump displacement (ml/r)	4.5	
	Walking system	Max. working pressure (MPa/psi)	25/3626
		Motor displacement (ml/r)	395
	Max. working pressure of lifting system (MPa/psi)		21/3046
	Max. working pressure of steering system (MPa/psi)		16.5/2393
	Max. working pressure of brake system (MPa/psi)		25/3626

### 4. Electrical system

Item		Parameter
Lifting motor	Rated voltage (V)	24
	Rated current (A)	235
	Rated power (kW)	4.5
	Rated speed (r/min)	2750
Battery	Output voltage (V)	12
	Capacity (Ah)	150 (20-hour discharge rate)
Charger	Nominal AC input voltage (V)	100-240VAC
	Maximum AC input current (A)	8.5
	Nominal DC output voltage (V)	24
	Maximum DC output current (A)	30
Control system	Voltage (V)	24

### 5. Oil filling amount

Item	Parameter	Item	Parameter
Hydraulic oil (L)	25.5		

## 2.1.12 S4650E II (S465002WDQ0AE1000) machine parameters

### 1. Machine performance parameters

Item	Parameter	Item	Parameter	
Rated load (kg/lbs)	320/705	Fork lifting time (s)	80±4	
Extension platform load (kg/lbs)	120/265	Fork lowering time (s)	65±4	
Total weight (kg/lbs)	3500/7716	Max. operation effort	Indoor (N)	400
Max. allowed workers (indoor)	2		Outdoor (N)	200
Max. allowed workers (outdoor)	1	Theoretical gradeability (no-load, stowed)	max. (no-load)	25%
Max. working height (m/ft)	15.8/51.8 (in)	Max. allowed inclination	X-direction: left/right	1.5°
	10/32.8 (out)		Y-direction:	3°
Max. platform height (m/ft)	13.8/45.3 (in)			



	8/26.2 (out)	front/rear	
Min. turning radius (m/ft)	2.85/9.35	Max. inner wheel turning angle	75°
Max. travel speed (stowed)(km/h/mpH)	3.5±0.2/2±0.12	Max. allowed wind speed (m/s/mpH)	12.5/28
Max. travel speed (lifted) (km/h/mpH)	0.8±0.1/0.5±0.06	Drive mode	Front wheel drive Front wheel steering
Max. braking distance (no-load, stowed) (mm/in)	600/23.6		

## 2. Main dimensions

Item	Parameter	Item	Parameter
Overall length (mm/in)	2800/110.2	Platform extension dimension (mm/in)	900/35.4
Overall length (without ladder)(mm/in)	2650/104.3	Wheelbase (mm/in)	2220/87.4
Overall width (mm/in)	1300/51.2	Wheel track (mm/in)	1175/46.3
Overall height (guardrail unfolded)(mm/in)	2740/107.8	Min. ground clearance (stowed)(mm/in)	105/4.1
Overall height (guardrail folded)(mm/in)	1940/76.4	Min. ground clearance (lifted) (mm/in)	20/0.79
Working platform dimension (LxW)(mm/in)	2640×1120/103.9×44.1	Tire specification (diameter x width) (mm/in)	Φ380×130/15×5.1

## 3. Transmission system

Item	Parameter	
Walking reducer	Rated output torque (Nm)	500
	Gear ratio	45.13: 1

## 4. Hydraulic system

Item	Parameter	
Functional system	Type	Open
	Pump displacement (ml/r)	4.5
	Max. working pressure of lifting system (MPa/psi)	21/3046
	Max. working pressure of steering system (MPa/psi)	16.5/2393

## 5. Electrical system

Item	Parameter	
Drive motor	Rated voltage (VDC)	24
	Rated current (A)	48
	Rated power (kW)	0.81
	Rated speed (r/min)	1917
Lifting motor	Rated voltage (V)	24
	Rated current (A)	235
	Rated power (kW)	4.5
	Rated speed (r/min)	2750
Battery	Output voltage (V)	12
	Capacity (Ah)	150 (20-hour discharge rate)
Charger	Nominal AC input voltage (V)	100-240VAC
	Maximum AC input current (A)	8.5
	Nominal DC output voltage (V)	24
	Maximum DC output current (A)	30
Control system	Voltage (V)	24

## 6. Oil filling amount

Item	Parameter	Item	Parameter
Hydraulic oil (L)	25.5	Walking reducer gear oil (L)	0.3

## 2.2 Specification for selection of tightening torque of the lifting platform

The tightening torque tolerance range is 10% for all hydraulic seals, important transmission connectors and key processes with defined torque tightening requirements, and 20% for non-essential reference torques, which is to be rounded to the nearest integer when necessary.

Table 1: Tightening torque of metric/imperial-threaded fittings and plugs (unit: N.m)

Tightening torque of metric-threaded oil ports					Tightening torque of imperial-threaded oil ports				
Pipe diameter	Thread specification (mm)	Fitting type		Plug VSTI-E	Pipe diameter	Thread specification (Inch)	Fitting type		Plug VSTI-ED
		Type E	Type F				Type E	Type F	
6L	M10X1.0	27	22	16	6L	G1/8A	22	16	16
8L	M12X1.5	37	32	27	8L	G1/4A	37	32	32
10L	M14X1.5	58	48	37	10L	G1/4A	37	32	/
12L	M16X1.5	75	58	58	12L	G3/8A	75	58	63
15L	M18X1.5	95	75	70	15L	G1/2A	120	95	85
18L	M22X1.5	140	115	95	18L	G1/2A	120	95	/
22L	M28X2.0	190	160	140	22L	G3/4A	190	160	140
28L	M33X2.0	325	220	235	28L	G1A	325	220	210
35L	M42X2.0	470	295	380	35L	G11/4A	470	315	470
42L	M48X2.0	565	380	/	42L	G11/4A	565	380	470
6S	M12X1.5	42	37	/	6S	G1/4A	42	37	/
8S	M14X1.5	53	48	/	8S	G1/4A	42	37	/
10S	M16X1.5	75	58	/	10S	G3/8A	85	63	/
12S	M18X1.5	95	75	/	12S	G3/8A	85	63	/
14S	M20X1.5	130	85	/	14S	G1/2A	120	95	/
16S	M22X1.5	140	105	/	16S	G1/2A	120	95	/
20S	M27X2.0	190	180	/	20S	G3/4A	190	160	/
25S	M33X2.0	325	325	/	25S	G1A	325	220	/
30S	M42X2.0	470	345	/	30S	G11/4A	470	315	/
38S	M48X2.0	565	440	/	38S	G11/2A	565	380	/

Table 2: tightening torque of UN-threaded fittings and plugs (unit: N.m)

Product Series	Thread UN/UNF	Non-directional assembly torque N.m	Non-directional assembly torque N.m
EO-L	7/16-20 UN(F)	23	18
	1/2-20 UN(F)	28	28
	9/16-18 UN(F)	34	34
	3/4-16 UN(F)	60	55
	7/8-14 UN(F)	115	80
	1-1/16-12 UN(F)	140	100
	1-5/16-12 UN(F)	210	150
	1-5/8-12 UN(F)	290	290
EO-S	1-7/8-12 UN(F)	325	325
	7/16-20 UN(F)	20	20
	1/2-20 UN(F)	40	40
	9/16-18 UN(F)	46	46
	3/4-16 UN(F)	80	80
	7/8-14 UN(F)	135	135
	1-1/16-12 UN(F)	185	185
	1-5/16-12 UN(F)	270	270
1-5/8-12 UN(F)	340	340	
1-7/8-12 UN(F)	415	415	

Description:

1. Table 1 gives the torques for metric-threaded joints and inch-threaded joints, and Table 2 gives the torques for UN-threaded joints, and for those torques, an error of +10% is allowed;
2. The torque values given in Table 1 and Table 2 are based on the condition that the connected part is made of steel, and for connected part made of aluminum, the tightening torque equal to 60% of the corresponding torque in Table 2 and Table 3 shall apply and shall be rounded to the nearest integer after calculation;

3. For Parker joints, the torque is to be selected according to the name and specification, and for ordinary joints, the torque is to be selected according to the thread specification.

For example:

1) GE 28 L M ED OMD A3C: GE for straight-through joint, 28 for pipe diameter, L for normal pressure, M for metric thread, ED for E-type elastic seal, OMD for no nut sleeve, A3C for galvanizing; According to the 28L M ED, the torque value can be selected from Table 1: 325N.m

2) GE O 22L R 3/4 OMDA3C: O represents the F-type O-ring seal, R represents the inch thread, and 3/4 represents the thread specification G3/4; According to O 22L R3/4, the torque value can be selected from Table 2: 160N.m;

3) GE O 20 S R OMDCF: S represents the heavy pressure, and the torque value selected according to O 20 S R is: 160 N.m;

Table 3: Tightening Torque of Metric-Threaded Swivel Nuts (unit: N.m)

Pipe diameter	Thread specifications	Tightening torque	Pipe diameter	Thread specifications	Tightening torque N•m
06L	M12X1.5	16	06S	M14X1.5	27
08L	M14X1.5	22	08S	M16X1.5	42
10L	M16X1.5	32	10S	M18X1.5	53
12L	M18X1.5	42	12S	M20X1.5	63
15L	M22X1.5	58	14S	M22X1.5	80
18L	M26X1.5	90	16S	M24X1.5	85
22L	M30X2	115	20S	M30X2	125
28L	M36X2	135	25S	M36X2	180
35L	M45X2	220	30S	M45X2	260
42L	M52X2	345	38S	M52X2	370

Description:

- 1) For torques given in Table 3, an error of +10% is allowed;
- 2) The torque values given in Table 4 are based on the condition that the connected part is made of steel, and for connected part made of aluminum, the tightening torque equal to 60% of the corresponding torque in Table 3 shall apply and shall be rounded to the nearest integer after calculation;
- 3) For Parker rubber hoses, right-angle joints and tee joints, the torque is to be selected according to the name and specification, and for ordinary rubber hoses, right-angle joints and tee joints, the torque is to be selected according to the thread specification.

For example:

- 1) F481 CACF 2815 16: F481 for crimping form and hose type, CACF for joint type at both ends, CA for 24° conical swivel nut with O-ring, CF for 90° elbow of 24° conical swivel nut with O-ring, and 2815 for connection specification of joint at both ends of hose. According to this, the torque selected for end 28 is 135N.m, and the torque selected for end 15 is 58N.m;
- 2) F412 SN CACF 1210 06: SN represents heavy pressure hose, the torque at end 12 is 63 N.m, and the torque at end 10 is 53 N.m;
- 3) EW15LOMDA3C: EW represents a right-angle combination fitting. The torque value selected from Table 1 according to 15L is 32 N.m.

Table 4: Tightening torque of ordinary bolts (unit: N.m)

Strength grade of bolt	Yield strength N/MM <sup>2</sup>	Nominal diameter of bolt mm				
		6	8	10	12	14
		Tightening torque N·m				
4.6	240	4~5	10~12	20~25	36~45	55~70
5.6	300	5~7	12~15	25~32	45~55	70~90
6.8	480	7~9	17~23	33~45	58~78	93~124
8.8	640	9~12	22~30	45~59	78~104	124~165
10.9	900	13~16	30~36	65~78	110~130	180~210
12.9	1080	16~21	38~51	75~100	131~175	209~278
Strength grade of bolt	Yield strength N/MM <sup>2</sup>	Nominal diameter of bolt mm				
		16	18	20	22	24
		Tightening torque N·m				
4.6	240	90~110	120~150	170~210	230~290	300~377
5.6	300	110~140	150~190	210~270	290~350	370~450
6.8	480	145~193	199~264	282~376	384~512	488~650
8.8	640	193~257	264~354	376~502	521~683	651~868
10.9	900	280~330	380~450	540~650	740~880	940~1120
12.9	1080	326~434	448~597	635~847	864~1152	1098~1464
Strength grade of bolt	Yield strength N/MM <sup>2</sup>	Nominal diameter of bolt mm				
		27	30	33	36	39
		Tightening torque N·m				
4.6	240	450~530	540~680	670~880	900~1100	928~1237
5.6	300	550~700	680~850	825~1100	1120~1400	1160~1546
6.8	480	714~952	969~1293	1319~1759	1694~2259	1559~2079
8.8	640	952~1269	1293~1723	1759~2345	2259~3012	2923~3898
10.9	900	1400~1650	1700~2000	2473~3298	2800~3350	4111~5481
12.9	1080	1606~2142	2181~2908	2968~3958	3812~5082	4933~6577

## 2.3 Key component moment table

### Fluid drive type

No.	Part	Torque Valve		Interval Hours (h)
		Ft. lbs	Nm	
1	Forklift assembly hoisting	38±4	52±5	50
2	Hoisting of platform assembly	38±4	52±5	50

### Electric drive type

No.	Part	Torque Valve		Interval Hours (h)
		Ft. lbs	Nm	
1	Assembling of wheel	89±9	120±10	50
2	Forklift assembly hoisting	38±4	52±5	50
3	Hoisting of platform assembly	38±4	52±5	50

## Chapter 3 Platform



### 3.1 Removal and installation of PCU

#### 3.1.1 Removal of PCU

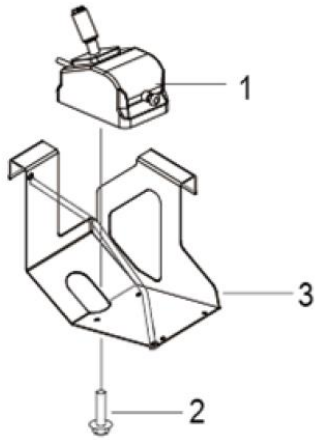

Fig. 3.1 PCU

1. PCU assembly 2. Bolt 3. Bracket

1. Remove the line connector of the PCU assembly from the PCU harness connector.
2. Pull the PCU harness out of the strap behind the platform.
3. Remove the 4 bolts from the PCU assembly and slowly remove the PCU assembly from the bracket.

#### 3.1.2 Installation of PCU

1. As shown in Figure 3.1, install part 1 PCU on part 3 bracket and secure it with part 2 bolt.
2. Fix the PCU harness to the bracket.
3. Connect the PCU assembly line connector to the PCU harness connector and install it securely.

### 3.2 Removal and installation of platform assembly

#### 3.2.1 Removal of platform assembly (S1932 II, S1932E II)

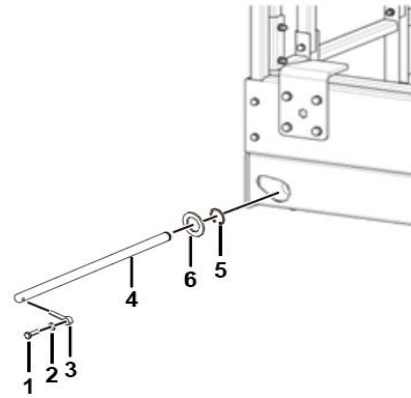



Fig. 3.2 Fork and platform connection fixing parts

1. Bolt 2. Washer 3. Safety pin 4. Pin 5. Retainer ring 6. Washer

1. Drive the lifting platform to a safe area (with safe operation space available around it, and without fork lifting interference point above it).
2. Disconnect the connector between the PCU assembly and the fork PCU harness.
3. Pull the PCU harness out of the platform and put it on the side of the fork (ensure that the harness will not be pressed when the platform is being lifted).
4. Attach the platform assembly to the sling of traveling crane, and ensure that the sling is connected firmly and reliably. Pass the sling

from the inside of the sling fixing point of the guardrail assembly.

5. As shown in Fig. 3.2, remove the connecting fixture between the main platform and the fork with a special tool.

 **CAUTION:** Lift the platform through the two anchor points on the guardrails on both sides, and lifting by one sling is not allowed.

6. Adjust the traveling crane, and remove the sliders on both sides from the lower bend plate of the main platform.
7. Adjust the position of sling, and lift the platform assembly smoothly to separate it from the fork. Then, place the platform assembly on a structure with sufficient supporting capacity.
8. Extend the extended platform by about 1m/3.28 ft.
9. Support the extended platform with a lifting equipment. Do not apply any lifting force.
10. Undo the fasteners on each wheel carrier of the platform, and remove the wheel carrier from the machine.
11. Remove the platform pulley from the machine.

12. Carefully slide the extended platform off the platform, and place it on a structure with sufficient supporting capacity.

 **CAUTION:** Be careful of the accessories that may fall away and hurt people during the hoisting process.

### 3.2.2 Installation of platform assembly (S1932 II, S1932 E II)

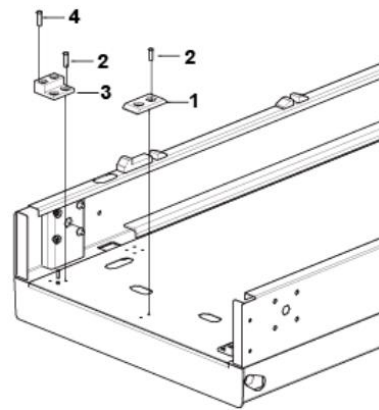

Fig. 3.3 Installation of main platform slider

1. Slider 2. Blind rivet 3. Slider 4. Blind rivet

1. Lift the main platform weldment and extended platform weldment onto the trolley to ensure firm and reliable positioning.
2. As shown in Fig. 3.3, place the sliders 1 and 3 on the main platform base plate, keep the sliders 1 & 3 and the main platform base plate hole concentric, and fasten them vertically with the blind rivets 2 and 4.
3. Place the extended platform on the extended



platform assembly trolley to ensure firm and reliable positioning.

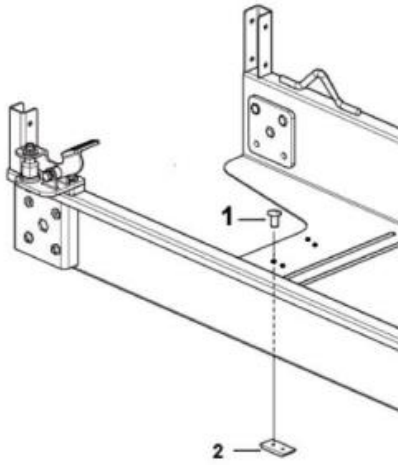

Fig. 3.4 Installation of extended platform slider

1. Blind rivet 2. slider

4. As shown in Fig. 3.4, place the slider 2 on the lower plane of the extended platform base plate; keep the blind rivet 1 and the slider 2 concentric with the extended platform base plate hole; and let the blind rivet 1 go through from top to bottom to fix the slider 2 on the extended platform base plate to ensure firmness and reliability.

Note: There is one slider on each side (left/right); The slider's chamfered end faces downwards during installation.

5. Install the wheels and wheel frame, please refer to 3.4.2.
6. Install the extended platform pedal, please refer to 3.3.2.

**!** CAUTION: Pull and push the extended platform after installing the pedal to test whether the spring pin can perform limitation effect and does not interfere with the stopper.

7. Install the guardrail assembly to the extended platform and the main platform.
8. After installing the platform assembly, apply evenly the lithium-based grease to the contact surface between the bending plate on the bottom of the platform assembly and the slider. Lift the platform assembly by four lifting points on the main platform to the position above the fork, and then lower it from the slider hole of the platform. Let the fork slider enter into the platform slide first, then slowly push the platform into place, and adjust the clearance between the slider and the slide to no more than 1 mm/0.04 in with the padding plate.
9. Adjust the crane to align the rectangular tube hole of the uppermost layer of fork with the main platform hole. As shown in Fig. 3.2, use a special tool to thread pin 4, and tighten one end of the pin with bolt 1, washer 2 and pin 3 to specified torque. The other end is fitted

into the retainer ring with a circlip pliers.

 CAUTION:

Pay attention to safety during hoisting. Do not let any part of the body under the hoisted object. If the sling is damaged, replace it immediately.

### 3.2.3 Removal of platform assembly (S2632 II , S2632E II , S46 II , S46E II , S4650 II , S4650E II )

1. Drive the lifting platform to a safe area (with safe operation space available around it, and without fork lifting interference point above it).
2. Pull out the connector between the PCU assembly and the fork PCU harness.
3. Pull the PCU harness out of the platform and put it on the side of the fork (ensure that the harness will not be pressed when the platform is being lifted).

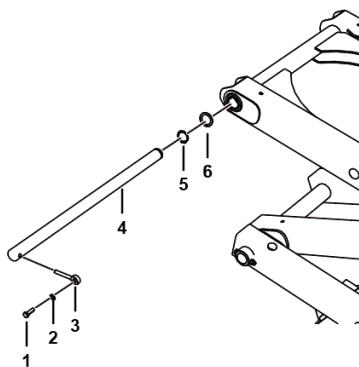

Fig. 3.5 Front connection between fork and

platform

1. Bolt 2. Washer 3. Safety pin 4. Pin 5.

Retainer ring 6. Washer

4. As shown in Fig. 3.5, remove the connecting pin between the main platform and the fork with a special tool.

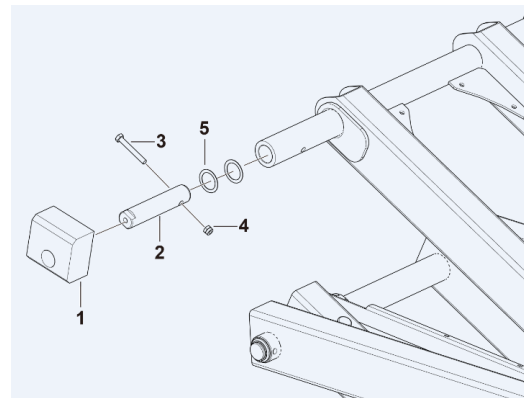

Fig. 3.6 Rear connection between the fork and platform

1. Slider 2. Half shaft 3. Bolt 4. Nut 5. Retainer ring
5. As shown in Fig. 3.6, use a special tool to remove the half shafts connecting the slider and the fork assembly at the left and right sides of the platform. Remove the slider.
6. Attach the platform assembly to the sling of traveling crane, and ensure that the sling is connected firmly and reliably. Pass the sling from the inside of the sling fixing point of the guardrail assembly.

**!** CAUTION: Lift the platform through the two anchor points on the guardrails on both sides, and lifting by one sling is not allowed.

7. Adjust the position of sling, and lift the platform assembly smoothly to separate it from the fork. Then, place the platform assembly on a structure with sufficient supporting capacity.
8. Extend the extended platform by about 1 m/3.28 ft.
9. Support the extended platform with a lifting equipment. Do not apply any lifting force.
10. Undo the fasteners on each wheel carrier of the platform, and remove the wheel carrier from the machine.
11. Remove the platform pulley from the machine.
12. Carefully slide the extended platform off the platform, and place it on a structure with sufficient supporting capacity.

**!** CAUTION: be careful of not being hit by falling workpieces during the lifting process

### 3.2.4 Installation of platform assembly (S2632 II, S2632 E II, S46 II, S46 E II, S4650 II, S4650 E II)

1. Lift the main platform and extended platform onto the trolley, and ensure firm and reliable positioning.

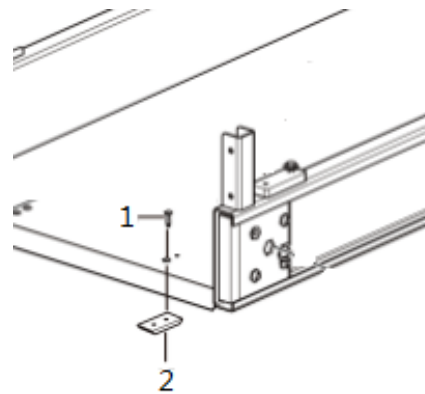

Figure 3.7 Extended platform

1. Blind rivet 2. Slider

2. As shown in Fig. 3.7, place part 2 on the lower plane of the extended platform base plate, keep part 1 and part 2 concentric with the extended platform base plate hole, and thread part 1 from top to bottom, and fix part 2 on the extended platform base plate to ensure firmness and reliability.

**!** CAUTION: The slider's chamfered end faces downwards during installation.

3. Install the wheels and wheel frame, please refer to 3.4.2.
4. Install the extended platform pedal, please

refer to 3.3.2.

 CAUTION: Pull and push the extended platform after installing the pedal to test whether the spring pin can perform limitation effect and does not interfere with the stopper.

5. Install the guardrail assembly to the extended platform and the main platform.
6. After installing the platform assembly, apply evenly the lithium-based grease to the contact surface between the bending plate on the bottom of the platform assembly and the slider.
7. Hoist the platform assembly to the position above the fork, and adjust the slider above the fork so that the side far from the hole faces up. Adjust the traveling crane, first assemble the fork left slider and the half shaft, and install the washer between the left slider and the half shaft to ensure that the single-side clearance between the slider and the platform slide is 1~2 mm/0.039 ~ 0.079 in. Then, install the half shaft into the fork end hole, and tighten it with the bolt and nut to specified torque.

 CAUTION: assemble one side slider and axle shaft first, and then assemble the other side after lowering the platform.

8. Adjust the crane to align the rectangular tube hole of the uppermost layer of fork with the main platform hole. Use a special tool to thread the pin, and tighten one end of the pin with the bolt, washer and safety pin to specified torque. The other end is fitted into the retainer ring with circlip pliers.

 CAUTION: Pay attention to safety during hoisting. Do not let any parts of the body be under the hoisted object. If the sling is damaged, it should be replaced immediately.

### 3.2.5 Folding of platform guardrail

The S1932 II/S1932E II/S2632E II/S2632 II platform guardrail system consists of a folding guardrail part of the extended platform and a folding guardrail part of the main platform. All parts are fixed in place by 4 D-pins.

1. Fully lower the platform and lock the extended platform.
2. Remove the PCU;
3. Remove the M-type fixing seat between the main platform and the extended platform

- guardrail from the inside of the platform and place it inside the platform;
4. Remove the two D-pins at the front part of the extended platform from the inside of the platform.
  5. Turn inward the front guardrail of the extended platform with the left/right guardrail of the extended platform not tipping over. Pay attention to not putting your hands at the positions where there is a pinching risk.
  6. Reinstall the two D-pins to the guardrail bracket on each side;
  7. Turn inward the left guardrail of the extended platform with the right guardrail of the extended platform not tipping over. Pay attention to not putting your hands at the positions where there is a pinching risk.
  8. Turn inward the right guardrail of the extended platform. Pay attention to not putting your hands at the positions where there is a pinching risk.
  9. Remove the two D-pins on the upper part of the main platform door rail;
  10. Push the door guardrail inward from the ladder or the ground with the left/right

guardrail of the main platform not tipping over. Pay attention to not putting your hands at the positions where there is a pinching risk.

11. Push the left guardrail of the main platform inward from the ladder or the ground. Pay attention to not putting your hands at the positions where there is a pinching risk; At the same time, prevent the left/right guardrail of the main platform from tipping over; Push the right guardrail of the main platform inward from the ladder or the ground. Pay attention to not putting your hands at the positions where there is a pinching risk;
12. Reinstall the two D-pins to the guardrail of each side.

The S4650II/S4650EII platform guardrail system consists of a folding guardrail of the extended platform and a folding guardrail of the main platform. All parts are fixed in proper places by four D-pins.

1. Fully lower the platform and lock the extended platform.
2. Remove the PCU;

3. Remove the M-type fixing seat between the main platform and the extended platform guardrail from the inside of the platform and place it in the platform;
  4. Remove the two D-pins at the front part of the extended platform from the inside of the platform.
  5. Turn inward the front guardrail of the extended platform with the left/right guardrail of the extended platform not tipping over. Pay attention to not putting your hands at the positions where there is a pinching risk.
  6. Reinstall the two D-pins to the guardrail bracket on each side;
  7. Turn inward the left guardrail of the extended platform with the right guardrail of the extended platform not tipping over. Pay attention to not putting your hands at the positions where there is a pinching risk.
  8. Turn inward the right guardrail of the extended platform. Pay attention to not putting your hands at the positions where there is a pinching risk.
  9. Remove the two D-pins on the left and right sides of the main platform door rail;
  10. Push the door rail inward from the ladder or the ground with the left/right guardrail of the main platform not tipping over. Pay attention to not putting your hands at the positions where there is a pinching risk.
  11. Rotate the semi-swing gate from the ladder or the ground until the right and left guardrails can be folded smoothly. Pay attention to not putting your hands at the positions where there is a pinching risk. At the same time, prevent the left and right guardrails of the main platform from tipping over.
  12. Reinstall the two pins to the guardrail of each side.
- The S2646 II /S2646E II /S3246 II /S324E II /S4046 II /S4046E II platform guardrail system consists of a folding guardrail of the extended platform and a folding guardrail of the main platform. If all parts of the platform are equipped with six D-pins fixed in place, fold the guardrail as follows.
1. Fully lower the platform and lock the extended platform.

2. Remove the PCU;
  3. Remove the M-type fixing seat between the main platform and the extended platform guardrail from the inside of the platform and place it in the platform;
  4. Remove the two D-pins at the front part of the extended platform from the inside of the platform.
  5. Turn inward the front guardrail of the extended platform with the left/right guardrail of the extended platform not tipping over. Pay attention to not putting your hands at the positions where there is a pinching risk.
  6. Reinstall the two D-pins to the guardrail bracket on each side;
  7. Turn inward the left guardrail of the extended platform with the right guardrail of the extended platform not tipping over. Pay attention to not putting your hands at the positions where there is a pinching risk.
  8. Turn inward the right guardrail of the extended platform. Pay attention to not putting your hands at the positions where there is a pinching risk.
  9. Remove the two D-pins above the main platform door rail;
  10. Fold the left and right guardrails of the platform door into the platform
  11. Remove the two D-pins on the left and right sides of the main platform door rail;
  12. Push the door rail inward from the ladder or the ground with the left/right guardrail of the main platform not tipping over. Pay attention to not putting your hands at the positions where there is a pinching risk.
  13. Rotate the semi-swing gate from the ladder or the ground until the right and left guardrails can be folded smoothly. Pay attention to not putting your hands at the positions where there is a pinching risk. At the same time, prevent the left and right guardrails of the main platform from tipping over.
  14. Reinstall the pins to the guardrail of each side.
- If all parts of the platform S2646 II/S2646E II/S3246 II/S3246E II/S4046 II/S4046E II are equipped with four D-shaped pins and fixed in proper places, the guardrail shall be folded as

follows.

1. Fully lower the platform and lock the extended platform.
2. Remove the PCU;
3. Remove the M-type fixing seat between the main platform and the extended platform guardrail from the inside of the platform and place it in the platform;
4. Remove the two D-pins at the front part of the extended platform from the inside of the platform.
5. Turn inward the front guardrail of the extended platform with the left/right guardrail of the extended platform not tipping over. Pay attention to not putting your hands at the positions where there is a pinching risk.
6. Reinstall the two D-pins to the guardrail bracket on each side;
7. Turn inward the left guardrail of the extended platform with the right guardrail of the extended platform not tipping over. Pay attention to not putting your hands at the positions where there is a pinching risk.
8. Turn inward the right guardrail of the extended platform. Pay attention to not putting your hands at the positions where there is a pinching risk.
9. Remove the two D-pins above the main platform door rail;
10. Fold the left and right guardrails of the platform door into the platform
11. Remove the two D-pins on the left and right sides of the main platform door rail;
12. Fold the upper half of the main platform door to the outside;
13. Reinstall the pins to the guardrail of each side.
14. Remove the bolts, washers and butterfly nuts on the right side of the main platform door;
15. Push the door rail inward from the ladder or the ground with the left/right guardrail of the main platform not tipping over. Pay attention to not putting your hands at the positions where there is a pinching risk.
16. Rotate the semi-swing gate from the ladder or the ground until the right and left guardrails can be folded smoothly. Pay attention to not putting your hands at the



positions where there is a pinching risk. At the same time, prevent the left and right guardrails of the main platform from tipping over.

17. Install the removed bolts, washers and butterfly nuts back to the guardrail.

### 3.3 Removal and installation of pedal

#### 3.3.1 Removal of pedal

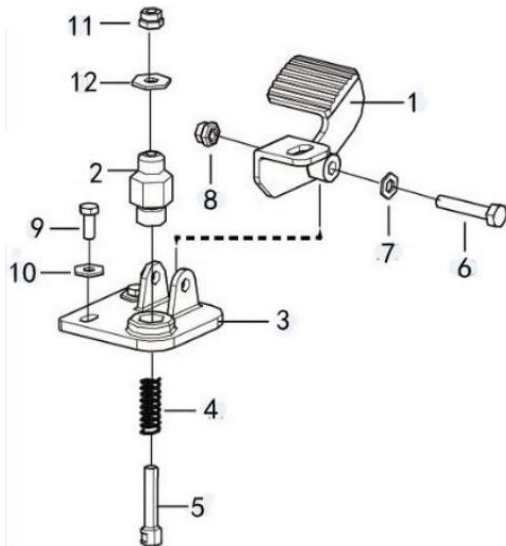



Figure 3.11 Pedal

1. Pedal 2. Spring seat 3. Mount 4. Spring 5. Spring pin 6. Bolt 7. Washer 8. Nut 9. Bolt 10. Washer 11. Nut 12. Washer

1. As shown in Fig. 3.11, first remove the parts 11 and 12, then remove the parts 6, 7 and 8 on the pedal, and pull the pedal 1 out of the spring pin 5 and mount 3.
2. Release the spring seat 2 from the mount 3

with a wrench and remove the spring 4 and the spring pin 5 from the spring seat 2.

 **CAUTION:** The nut cannot be used again after removal.

#### 3.3.2 Installation of pedal

1. As shown in Fig. 3.11, thread the spring 4 and the spring pin 5 through the part 3 and install them into the spring seat 2, and fix the mount 3 on the extended platform with the bolt 9 and the washer 10 and tighten it with a wrench.
2. Install the pedal 1 on the spring seat 2 and the mount 3, and fix it firmly with parts 6, 7, 8, 11 and 12 respectively. Before tightening, place a gasket of 4 mm/0.158 in on the lower side of the spring pin, and ensure that the pedal moves upward and downward freely.

 **CAUTION:** after the assembly is completed, pull in and push out the extension Platform to test whether the spring pin can play a limiting role and do not interfere with the stopper.

### 3.4 Removal and installation of wheel frame and wheels

#### 3.4.1 Removal of wheel frames and wheels

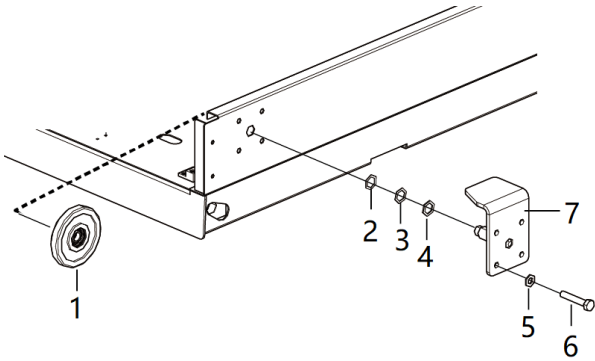

Fig. 3.12 Disassembly and Assembly of Main Platform Wheel Frames and Wheels

1. Wheel assembly 2. Adjusting shim 3.

Adjusting shim 4. Adjustment shim 5. Washer 6.

Bolt 7. Wheel frame

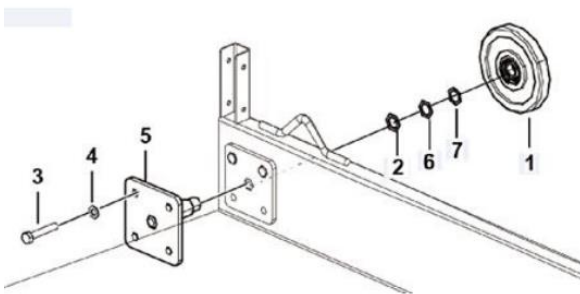

Fig. 3.13 Removal and installation of extension platform wheel frame and wheels

1. Wheel assembly 2. Adjusting shim 3. Bolt 4.

Washer 5. Wheel frame 6. Adjusting shim 7.

Adjusting shim

1. First remove the bolt and washer from the

wheel frame, and slowly extract the four wheel frames from the wheels and the platform side plate.

2. Sequentially take out the wheels from the platform gap, and extract the extended platform from the main platform.

#### 3.4.2 Installation of wheel frames and wheels

1. Assemble the main platform wheel assembly to the main platform wheel frame, and the extended platform wheel assembly to the extended platform wheel frame respectively.

2. Install the wheel frames and wheels in various places. During assembly, an adjusting shim shall be inserted between the wheel frame and the wheel to adjust the lateral shaking amount of the extended platform. Pull out the extended platform completely, during which the lateral shaking amount shall not exceed 3 mm/0.118 in, and ensure smooth sliding of the extended platform.

3. Secure the wheel frame to the platform using the part bolt washer, tighten it to

specified torque.



CAUTION: the large beveled side of the wheels for the main platform is located on the inside of the platform, and the large beveled side of the wheels for the extension platform is located on the outside of the platform.

- Wheel frame tightening reference torque:

32±3 N.m



Caution: Apply AT262 to the bolt surface, and then fasten it reliably with tools without deformation.

Adhesive application method: Apply a circle of adhesive to the male thread. The width of the applied adhesive is 3~5 teeth. The thread teeth shall be full of the adhesive. The first tooth of the thread does not need to be coated with the adhesive.

### 3.5 Removal and installation of semi-swing gate

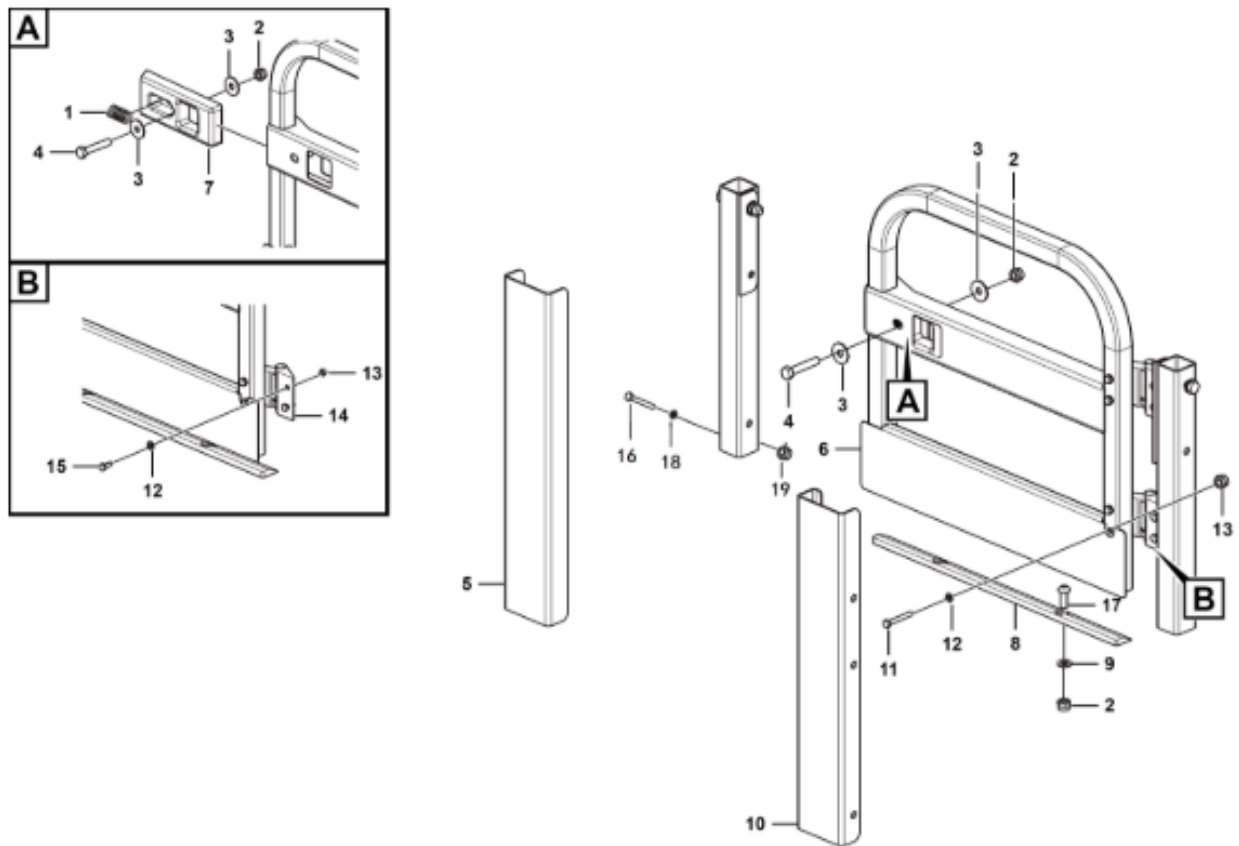

Fig. 3.14 Removal and installation of semi-swing gate

1. Spring 2. Nut 3. Washer 4. Bolt 5. Left door sill seam 6. Door 7. Plastic block 8. Clearance adjustment plate 9. Washer 10. Right mounting plate 11. Bolt 12. Washer 13. Nut 14. Spring hinge 15. Bolt 16. Bolt 17. Screw 18. Washer 19. Nut

#### 3.5.1 Removal of semi-swing gate

- As shown in Fig. 3.14, remove the fasteners of the fixing part 6 of the door, remove the spring hinge of part 14, and slowly remove the swing gate from the guardrail.
- Remove the bolts and other fasteners of part 4, and remove the plastic block of part 7 and the spring of part 1.

#### 3.5.2 Installation of the semi-swing gate

- Install the plastic block of part 7 and the spring of part 1 into the swing gate and fasten it with bolts and washers. Slightly tighten here to ensure smooth sliding of the plastic block.
- Fix the semi-swing gate on the platform with the spring hinge of part 14 and fasten it with parts 11,

12 and 13.

3. During assembly, note that the lower edge of the door is parallel to the main platform base plate, and the door should be opened and closed smoothly without jamming. After the door is pushed open, it should freely rebound back to the original position and be locked tightly, and the limit should be reliable. After installation, it shall be ensured that the revolving door rotates smoothly without sticking.

Note: S1932II is used as an example for the assembly of the revolving door shown in the figure, and other models are similar.



## Chapter 4 Fork





#### 4.1 Removal of fourth fork (S1932 II, S1932E II, S2632 II, S2632E II, S2646 II, S2646E II)

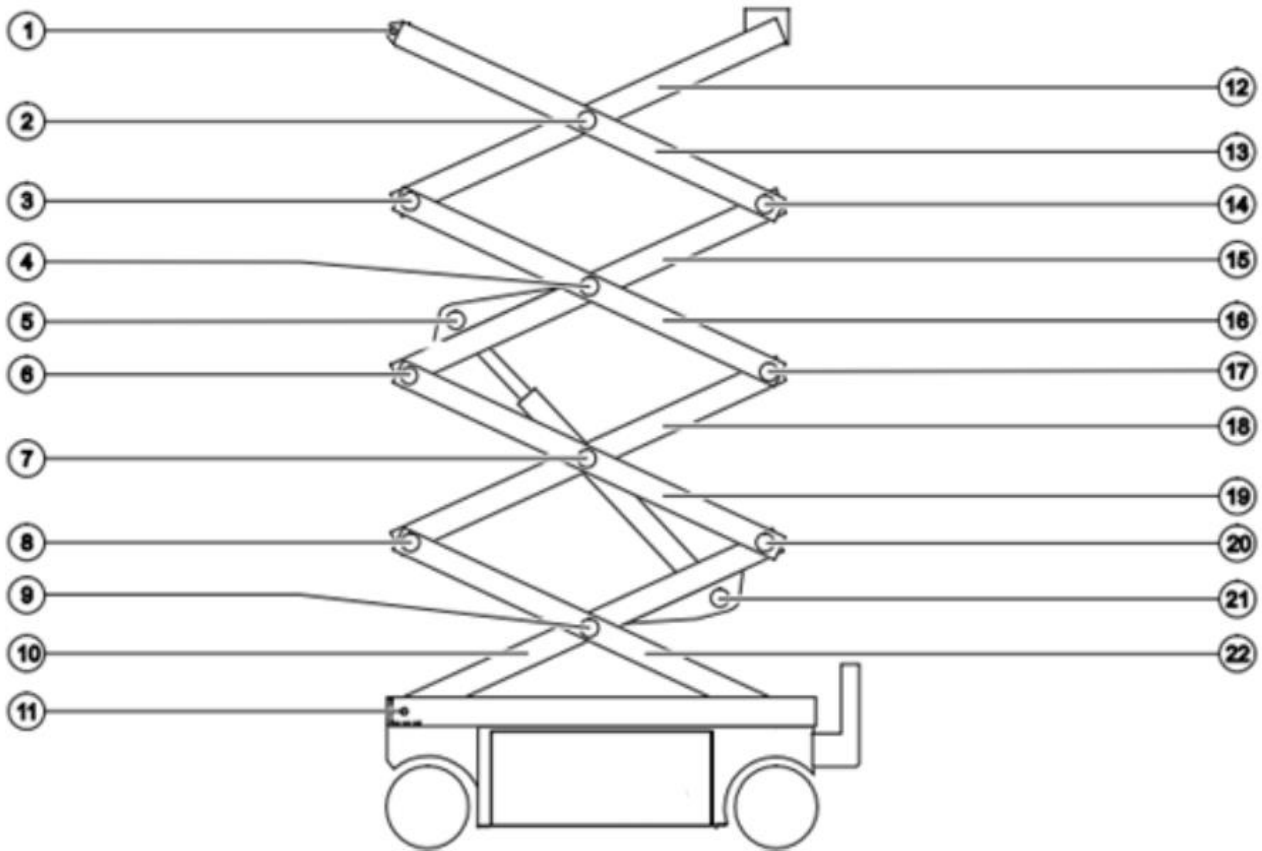



Fig. 4.16 Forth fork assembly

- |                                 |                               |   |
|---------------------------------|-------------------------------|---|
| 1. # 5 pin                      | 9. No.1 center pin            | 17. #3 pin (non-steering end)                 |
| 2. No.4 center pin              | 10. #1 inner arm              | 18. #2 inner arm                              |
| 3. #4 pin (steering end)        | 11. #1 pin                    | 19. #2 outer arm                              |
| 4. #3 center pin                | 12. #4 inner arm              | 20. #2 pin (non-steering end)                 |
| 5. Lower cylinder rod end shaft | 13. #4 outer arm              | 21. Lower lift cylinder barrel cylinder shaft |
| 6. #3 pin (steering end)        | 14. #4 pin (non-steering end) | 22. #1 outer arm                              |
| 7. #2 center pin                | 15. #3 inner arm              |   |
| 8. #2 pin (steering end)        | 16. #3 outer arm              |   |

 **WARNING:** danger of personal injury

This procedure requires specific maintenance skills, lifting equipment and a suitable workshop. Attempting this process without these skills and tools may result in death or serious injury, as well as serious component damage. It is strongly recommended to seek services from the dealer.

 **CAUTION:** During removal of the hose assembly or connector, the connector and the O-ring at the hose end must be replaced (if equipped). All connections must be tightened to the specified torque during installation. See the specification for selection of tightening torque of the lifting platform

1. Remove the platform.
2. Support and secure the entrance ladder to the appropriate lifting equipment, remove the fasteners from the entrance ladder, and then remove the entrance ladder from the machine.
3. Remove the cable harness on the wiring plate of outer arm #4.

 **CAUTION:** Danger of component damage

If the cable is kinked or squeezed, it may be damaged.

4. Remove the cable harness from the third layer to fourth layer of wiring plate of the fork.
5. Connect the overhead crane strap on the #4 outer arm on the tank side.
6. Remove securing fasteners of outer retainer ring, washer and #4 center pin
7. Remove #4 center shaft with a soft metal hammer and remove the 3rd to 4th layer fork wiring plate.
8. Remove the securing fastener of pin 4 from the non-steering end of the machine.
9. Remove the pin #4 from the non-steering end of machine by using soft metal hammer, and then remove the #4 outer arm from the machine.

 **WARNING:** Risk of crushing

When removed from the machine, the #4 outer arm may be out of balance and fall if it is not properly supported.

10. Attach the overhead crane with a sling to #4 inner arm.
11. Remove the securing fastener of pin #4.
12. Remove pin #4 from the steering end by

using a soft metal hammer. Remove #4 inner arm from the machine.

13. Remove the cable harnesses from the wiring plate and wiring ring of #3 inner arm and lay them aside.

 CAUTION: Danger of component damage

If the cable is twisted or squeezed, it may be damaged

14. Connect the sling on the overhead crane to the #3 outer arm on the ground control side.
15. Remove the fastener of #3 center pin.
16. Remove the wiring plate of #3 arm.
17. Remove #3 center pin (part 4) with a soft metal hammer.
18. Remove the securing fastener from #3 pin (part 17) at the non-steering end.
19. Knock out half of #3 pin (part 17) from the non-steering end of the machine with a soft metal hammer. Remove #3 outer arm on the tank side (part 16) from the machine.

 CAUTION: risk of crushing

When being removed from the machine, if not supported properly, the #3 outer arm on the ground control side may be out of balance and fall off.

20. Attach the sling on the overhead crane and connect it to the #3 outer arm on the battery box side (Part 16).

21. Remove the securing fastener from the #3 center pin (Part 4) on the side of battery.

22. Remove the #3 pin (Part 17) with a soft metal hammer.

23. Remove the #3 outer arm (part 16) on the side of the battery box from the machine.

 CAUTION: risk of crushing

When removed from the machine, the #3 outer arm on the side of the battery box may be out of balance and fall off if it is not properly supported.

24. Attach the sling on the overhead crane to the lift cylinder rod end.

25. Remove the securing fastener from the lift cylinder rod end pin (part 5).

26. Remove the lower lift cylinder rod end pin (part 5) from the machine by using a soft metal hammer.

 WARNING: danger of personal injury

If the support is improper, the cylinder may fall off when removing the cylinder

shaft of the connecting rod end.

27. Place a cushion block on #1 inner arm cylinder plate (Part 10).

28. Lower the cylinder onto the cushion block.

29. Attach the sling on the overhead crane to #3 inner arm (part 15). Lift the arm to the vertical position.

30. Remove the securing fastener from pin #3 (part 6) at the steering end of the machine.

31. Remove pin #3 (part 6) from the steering end of the machine using a soft metal hammer. Remove #3 inner arm (part 15) from the machine.



WARNING: Risk of crushing

When removed from the machine, the #3 inner arm may become out of balance and fall if it is not properly supported.

32. Remove the cable harness from the wiring plate and wiring ring of #2 inner arm and put it aside.

33. Remove the securing fastener of outer retainer ring, washer and #2 center pin (part 7) on the tank side.

34. Remove the wiring plate from the machine.

35. Attach an overhead crane strap to the #2

outer arm at the ground control side.

36. Remove the securing fastener from #2 center pin (part 7) on the ground control side.

37. Remove the securing fastener from pin #2 (part 20) at the non-steering end.

38. Remove #2 pin (part 20) from the non-steering end of the machine using a soft metal hammer. Remove ground control side (part 19) #2 outer arm from the machine.



WARNING: Risk of crushing

When removed from the machine, if the #2 outer arm on the ground control side is not properly supported, it may be out of balance and fall.

39. Fasten the sling on the overhead crane strap to #2 outer arm on the battery box side (part 19).

40. Remove the outer retainer ring, washer and the securing fastener of the center pin #2 (part 7) on the battery box side.

41. Remove the center pin #2 (part 7) with a soft metal hammer.

42. Remove the #2 outer arm on the battery side.

 **WARNING:** danger of personal injury

When removed from the machine, the #2 outer arm on the battery box side may be out of balance and fall off if it is not properly supported.

43. Attach a sling on the overhead crane to the #2 inner arm (part 18).

44. Remove the securing fastener from pin 2 (part 8) on the steering end of the machine.

45. Remove pin #2 (part 8) using soft metal hammer. Remove #2 inner arm (part 18) from the machine.

 **WARNING:** Risk of crushing

When removed from the machine, the #2 inner arm may be out of balance and fall if it is not properly supported.

46. Connect the sling from the overhead crane to the #1 inner arm (part 10).

47. Raise the #1 inner arm (part 10) about 60 cm/1.97 ft.

48. Place a 10 cm/3.94 in×10 cm/3.94 in×1.2 m/3.94 ft long cushion block under #1 center pin (part 9) across both sides of the chassis. And lower the scissor arm onto the cushion block.

 **WARNING:** danger of personal injury

When the fork is lowered onto the safety arm, do not touch the moving parts with your hands.

49. Attach the overhead crane strap to the lift cylinder rod end (part 5).

50. Mark, disconnect and plug the hydraulic hose on the lift cylinder. Cover the connector on the cylinder.

 **WARNING:** danger of personal injury

The sprayed hydraulic oil can penetrate and burn the skin. Loosen the hydraulic connectors very slowly to gradually dissipate the oil pressure. Do not allow oil to squirt or spray.

51. Mark and disconnect the harness on the cylinder valve.

52. Mark and disconnect the harness of the platform pressure sensor.

Note: after replacing the fork assembly, the platform overload system must be calibrated.

53. Lift the lift cylinder to the vertical position.

54. Remove the pin securing fastener from the lift cylinder barrel end shaft (Part 21). Remove the pin with a soft metal hammer. Remove the lift cylinder from the machine.

 **WARNING:** Risk of crushing

If not properly supported and fixed to the lifting equipment, the lift cylinder will become unbalanced and fall down.

 **CAUTION:** Danger of component damage

When removing the cylinder from the machine, do not damage the valve or connector of the cylinder.

55. Attach the sling on the overhead crane to #1 inner arm (part 10) at the non-steering end. Lift the boom slightly and take out the stopper.

56. Remove the cable from the wiring ring of #1 arm and set it aside.

 **CAUTION:** Danger of component damage

If the cable is twisted or squeezed, it may be damaged

57. Attach the sling on the overhead crane to #1 outer arm (part 22). Do not apply any lifting force.

58. Remove the outer snap ring and securing fastener from #1 center shaft (part 11).

59. Remove the #1 center pin (part 9) on both sides using soft metal hammer.

 **WARNING:** danger of personal injury

When removing the pin, if it is not properly supported, the #1 outer arm may become unbalanced and fall.

60. Slide #1 outer arm (part 22) to the non-steering end and remove it from the machine.

61. Connect the sling from the overhead crane to the #1 inner arm (part 10). Don't lift it.

62. Remove the travel switch protection cover plate located in #1 inner arm and remove the upper/lower limit switch from the mounting plate.

63. Remove the securing fastener of the pin securing #1 inner arm to the end of the chassis. Remove the pin.

64. Remove #1 inner arm (part 10) from the machine.

 **CAUTION:** Danger of component damage

When removing #1 inner arm from the machine, make sure not to damage the limit switch.

 **WARNING:** danger of personal injury

During removal of the #1 inner arm from the machine, the #1 outer arm may become

unbalanced and fall if not properly supported.

## 4.2 Fourth layer fork assembly (S1932II, S1932EII, S2632II, S2632EII, S2646II, S2646EII)

### 1. Installation of first layer fork

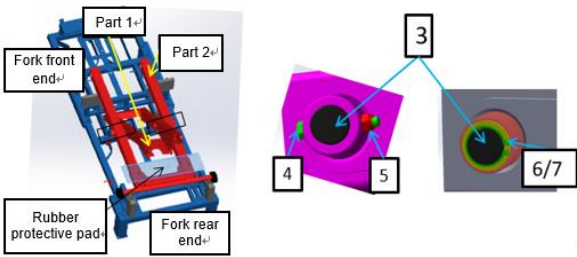

Fig. 4.17 Installation of first layer fork

1. First inner wall assembly
2. First outer wall weldment
3. Pin
4. Bolt
5. Nut
6. Washer
- 7.

#### Retainer ring

- a) As shown in Fig. 4.17, place parts 1 and 2 to the fork part trolley, and pay attention to the direction;
- b) Adjust the positions of first layer of inner frame and first layer of outer beam to align the middle shaft hole, knock in the shaft 3 on each side of the fork, and pay attention to the shaft end with circlip facing inward; The clearance between the inner frame and outer beam should be 0.5 mm/0.02 in, which also applies to the following related parts.

- c) Insert the part 4 into the outer hole of the part 3, adjust it so that the pin through hole of the part 3 is concentric with the clamping hole of the outer beam shaft sleeve, and install the part 5. Note that the bolt fixed at the shaft end shall be inserted from the front end of the fork;
- d) Then install the part 6 into the end with circlip of the shaft 3; Then install the part 7 into the groove of the part 3 with circlip pliers;
- e) Tighten the part 4/5 with torque wrench; Note: use electric impact wrench to tighten the nut end, pay attention to the paint surface protection, and follow the requirements for nuts in other positions.

Tools: fork single-layer hanger, copper hammer, circlip pliers, torque wrench 16, electric impact wrench, sleeve 16#, rubber protective pad 900\*300

Tightening torque of part 5: 40±4 N.m

### 2. Lift cylinder (lower end) assembly

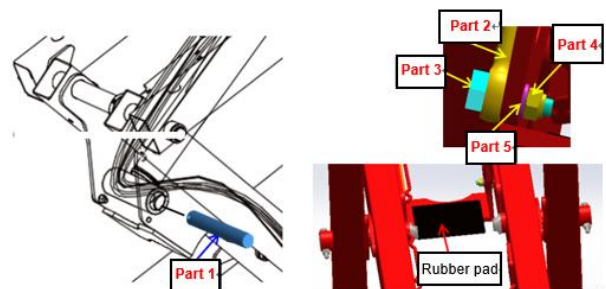

Fig. 4.18 Assembly of lift cylinder (lower end)

1. Pin 2. Safety pin 3. Bolt 4. Nut 5. Washer

- a) Before placing the oil cylinder, lay a rubber pad at the rear end of the inner frame ear plate beam to avoid damaging the oil cylinder;
- b) Use the traveling crane to lower the oil cylinder to the rear end of the inner frame, adjust the position of the lower installation position of the oil cylinder to make its mounting hole concentric with the mounting hole of the inner frame, and then smash the shaft of piece 1 into the shaft hole. Note that the hole end of the shaft faces outward, and smash it from the left side of the fork; Note: the cylinder valve block faces the chassis, on the underside of the cylinder;
- c) Confirm that the special sling is not damaged, the hoisting and mounting are firmly attached, and a safe distance is kept during hoisting;
- d) Put the piece 2 into the hole of the piece 1, adjust the mounting hole of the piece 2 mounting hole to align it to the lug plate of the inner frame, and fix it with the piece 3/4/5

and fasten it reliably; Note that the gasket is on the nut side;

Tools: rubber pad, copper hammer, torque wrench, sleeve, electric impact wrench

Tightening torque of Part 3:  $52 \pm 5$  N.m

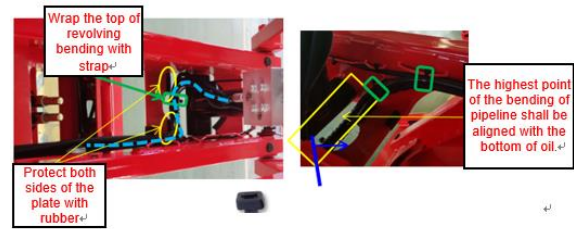

Fig. 4.19 Installation of first layer pipeline

- e) As shown in Fig. 4.19, the inlet, return pipe, fork harness and stay wire are arced on the lower side of the bottom end of the oil cylinder, as shown by the blue dotted line in the figure. When turning, the oil pipe harness is flush with the bottom end of the oil cylinder under the natural state of the arc outer dome; Note: the cable is not allowed to be completely tied, and there is a movable margin. All pipeline shall be bound to the routing round steel on the inner wall of the first layer fork, and the blue line position oil pipe shall be respectively wound with 500 mm/19.69 in long PVC protection. The PVC shall be tightly wound and both ends shall be fixed with black tape (the



subsequent PVC protection shall be the same as this requirement); Install rubber protectors at the positions with yellow circles, and then bind the pipeline;

Note: When cutting the excess part of the strap, leave a length of 1-3 mm/0.04-0.12 in, and the cut should be smooth without any sharp corners, as shown in Fig. 4.5; This also applies to the straps on the other positions;

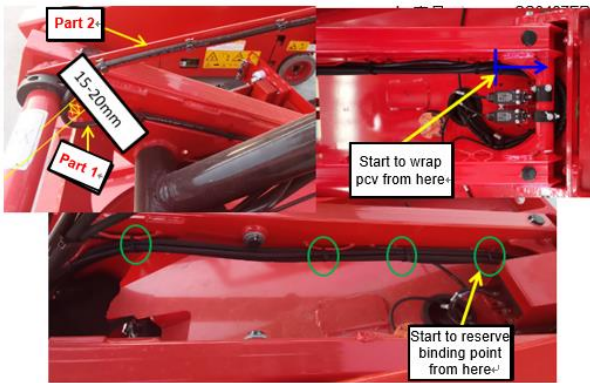

Fig. 4.20 Installation of first layer pipeline

1. PCU harness 2. Wiring plate assembly

f) The PCU harness is bound along the fork routing round steel. The key control points are as follows:

- 1) Reserve 1.5 m/4.92 ft at the fixed pipe clamp of the harness oil pipe, then lay it to the back of the oil cylinder and bind it along the round steel (green circle);
- 2) When the PCU harness is arced to the wiring plate, the inner side of the

harness fork shall be close to the round pipe at the rear end of the inner frame, as shown in Fig. 4.20. In the natural state, the harness shall be arced to the inner side, 15-20 mm away from the fixing ring;

- 3) Install the strap to the wiring plate fixing hole, smooth the harness, and use the installed strap to bind the harness firmly;
- g) The 2 main valve oil pipes in the chassis are wrapped with 500 mm/19.7 in long PVC from 50-60 mm/1.97-2.36 in after the last binding point of the fork frame for protection, as shown in Fig. 4.20.

### 3. Installation of second layer fork

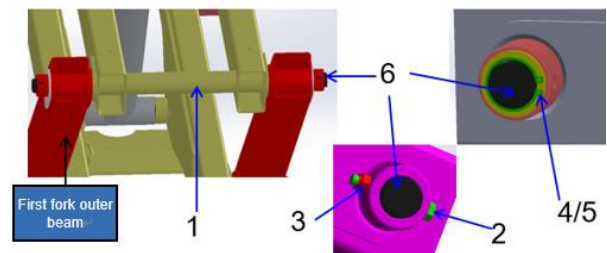

Fig. 4.21 Installation of second layer fork

1. Second inner arm assembly 2. Bolt 3. Nut 4. Washer 5. Retaining ring 6. Pin

a) Lift the second-layer inner frame to the upper side of the first-layer inner frame, between the two arms of the first-layer outer

beam, and pay attention to the placement

direction of the inner frame

- b) Adjust the outer beam of the first-layer fork to be concentric with the front end shaft hole of the second-layer fork inner frame, and then knock the part 6 in. Note that the shaft end with circlip faces inward and smash in from the right side of the fork;
- c) Thread the part 2 into the through hole 6, adjust the pin 6 so that the through hole is concentric with the bolt hole of the outer beam shaft sleeve, and install the parts 2 and 3. Note that the bolt fixed at the shaft end shall be inserted from the front end of the fork; Tighten the part 2/3;
- d) Install the part 4 into the end of the shaft circlip 6 and install the part 5 into the groove 6 with a circlip pliers.

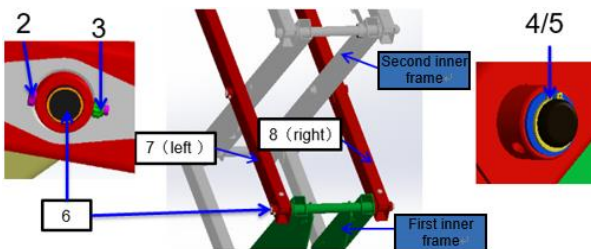

Fig. 4.22 Installation of second layer fork

2. Bolt 3. nut 4. washer 5. retaining ring 6. pin
7. Left weldment of outer arm 8. Right

weldment of outer arm

- e) Lift and place parts 7 and 8 to both sides of the inner frame of the first layer respectively, pay attention to the placement direction of the outer beam (surface with the rubber plug hole facing upward), and pay attention to distinguish between left and right;

Note: when the outer beam is placed, it must be placed steadily before the other side is lifted.

After the outer beam is placed, the outer beam anti-falling tooling must be used and placed in the middle of the fork. Other subsequent layers shall follow this requirement;

- f) Adjust the parts 7 and 8 to make that the second-layer outer beam is concentric with the rear end shaft hole of the first-layer inner frame, and then knock the part 11 in. Note that the shaft end with circlip faces inward and it is knocked in from the right side of the fork;
- g) Thread part 2 into the left hole of part 6, adjust the pin through hole so that it is concentric with the bolt hole of the outer beam shaft sleeve, and install the parts 2

and 3. Note that the bolt fixed at the shaft end shall be inserted from the front end of the fork; Tighten the part 2/3;

h) Load the part 4 into the side of the 6-axis circlip, and then load the part 5 into the groove of part 6 with circlip pliers.

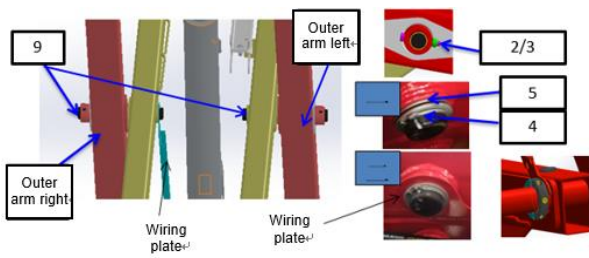

Fig. 4.23 Installation of second-layer fork

2.Bolt 3.Nut 4.Washer 5.Retaining ring 9.Pin

i) Adjust the position of the second layer inner frame and outer beam, align the middle shaft holes, knock the shaft 9 into both sides, keep the shaft end with circlip facing inward;

j) Thread the part 2 into the through hole of the part 9, adjust the direction and smash it, so that the pin hole through hole piece is concentric with the bolt hole of the outer beam tube, and install the parts 2 and 3. Note that the bolts fixed at the shaft end must be penetrated from the front end of the fork; Fasten the parts 2/3 (tightening torque  $40\pm 4$  N.m);

k) Clamp the opening end of the wiring plate to the right side of the fixed ring at the rear end of the first-layer inner frame, and install the other end to the inner side of the right-side shaft in the middle of the second-layer fork;

l) Install part 5 into the inner side of part 9 shaft (two on the left shaft and one wiring plate on the right shaft), and then install part 4 into the groove of part 9 with circlip pliers;

Tools: fork single-layer hanger, copper hammer, sleeve, torque wrench, electric impact wrench, circlip pliers

Tightening torque of part 3:  $40\pm 4$  N.m

#### 4. Assembly of fork protective arm

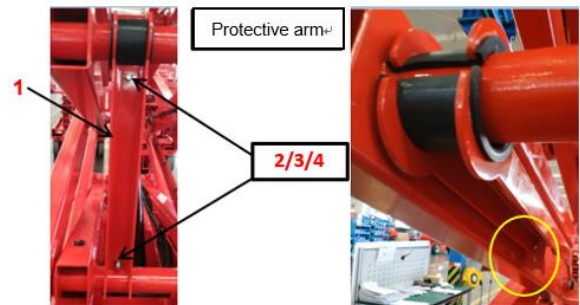

Fig. 4.24 Assembly of fork protective arm

1. Assembly of bending plate 2. Bolt 3. Washer 4. Nut

a) Use part 2/3/4 to assemble the bending plate of part 1. At this time, nuts are not tightened by hand;

b) Install the protective arm fitting to the rear

end of the second layer inner frame and tighten it;

- c) Adjust the protective arm position so that it moves to the left side of the inner frame rear tube, and the movable end is clamped to the inner frame support plate as shown in the yellow circle in the figure above.

Tools: electric impact wrench, sleeve, torque wrench

Part 2 tightening torque:  $52 \pm 5$  N.m

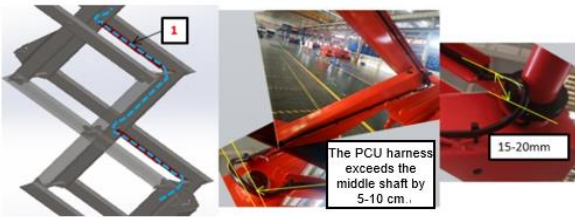

Fig. 4.25 Installation of second layer pipeline

1. Wiring plate assembly

- d) Smooth the PCU harness, fix it along the fixing hole of the wiring plate, and firmly tie the wire installed in the early stage;
- e) Lay the PCU harness passing around the middle shaft of the second-layer fork (PCU harness shall exceed the middle shaft by 5-10 mm/0.2-0.4 in) to the rear of the fork frame, and use the strap (every 200-250 mm/7.87-9.84 in) to fix it on the routing round steel on the right side of the second-

layer inner frame, as shown in Fig. 4.25;

- f) When the PCU harness is wound around the arc to the wiring plate, the harness needs to be close to the round pipe at the rear end of the inner frame, and wound inside the fork round steel, as shown in figure 4.25, the wiring harness is naturally wound around the arc on the inside, and the distance from the ring is 15-20mm/0.59-0.79in;
- g) Install the strap to the wiring plate fixing hole, smooth the harness, and use the installed strap to bind the harness firmly;

5. Installation of third layer fork

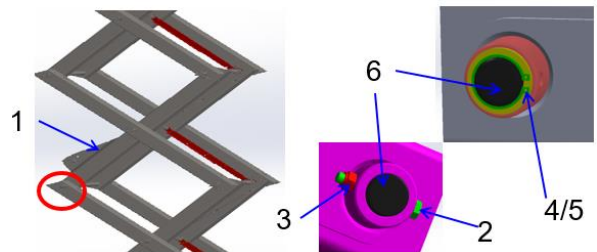

Fig. 4.26 Installation of third layer fork

- 1. Third inner arm assembly 2. Bolt 3. Nut 4.

Washer 5. Retaining ring 6. Pin

- a) Lift the third layer inner frame to the upper side of the second layer inner frame, between the two arms of the second layer outer beam, and pay attention to the

- placement direction (with the installation rubber plug hole facing upward);
- b) Adjust the outer beam of the second-layer fork to be concentric with the front end shaft hole of the three-layer fork inner frame, and then smash part 6 in. Note that the end of the shaft mounting circlip faces inward and smash in from the right side of the fork;
- c) Thread the part 2 into the through hole of the part 6, adjust the pin of the part 6 so that the through hole is concentric with the bolt hole of the outer beam tube, and install the part 2 and 3. Note that the bolts fixed at the shaft end shall be inserted from the front end of the fork; Tighten the part 2/3;
- d) Install the part 4 into the end of the shaft circlip 6 and install the part 5 into the groove 6 with a circlip pliers.

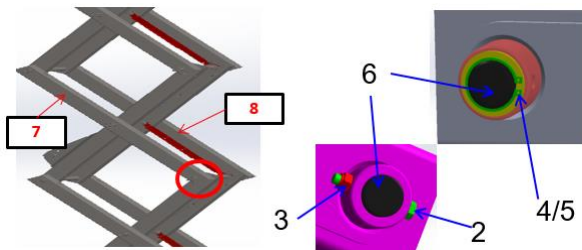

Fig. 4.26 Installation of third layer fork

2. Bolt 3. Nut 4. Washer 5. Retaining ring 6. Pin

7. Left weldment of outer arm 8. Right

weldment of outer arm

- e) Lift and place parts 7, 8 to both sides of the third layer inner frame respectively, pay attention to the placement direction of the outer beam (with the installation rubber plug hole facing upward), and pay attention to distinguish left and right;
- f) Adjust the parts 7 and 8 to make that the third layer outer beam is concentric with the rear end shaft hole of the second layer inner frame, and then knock the part 6 in. Note that the shaft end with circlip faces inward and it is knocked in from the right side of the fork;
- g) Thread part 2 into the left hole of part 6, adjust the pin through hole so that it is concentric with the bolt hole of the outer beam shaft sleeve, and install the parts 2 and 3. Note that the bolt fixed at the shaft end shall be inserted from the front end of the fork; Tighten the part 2/3;
- h) Load the part 4 into the side of the 6-axis circlip, and then load the part 5 into the groove of part 6 with circlip pliers.

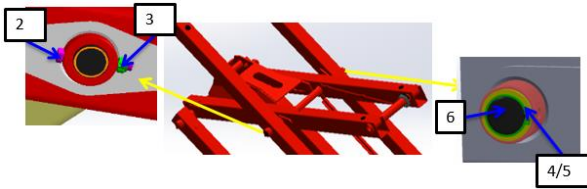

Fig. 4.27 Installation of third layer fork

2. Bolt 3. Nut 4. Washer 5. Retaining ring 6. Pin

- i) Adjust the positions of the three-layer inner frame and outer beam to align the middle shaft hole, smash the shaft of part 6 on both sides respectively, and pay attention to the shaft mounting circlip end facing inward; Note that the clearance between the inner frame and the outer beam is 0.5 mm/0.02 in;
- j) Thread the part 2 into the through-hole of the part 6, adjust the direction and then smash it in to make the pin through-hole and the outer beam tube through-hole concentric. Install the parts 2 and 3. Note that the bolt fixed at the shaft end should be inserted from the front end of the fork; Fasten the parts 2/3 (tightening torque 40±4 N.m);
- k) Install the second to third layers of wiring plate: clamp the open end of the wiring plate to the right side of the fixing ring at the rear end of the inner frame of the first layer, and install the other end to the inner side of the

right shaft in the middle of the fork of the second layer;

- l) Install the part 4 into the end of the circlip on the shaft of the part 6, and then install the part 5 into the groove of the part 6 with the circlip pliers;

Tools: copper hammer, sleeve, torque wrench, electric impact wrench, circlip pliers

Tightening torque of part 3: 40±4 N.m

#### 6. Lift cylinder (upper end) assembly

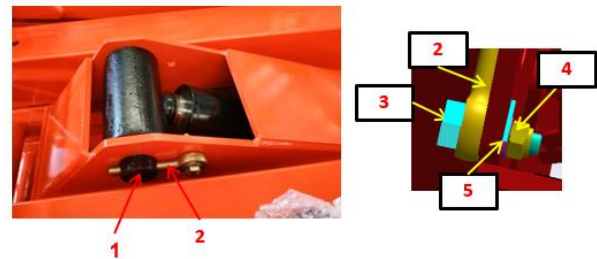

Fig. 4.28 Assembly of lift cylinder (upper end

1. Pin 2. Safety pin 3. Bolt 4. Nut 5. Washer

- a) Lift the front end of the lower cylinder, adjust the hole with the front side lug plate of the third-layer inner frame, and then smash the shaft of part 1. Note that the hole end of the shaft faces outward, and smash it from the left side of the fork;
- b) Insert the part 2 into the through hole of the part 1, adjust the mounting hole of the part 2 to mounting hole the ear plate, fix it with

the part 3/4/5, tighten to specified torque and draw the mark MARK; Note: the gasket is on the nut side;

Tools: pin, safety pin, bolt, nut, washer

Tightening torque of part 3:  $52 \pm 5$  N.m



Fig. 4.29 Installation of third layer pipeline

1. Wiring plate assembly

- c) Smooth the PCU harness, fix it along the fixing hole of the wiring plate, and firmly tie the wire installed in the early stage;
- d) Lay the PCU harness around the central axis of the three-layer fork (PCU harness shall exceed the central axis 5-10 mm/0.2-0.4 in) to the rear of the fork, and fix it on the round steel on the right side of the three-layer inner frame with strap (every 200-250 mm/7.87-9.84 in), as shown in Fig. 4.29;
- e) When the PCU harness arcs to the wiring plate, the harness shall be close tightly to the rear end circular tube of the inner frame and fork the inside of the circular steel, as shown in Fig. 4.29 in the natural state of the

harness, the arc shall be close to the inside, 15-20 mm/0.59-0.79 in from the circular ring.

- f) Install the strap to the wiring plate fixing hole, smooth the harness, and use the installed strap to bind the harness firmly;

7. Installation of fourth layer fork

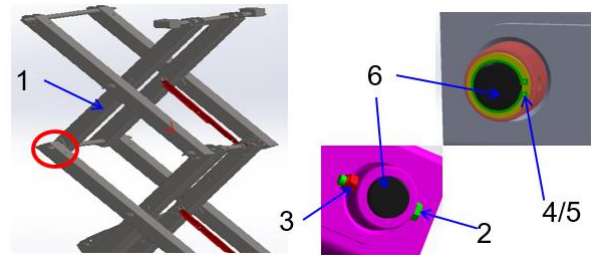

Figure 4.30 Installation of fourth layer fork

- 1. The fifth inner arm assembly 2. Bolt 3. Nut 4. Washer 5. Retaining ring 6. Pin
- a) Lift the fourth layer inner frame to the upper side of the third layer inner frame, and pay attention to place the side with rubber plug mounting hole in upward direction;
- b) Adjust the outer beam of the three-layer fork to be concentric with the front end shaft hole of the four-layer fork inner frame, and then smash the piece 6. Note that the end of the shaft mounting circlip end facing inward and smash in from the left side of the fork frame;
- c) Insert the piece 2 into the fixing hole of the piece 6, adjust the pin of the piece 6 to make

its through hole concentric with the bolt through hole of the outer beam, and install the piece 2/3. Note that the bolt fixed at the shaft end shall be inserted from the front end of the fork frame; Tighten the part 2/3;

- d) Install the part 4 into the end of the shaft circlip 6 and install the part 5 into the groove 6 with a circlip pliers.

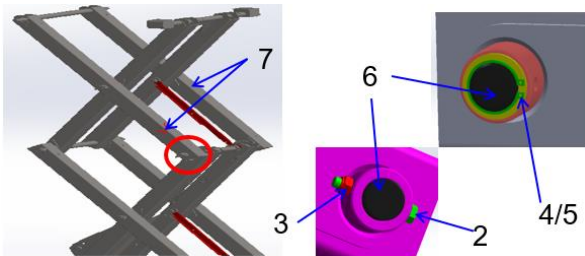

Fig. 4.31 Installation of fourth layer fork

2. Bolt 3. Nut 4. Washer 5. Retaining ring 6. Pin  
7. Fifth outer arm assembly

- e) Lift and place the two sides of the four-layer inner frame of Part 7 respectively, paying attention to the placement direction of the outer beam (with the mounting rubber plug hole facing upward);
- f) Adjust the four-layer outer beam of part 7 to be concentric with the shaft hole at the rear end of the three-layer inner frame, and then smash the part 6 into it. Note that the end of the shaft mounting circlip faces inward and

is smashed from the left side of the fork;

- g) Thread part 2 into the left hole of part 6, adjust the pin through hole so that it is concentric with the bolt hole of the outer beam shaft sleeve, and install the parts 2 and 3. Note that the bolt fixed at the shaft end shall be inserted from the front end of the fork; Tighten the part 2/3;
- h) Load the part 4 into the side of the 6-axis circlip, and then load the part 5 into the groove of part 6 with circlip pliers.

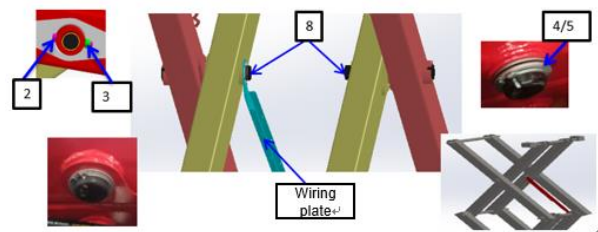

Fig. 4.32 Installation of fourth layer fork

2. Bolt 3. Nut 4. Washer 5. Retaining ring 8. Pin
- i) Adjust the positions of the inner frame and outer beam of the fourth floor to align the intermediate shaft hole, smash the shaft 8 on both sides respectively, and note that the end of the shaft mounting circlip faces inward; Note that the clearance between the inner frame and the outer beam is 0.5 mm/0.02 in;
- j) Insert part 2 into the through-hole of part 8,



adjust the direction and then hit it, so that the through-hole of the pin is concentric with the bolt hole of the axle sleeve of the outer beam. Install parts 2 and 3, pay attention to the bolts fixed at the shaft end should be penetrated from the front end of the fork frame; Fasten the parts 2/3 (tightening torque  $40\pm 4$  N.m);

- k) Installation of three to four layers of wiring plate: the opening end of the wiring plate is stuck to the right side of the fixing ring at the rear end of the three-layer inner frame, and the other end is installed on the inside of the right axis of the middle of the four-layer fork;
- l) Insert Part 4 into the Part 8 axis circlip end (two on the left axis, and one on the right axis have a wiring plate), and then use circlip pliers to load the Part 5 into the groove of the Part 8 axis;

Tools: copper hammer, sleeve, torque wrench, electric impact wrench, circlip pliers

Part 2/3 tightening torque:  $40\pm 4$  N.m

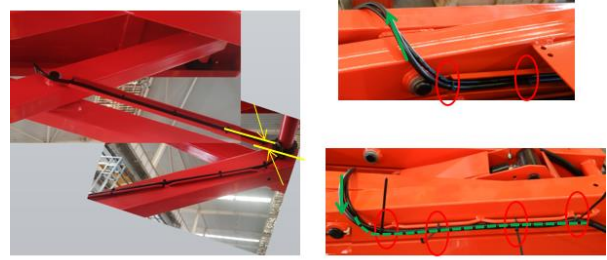

Fig 4.33 Installation of fourth layer pipeline

- m) Thread the PCU harness along the four-layer fork axis from the inner frame to the outer beam, and then bind it to the wiring round steel of outer beam, as shown in Figure 4.18.

Note: when there is a power harness, the outer beam routing round steel is bound with the PCU using the "8" binding method.

- n) After the completion of the harness sorting, it is not allowed to break or fall to the ground.

### 4.3 Removal of fifth layer fork (S3246 II, S3246 II)

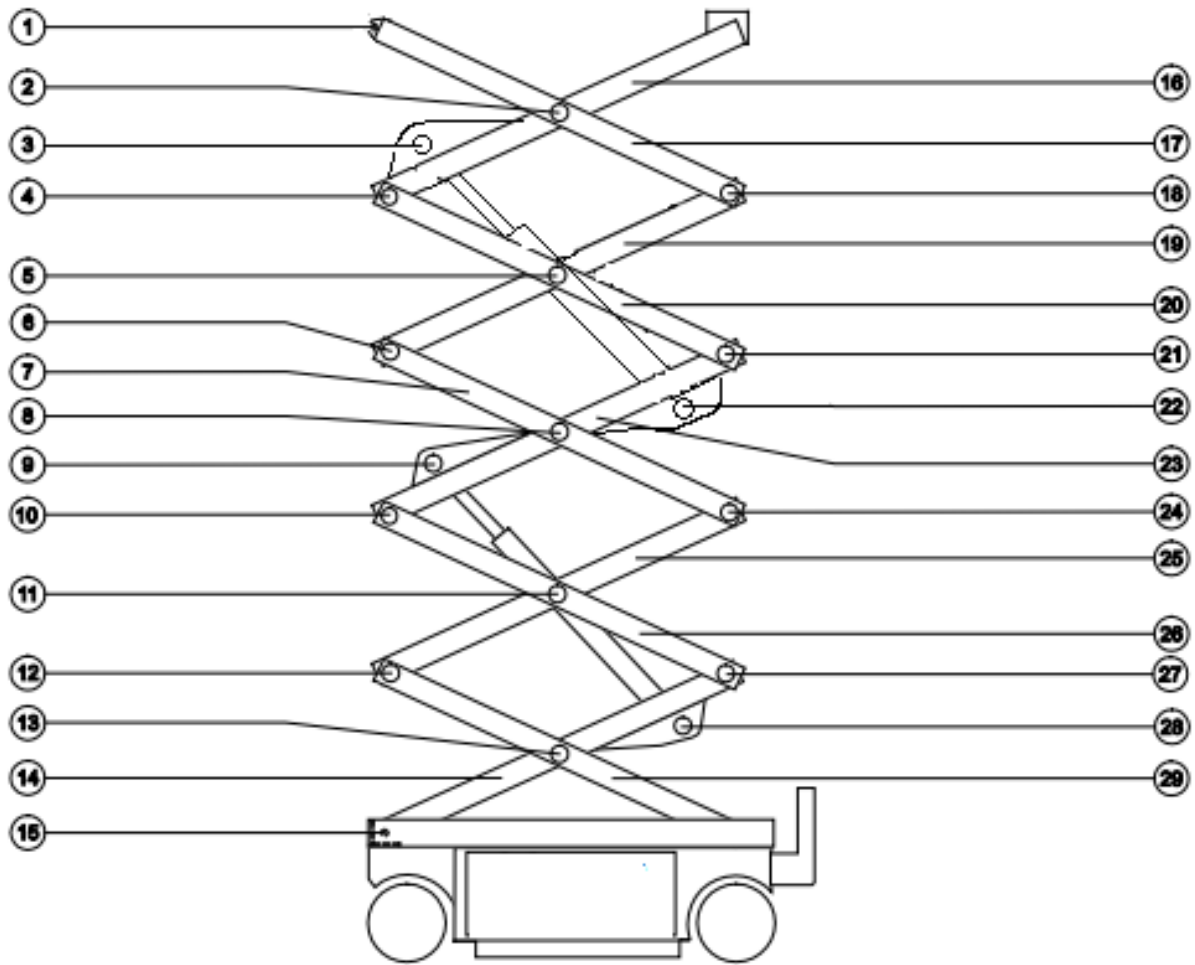

Fig. 4.44 Fifth layer fork assembly

- |                                      |                               |   |
|--------------------------------------|-------------------------------|---|
| 1. #6 pin                            | 11. #2 center pin             | 21. #4 pin (non-steering end)                 |
| 2. #5 center pin                     | 12. #2 pin (steering end)     | 22. Upper lift cylinder barrel end shaft      |
| 3. Upper lift cylinder rod end shaft | 13. No.1 center pin           | 23. #3 inner arm                              |
| 4. #5 pin (steering end)             | 14. #1 inner arm              | 24. #3 pin (non-steering end)                 |
| 5. #4 center pin                     | 15. #1 pin (steering end)     | 25. #2 inner arm                              |
| 6. #4 pin (steering end)             | 16. #5 inner arm              | 26. #2 outer arm                              |
| 7. #3 outer arm                      | 17. #5 outer arm              | 27. #2 pin (non-steering end)                 |
| 8. #3 center pin                     | 18. #5 pin (non-steering end) | 28. Lower lift cylinder barrel cylinder shaft |
| 9. Lower lift cylinder rod end shaft | 19. #4 inner arm              | 29. #1 outer arm                              |
| 10. #3 pin (steering end)            | 20. #4 outer arm              |   |



**WARNING:** danger of personal injury

This procedure requires specific maintenance skills, lifting equipment and a suitable workshop. Attempting this process without these skills and tools may result in death or serious injury, as well as serious component damage. It is strongly recommended to seek services from the dealer.



**CAUTION:** During removal of the hose

assembly or connector, the connector and the O-ring at the hose end must be replaced (if equipped). All connections must be tightened to the specified torque during installation. Please refer to the Specification for Selection of Tightening Torque of Lifting Platform.

1. Remove the platform.
2. Support and secure the access ladder to a suitable lifting device.

Remove the fasteners from the access ladder, and then remove the access ladder from the machine.

3. Remove cable harnesses from #5 outer arm wiring ring and #5 inner arm wiring plate and

set them aside.

4. Remove the fourth layer to fifth layer of boom wiring plate from the machine.
5. Attach the sling on the overhead crane to the #5 outer arm (No. 17).
6. Remove the securing fastener of #5 center pin (No. 2).
7. Knock out #5 center pin (No. 2) with a soft metal hammer and remove it from the machine.
8. Remove the securing fastener from the #5 pin (No. 18) at the non-steering end.
9. Remove #5 pin (No. 18) from the non-steering end of the machine using a soft metal hammer. Remove #5 outer arm (No. 17) from the machine.



**WARNING:** danger of personal injury

During removal of the #1 inner/outer arm from the machine, the inner/outer arm may become unbalanced and fall if not properly supported.

10. Mark, disconnect and plug the hydraulic hose on the upper lift cylinder. Cover the connector on the cylinder.

11. Mark and disconnect the harness of the cylinder valve block.
12. Attach the sling on the overhead crane to the upper lift cylinder rod end.
13. Remove the securing fastener from the upper lift cylinder rod end pin (No. 3).
14. Remove the upper lift cylinder rod end pin (No. 3) from the machine with a soft metal hammer.
15. Attach the sling on the overhead crane to #5 inner arm (No. 16).
16. Remove the securing fastener from pin 5 (No. 4) on the steering end of the machine.
17. Remove pin #5 (No. 18) from the steering end of the machine using a soft metal hammer. Remove #5 inner arm (No. 16) from the machine.
18. Connect the sling from the overhead crane to #4 outer arm (No. 20) on the ground control side.
19. Remove the securing fastener from the #4 center pin (No. 5) on the ground control side.
20. Remove the cable harness from the wiring plate of #4 inner arm and set it aside.
21. Remove wiring plate securing fastener of #4 inner arm and take off the 3<sup>rd</sup> layer to 4th layer of wiring plate.
22. Remove center pin #4 (No. 5) on the ground control side with a soft metal hammer.
23. Remove the securing fastener from the pin #4 (No. 21) at the non-steering end.
24. Remove #4 pin (No. 21) from the non-steering end of the machine by using a soft metal hammer. Remove #4 outer arm of ground control side (No. 20) from the machine.
25. Attach the sling on the overhead crane to the #4 outer arm on the battery side (No. 20).
26. Remove the securing fastener from the center pin #4 (No. 5) on the battery side. 58



**WARNING: Risk of crushing**

During removal of the cylinder rod end pin from the machine, the cylinder will fall if it is not properly supported.



**WARNING: danger of personal injury**

When the #4 outer arm is removed from the machine, if it is not properly supported, the #4 outer arm may become unbalanced and fall.

Pass a rod through the #4 center pin (No. 5) on the battery side and twist it to remove the pin. 59 Remove the #4 outer arm (No. 20) from the machine.

27. Use a soft metal hammer to remove the #4 center pin (No. 5) on the battery side.

28. Remove #4 outer arm (No. 20) from the machine.



WARNING: Risk of crushing

When the #4 outer arm is removed from the machine, it may become unbalanced and fall if the #4 outer arm is not properly supported.

29. Connect the sling from the overhead crane to #4 inner arm (No. 19).

30. Remove the securing fastener from pin 4 (No. 6) on the steering end of the machine.

31. Remove pin #4 (No. 6) from the steering end of the machine using a soft metal hammer. Remove #4 inner arm (No. 19) from the machine.



WARNING: Risk of crushing

When the #4 outer arm is removed from the machine, it may become unbalanced and fall if

the #4 outer arm is not properly supported.

32. Connect the overhead crane slings to the #3 outer arm (No. 7) on the ground control side and battery side respectively.

33. Remove the securing fastener from #3 center pin (No. 8).

34. Use a soft metal hammer to remove the center pin #3.

35. Remove the securing fastener from pin #3 (No. 24) at the non-steering end.

36. Use a soft metal hammer to remove pin #3 (No. 24) from the non-steering end of the machine. Remove the outer arms #3 (No. 7) on both sides of the machine respectively from the machine.

37. Remove the cable harness and hydraulic hose from the wiring plate and wiring ring of inner arm #3.

38. Remove the securing fastener of the second layer to third layer of boom wiring plate and remove the wiring plate.



WARNING: danger of personal

injury

When removing the #3 outer arm from the

machine, if it is not properly supported, the #3 outer arm may become unbalanced and fall.

39. Attach the sling on the overhead crane to the lug at the upper lift cylinder rod end.

40. Lift the lift cylinder to the vertical position.

41. Remove the securing fastener from the lift cylinder barrel end pin (No. 22). Remove the upper lift cylinder from the machine.



**WARNING: Risk of crushing**

When removing the cylinder barrel end pin from the machine, the cylinder will fall if it is not properly supported.



**CAUTION: Danger of component damage**

When removing the cylinder from the machine, be careful not to damage the valve or connector on the cylinder.

42. Attach the sling on the overhead crane to the lower lift cylinder rod end.

43. Remove the securing fastener from the lower lift cylinder rod end pin (No. 9).

44. Remove the lower lift cylinder rod end pin (No. 9) from the machine with a soft metal

hammer.

45. Place a 10×10×25 cm/3.94×3.94×9.84 inch cushion block on #1 inner arm cylinder plate (No. 14).



**WARNING: danger of personal injury**

When lowering the cylinder, do not touch the moving parts by hand.

46. Lower the cylinder onto the cushion block.

47. Connect the sling from the overhead crane to #3 inner arm.

48. Remove the securing fastener from #3 pin (No. 10) at the steering end of the machine.

49. Remove pin #3 (No. 10) from the steering end of the machine by using a soft metal hammer. Remove #3 inner arm (No. 23) from the machine.

50. Connect the overhead crane sling to the #2 outer arm (No. 26) on the ground control side and battery side respectively.

51. Remove the securing fastener from #2 center pin (No. 8) on both sides of the machine.

52. Remove #2 center pin on both sides of the machine with a soft metal hammer.

53. Remove the securing fastener from No. 2 pin (No. 27) at the non-steering end.

54. Use a soft metal hammer to remove the No. 2 pin (No. 27) from the non-steering end of the machine. Remove the #2 outer arm (No. 26) located on both sides of the machine from the machine.



**WARNING: Risk of crushing**

When the #2 outer arm is removed from the machine, if it is not properly supported, the #2 outer arm may become unbalanced and fall.

55. Remove the cable harnesses and hoses on the first layer to second layer of wiring plate, and lay them aside,

56. Remove the securing fastener of the first layer to second layer of wiring plate and remove the wiring plate.

57. Connect the sling on the overhead crane to #2 inner arm (No. 25). Lift the arm to the vertical position.

58. Remove #2 inner arm (No. 25) from the machine.

59. Remove No. 2 pin (No. 12) from the steering end of the machine with a soft metal

hammer. Remove #2 inner arm (No. 25) from the machine.

60. Remove the cable harness and hydraulic hose from the wiring ring of #1 inner arm.

61. Connect the sling on the overhead crane to the #1 inner arm (No. 14).

62. Raise the #1 inner arm (No. 14) 60cm/1.97ft.

63. Place a 10 cm/3.94 in × 10 cm/3.94 in × 1.2 m/3.94 ft long cushion block under #1 center pin (No. 13) across both sides of the chassis.

64. Lower the fork onto the cushion block placed on the chassis.



**WARNING: danger of personal injury**

When lowering the cylinder, do not touch the moving parts by hand.

65. Connect the sling on the overhead crane to the lower lift cylinder.

66. Mark, disconnect and plug the hydraulic hose on the lower lift cylinder. Cover the connector on the cylinder.



**WARNING: danger of personal injury**

Sprayed hydraulic oil can penetrate and

burn the skin. Loosen the hydraulic connectors very slowly to gradually dissipate the oil pressure.

Do not let the oil spray or jet.

67. Mark and disconnect the harness and hose on the cylinder valve.

68. Mark and disconnect the harness of the platform overload pressure sensor.

69. Lift the lift cylinder to the vertical position.

70. Remove the securing fastener from the lift cylinder barrel end pin (No. 28). Remove the pin with a soft metal hammer. Remove the lift cylinder from the machine.

71. Connect the sling on the overhead crane to the #1 inner arm (No. 14).

72. Rise the arm slightly and remove the cushion block.

73. Attach the sling on the overhead crane to #1 outer arm (No. 22). Do not apply any lifting force.

74. Remove outer snap ring and securing fastener from center pin #1 (No. 13).

75. Remove center pin #1 (No. 13) using soft metal hammer.

76. Slide #1 outer arm (No. 22) to the non-steering end and remove it from the

machine.

77. Connect the sling from the overhead crane to #1 inner arm (No. 10). Don't lift it.

78. Remove the travel switch protection cover plate securing fastener located at #1 inner arm and remove the travel switch protection cover plate from the machine.

79. Remove the lower/upper limit switch mounting plate fasteners, disconnect the limit switch connecting wire, and remove the lower/upper limit switch and the fixed mounting plate from the machine.

80. Remove the securing fastener of the pin securing #1 inner arm to the end of the chassis. Remove the pin.

81. Remove #1 inner arm (No. 10) from the machine.



WARNING: danger of personal injury

During removal of the #1 inner/outer arm from the machine, the inner/outer arm may become unbalanced and fall if not properly supported.



WARNING: danger of personal



injury

When removing the #1 inner/outer arm from the machine, make sure not to damage the limit switch.

#### 4.4 Installation of fifth layer fork (S3246 II , S3246E II)

##### 1. Installation of first layer fork

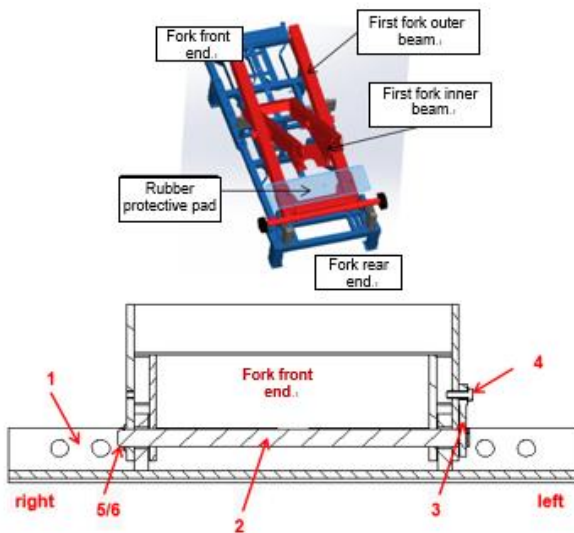

Fig. 4.45 Installation of lower mounting plate

1. Mounting plate assembly 2. Pin 3. Safety pin

4. Bolt 5. Washer 6. Retainer ring

- a) Place the part 1 to the front end of the fork installation trolley, pay attention to the placement direction (there are four mounting hole facing down);
- b) When the equipment from the hoisting fork outsourcing body to the fork part is loaded onto the trolley, as shown in Fig. 1, pay

attention to the placement direction of the fork; Confirm that the special sling is not damaged, the hoisting and mounting are firmly attached, and a safe distance is kept during hoisting;

- c) Lift the outer frames at both sides of the fork to both sides (except the first layer), pay attention to leaving the working distance and walking distance, and the workpiece shall not be placed on the ground;
- d) Adjust the position of the inner frame and part 1, and smash the shaft of part 2 into it. Note that the end of the shaft mounting circlip faces inward and smash into it from the left side of the fork;
 

Note that before installing the shaft, a proper amount of WD-40 lubrication anti-rust agent shall be sprayed on the contact surfaces at both ends of the shaft, and ED-40 shall be sprayed on the installation of the shaft at other positions in the subsequent fork;
- e) Insert the part 3 into the left end hole of the part 2, adjust the mounting hole of the part 3 to mounting hole the inner frame, and fix it

on the inner frame with a part 4;

- f) Assemble part 5 to the right end of part 2, and install part 6 into the end groove of part 2 with circlip pliers;

Note: the clearance between the washer and the plate after installation shall not exceed 2 mm/0.08 in;

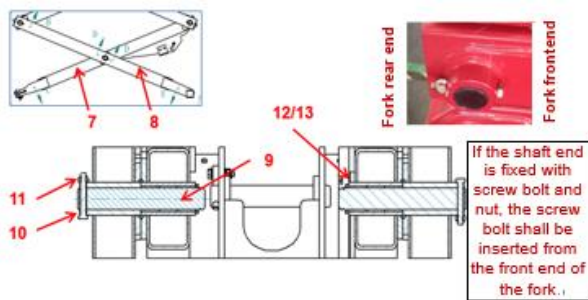

Fig. 4.46 Installation of first layer fork

7. First inner arm assembly 8. First outer arm welding 9. Pin 10. Bolt 11. Nut 12. Washer 13.

Retainer ring

- g) Adjust the positions of parts 7 and 8 to align the intermediate shaft holes, smash the shafts of part 3 on both sides respectively, and pay attention that the shaft installation circlip end faces inward;
- h) Thread part 10 into the outer hole of part 9, adjust part 10 to the outer frame shaft sleeve clamping hole, and install the part 11. Please note that the bolt fixed at the shaft end should be inserted from the front end of

the fork;

- i) Install part 12 into the inner side of the shaft of part 9 (two on each shaft), and then install part 13 into the groove of part 9 with the circlip pliers;
- j) Fastener 9/10, be careful not to pit the nut surface and other defects;

Tools: copper hammer, circlip pliers, open-ended wrench, electric wrench, socket

Tightening torque  $40 \pm 4$  N.m;

## 2. Lower lift cylinder lower assembly

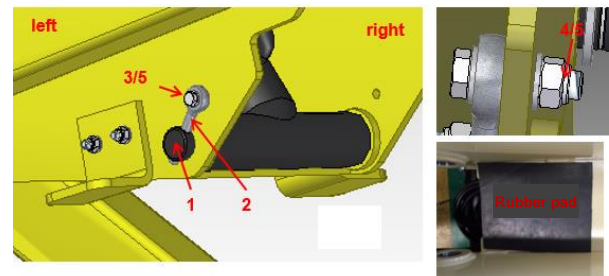

Fig. 4.47 Assembly of lower lift cylinder lower part

1. Shaft 2. Safety pin 3. Bolt 4. Nut 5. Washer

- a) Before placing the oil cylinder, lay a rubber pad at the rear end of the inner frame ear plate beam to avoid damaging the oil cylinder;
- b) Use the traveling crane to lower the oil cylinder to the rear end of the inner frame, adjust the position of the lower installation

position of the oil cylinder to make its mounting hole concentric with the mounting hole of the inner frame, and then smash the shaft of piece 1 into the shaft hole. Note that the hole end of the shaft faces outward, and smash it from the left side of the fork; Confirm that the special sling is not damaged, the hoisting and mounting are firmly attached, and a safe distance is kept during hoisting;

- c) Thread part 2 into the left end hole of part 1, adjust the mounting hole of part 2 to mounting hole the inner frame, fix it on the inner frame with part 3/4/5, and fasten it reliably;

Tools: rubber pad, copper hammer, special sling, open-ended wrench, electric wrench, socket

### 3. Installation of first layer pipeline



Fig. 4.48 Installation of first layer pipeline

- a) Pre-lay harness, cable and oil pipe: determine the connection positions of each harness, cable and oil pipe and pre-lay them on the right side of the inner frame of the first floor. Pay attention to the placement direction of each harness, cable and oil pipe. The harness and cable shall be placed at the lowest layer; The two oil pipes of the lower cylinder are connected to the elbow end, and the small joint end of the inlet pipe and the joint end of the return pipe of the upper cylinder are laid on the front end of the fork frame;
- b) Organize and smooth out each oil pipe, ensure that the two oil pipes connecting the lower oil cylinder are located on the left side (the return pipe is on the lower side, and the inlet pipe is on the upper side), and the two oil pipes connecting the upper oil cylinder are located on the right side (the return pipe is on the lower side, and the inlet pipe is on the upper side), fix the oil pipe to the mounting plate at the front end of the fork frame and fasten it;
- c) Continue to arrange the oil pipes backward

- from the first mounting plate along the right side of the inner frame, note that the oil pipes shall not cross, and then fix the oil pipe at the second and third mounting plates;
- d) Organize the oil pipe, harness and cables connected at the lower oil cylinder, and fix them at the upper and lower ends of the oil pipe hard pipe with strapping;
- e) Smooth the harness and pull-wire along the oil pipe. Note that each pull-wire of harness is located under the mounting plate. Use straps from the front of the fork to the end to fix each harness, pull-wire and oil pipe together on the round steel on the right side of the inner frame;
- f) Use straps to secure the upper and lower cylinders to connect the hose, and use a PVC sheath to wind the front oil pipe (without tangling harnesses, pull wires and PCU harnesses),
- g) Install one to two layers of wiring plate fittings (large width), smooth the oil pipe and wiring harness, and use the strapping strap to fix the fixed hole in the cable routing board according to Figure 1;

- h) Use a small strap to tie the PCU harness with the PVC sheath. Note that the PCU harness shall be on the right side of the PVC sheath and shall not be fixed on the upper and lower sides (to avoid crushing). The binding position shall be in the middle of the PVC arc.

4. Installation of second layer fork

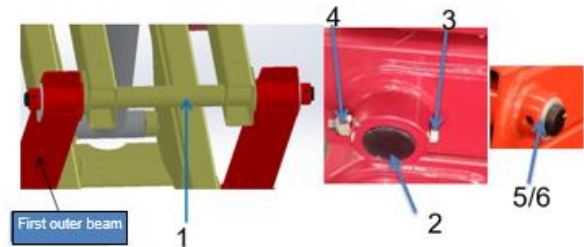

Fig. 4.49 Installation of second layer fork

- 1. Second inner arm assembly 2. Pin 3. Bolt 4. Nut 5. Washer 6. Retainer ring 7. Outer arm welding
- a) Push the inner frame material trolley to the position of the fork part installation trolley, raise the hydraulic lifting platform, place the second layer inner frame of part 1 to the upper side of the first layer inner frame, and pay attention to the placement direction (the one with fixing ring fixing hole is on the rear side);
- b) Adjust the front end of the first-layer outer

frame and the second-layer inner frame shaft hole concentric, and then smash part 2 in. Note that the end of the shaft mounting circlip faces inward, and smashes in from the left side of the fork;

- c) Thread the part 3 into the left hole of the part 2, adjust the part 3 to the clamping hole of the shaft sleeve of the outer frame, and install the part 4. Note that the bolt fixed at the shaft end should be inserted from the front end of the fork;
- d) Install part 5 into the right side of the shaft of part 2, and then install part 6 into the groove of part 2 with circlip pliers. Tighten parts 3/4 (tightening torque  $40 \text{ N.m} \pm 4 \text{ N.m}$ );

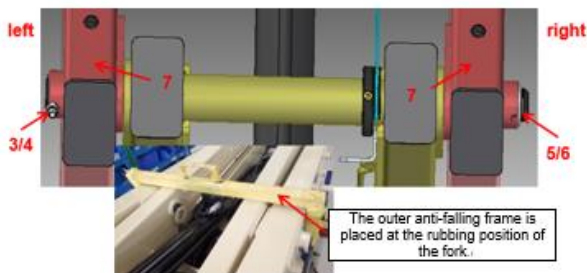

Fig. 4.50 Installation of second layer fork

1. Second inner arm assembly 2. Pin 3. Bolt 4. Nut 5. Washer 6. Retainer ring 7. Outer arm

welding

- e) Lift the outer frame of the second layer to both sides of the inner frame of the second

layer, and pay attention to the placement direction of the outer frame (with the mounting rubber plug hole facing upward, the subsequent third and fourth layers are the same as this requirement, and the outer frame of the fifth layer is left and right);

Note: when the outer frame is placed, it must be placed smoothly before the other side is lifted. After the outer frame is placed, the outer frame anti-falling tooling must be used and placed in the middle of the fork. Other subsequent layers shall follow this requirement;

- f) Adjust the second-layer outer frame concentric with the rear end shaft hole of the first-layer inner frame, and then smash the piece 2 in. Note that the end of the shaft mounting circlip faces inward and is smashed from the left side of the fork;

- g) Thread the part 3 into the left hole of the part 2, adjust the part 3 to the clamping hole of the shaft sleeve of the outer frame, and install the part 4. Note that the bolt fixed at the shaft end should be inserted from the front end of the fork;

- h) Install part 5 into the right side of the shaft of part 2, and then install part 6 into the groove of part 2 with circlip pliers. Tighten parts 3/4 (tightening torque  $40\pm 4\text{N.m}$ );

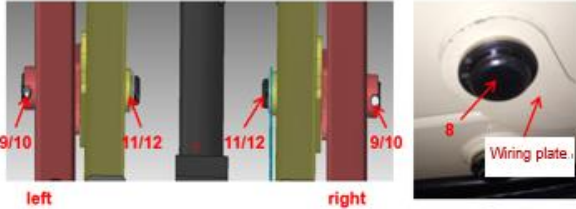

Fig. 4.51 Installation of second layer fork

8. Pin 9. Bolt 10. Nut 11. Washer 12. Retainer ring

- i) Adjust the position of the inner and outer frames of the second floor to align the intermediate shaft hole, smash the shaft of part 8 on both sides respectively, and note that the end of the shaft mounting snap ring faces inward;
- j) Insert the part 9 into the outer hole of the part 8, adjust the part 8 to the outer frame shaft sleeve clamping hole, and install the part 10. Note that the bolt fixed at the shaft end should be inserted from the front end of the fork;
- k) Install the wiring plate to the inner side of the right shaft, and then install the part 11 to the

inner side of the shaft of the part 8 (two for the left shaft and one for the right shaft). Then, install the part 12 into the groove of the part 8 with the circlip pliers;

- l) Tighten part 9/10 (tightening torque  $40\pm 4\text{N.m}$ );

Tools: copper hammer, circlip pliers, open-ended wrench, electric wrench, socket

5. Assembly of fork protective arm

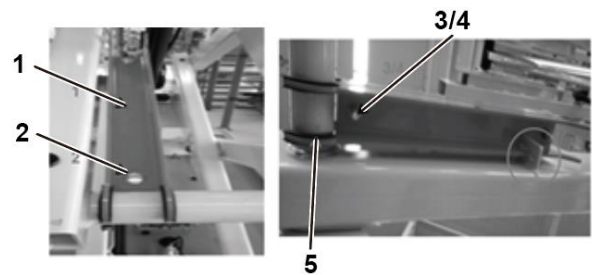

Fig. 4.52 Installation of fork protective arm

1. Assembly of bending plate 2. Bolt 3. Washer 4. Nut 5. fork protective arm

- a) Use part 2/3/4 to assemble the bending plate of part 1. At this time, nuts are not tightened by hand;
- b) Install the protective arm assembly to the front end of the second inner frame and then tighten it;
- c) Adjust the position of protective arm to move it to the right side of the inner frame front tube, and the movable end is clamped

on the support plate of the inner frame;

Tools: electric wrench, socket

6. Installation of second layer pipeline

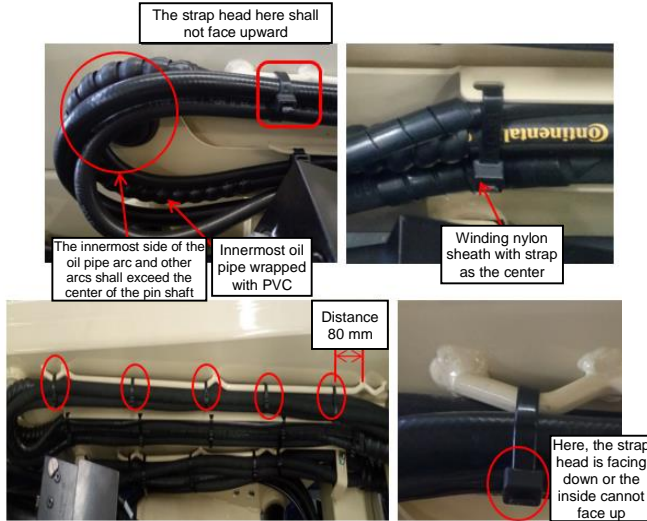

Fig. 4.53 Installation of second layer pipeline

- a) Lay the oil pipe and harness around the middle pin to the rear end of the fork according to Fig. 4.53, pass under the rear pipe of the second inner frame, and then fix the oil pipe and harness on the round steel of the inner frame;
- b) Smooth the rear end oil pipe and the harness of the fork and bypass the rear pipe of the second layer of inner frame, and spread along the right side of the inner frame to the front end of the fork; Use a nylon sheath to wrap the PCU harness here;
- c) Use a PVC sheath to wrap the oil pipe around the rear pipe of the second layer of

inner frame (without PCU harness), and then use insulating tape to fix the upper and lower ends of the PVC sheath for 3-4 laps;

- d) Install the two-to three-layer wiring plate assembly (with large width), smooth the oil pipe and harness, and fix it at the reserved fixing hole of the wiring plate with strapping;
- e) Use a small strap to tie the PCU harness with the PVC sheath (do not tie tightly, let the PCU harness can be moved). Note that the PCU harness shall be on the right side of the PVC sheath and shall not be fixed on the upper and lower sides (to avoid crushing).

7. Installation of third layer fork

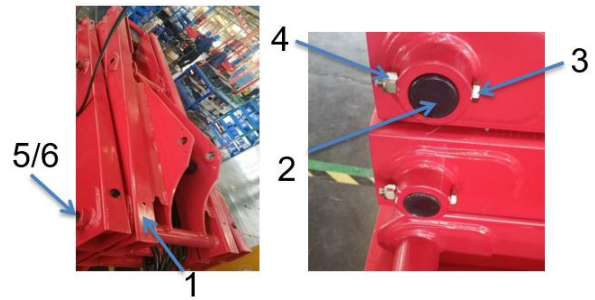

Fig. 4.54 Installation of third layer fork

1. Third inner arm assembly
2. Pin
3. Bolt
4. Nut
5. Washer
6. Retainer ring
7. Outer arm welding

- a) Push the inner frame material trolley to the position of the fork part installation trolley, raise the hydraulic lifting platform, place the

third-layer inner frame of part 1 to the upper side of the second-layer inner frame, and pay attention to the placement direction (the one with the fixing ring and fixing hole is on the rear side);

- b) Adjust the second-layer outer frame to be concentric with the front end shaft hole of the third-layer inner frame, and then smash part 2 in. Note that the end of the shaft mounting circlip faces inward and smash in from the left side of the fork;
- c) Thread the part 3 into the left hole of the part 2, adjust the part 3 to the clamping hole of the shaft sleeve of the outer frame, and install the part 4. Note that the bolt fixed at the shaft end should be inserted from the front end of the fork;
- d) Install part 5 into the right side of the shaft of part 2, and then install part 6 into the groove of part 2 with circlip pliers. Tighten parts 3/4 (reference torque 40 N.m±4 N.m);

Nut 5. Washer 6. Retainer ring 7. Outer arm welding

- e) Lift the part 7 three-layer outer frame to both sides of the three-layer inner frame;
- f) Adjust the three-layer outer frame concentric with the rear end shaft hole of the two-layer inner frame, and then smash the part 2 in. Note that the end of the circlip spring installed on the shaft is facing inward, and it is smashed in from the left side of the fork frame. When smashing the shaft, the opposite side needs to be protected by personnel to prevent the workpiece from falling;
- g) Thread the part 3 into the left hole of the part 2, adjust the part 3 to the clamping hole of the shaft sleeve of the outer frame, and install the part 4. Note that the bolt fixed at the shaft end should be inserted from the front end of the fork;
- h) Install part 5 into the right side of the shaft of part 2, and then install part 6 into the groove of part 2 with circlip pliers. Tighten parts 3/4 (reference torque 40 N.m±4 N.m);

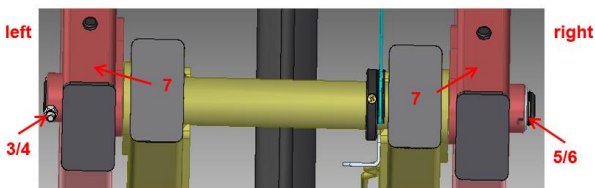

Fig. 4.55 Installation of third layer fork

1. Third inner arm assembly 2. Pin 3. Bolt 4.



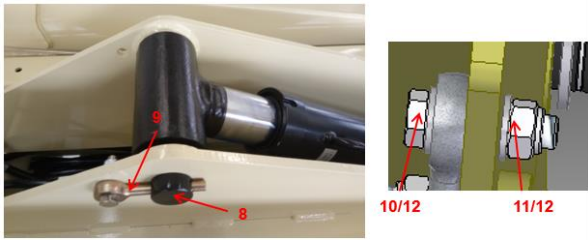

Fig. 4.56 Installation of third layer fork

8. Pin 9. Safety pin 10. Bolt 11. Nut 12.

Washer

- i) Lift the front end of the lower cylinder, adjust the front ear plate of the third inner frame to the hole, and then hit the axis of the part 8. Note that the end of the shaft hole is outward, and hit the left side of the fork frame.
- j) Insert the part 9 into the left end hole of the part 8, adjust the mounting hole of the part 9 to mounting hole the ear plate, and use the part 10/11/12 to fix it and fasten it reliably;
- k) Tighten the bleed plug on the upper part of the lower cylinder valve block;

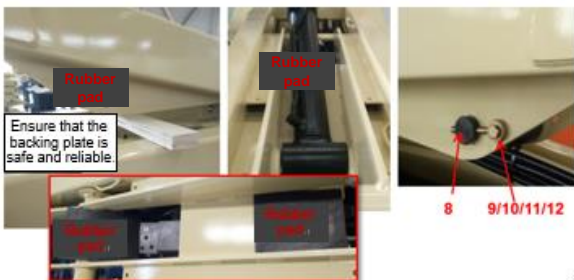

Fig. 4.57 Installation of third layer fork

8. Pin 9. Safety pin 10. Bolt 11. Nut 12. Washer

- l) Use traveling crane to lift the inner frame of the third layer, and support it on the lower backing plate. Pay attention to confirming that the backing plate is safe;
- m) Before placing the oil cylinder, put rubber blanket on the crossbeam of the lug at the rear-end of the inner frame and the middle circular tube to avoid damaging the oil cylinder; Hoist the upper oil cylinder to the rear end of the three-layer inner frame, adjust the position of the lower installation position of the oil cylinder to make its mounting hole concentric with the mounting hole of the inner frame, and then smash the shaft of part 8 into it. Note that the hole end of the shaft faces outward, and smash into it from the left side of the fork;
- n) Penetrate part 9 into the hole at the left end of part 8, adjust the mounting hole of part 9 to align the mounting hole at the inner frame, and use part 10/11/12 to fix it on the inner frame and fasten it reliably;
- o) Use the traveling crane to lift the rear tube of the third layer inner frame, take out the backing plate, and slowly lower the inner

frame, taking care not to press it to the wiring plate;

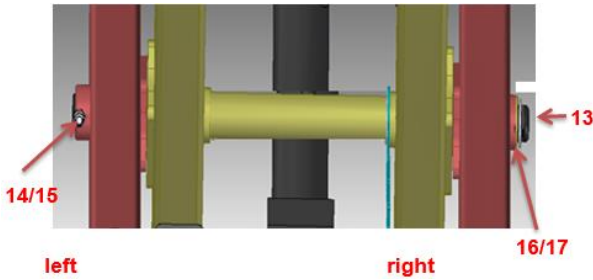

Fig. 4.58 Installation of third layer fork

13. Pin 14. Bolt 15. Nut 16. Washer 17.

Retainer ring

- p) Adjust the position of the third layer inner and outer frame to align the middle shaft hole, smash the part 13 shaft in, and pay attention to the shaft installation direction;
- q) Thread the part 14 into the outer hole of the part 13, adjust the part 14 to the outer frame shaft sleeve clamping hole, and install the part 15. Note that the bolt fixed at the shaft end should be inserted from the front end of the fork; Install the part 16 on the other side, and then install the part 17 into the groove of the part 13 with the circlip pliers.
- r) Fasten part 14/15.

Tools: copper hammer, circlip pliers, open-ended wrench, electric wrench, socket

Tightening torque of part 10:  $52 \pm 5$  N.m

Tightening torque of part 14/15:  $40 \pm 4$  N.m

### 8. Installation of third layer pipeline

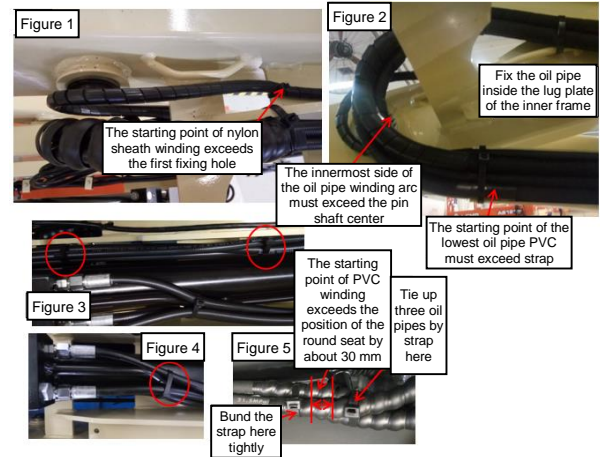

Figure 4.59 Installation of third layer pipeline

- a) Smooth the oil pipe and harness, keep the PCU harness to the far right, and then use nylon sheath to wind it. The upper winding starting point is as shown in Fig. 1 in Fig. 1.59, and the sheath length is about 550 mm/21.7 in;
- b) Confirm that the PVC sheath meets the requirements at each oil pipe winding position. Both ends shall be wound with insulating tape for 3-4 turns, and then the oil pipe shall be fixed with binding strap, as shown in Fig. 2 in Fig. 1.59; Pay attention to fix it on the two routing round steels of the inner side of the inner frame lug plate. The strap position is shown in fig. 3 in fig. 1.59;
- c) Fix the oil pipe connected by the upper oil

cylinder on the hard pipe of the upper oil cylinder with a strap. The positions are shown in fig. 4 and fig. 5 in fig. 1.59;

Note: before fixing the strap, wrap the PVC sheath on each oil pipe as shown in Fig. 5;

Each oil pipe must be fixed on the right side of the hard pipe of the oil cylinder, and cannot be fixed on the left side of the round seat at the rear end of the hard pipe;

d) Straighten the oil pipe and harness, and bypass the inner frame beam plate upward to the rear end of the fork;

e) Put the throat hoop at the oil return port at the upper end of the upper oil cylinder, connect the return pipe, put the throat hoop at the middle position between the hose end and the oil return port boss, and tighten the throat hoop. Fix the return pipe on the oil cylinder with a large strap;

Note that the clamping part of the oil pipe shall exceed the boss by at least 13 mm/0.51 in, and the direction of the throat hoop shall be horizontally outward after tightening;

f) Assemble the oil pipe to the lower left lower

joint of the upper cylinder valve block, fasten it with torque wrench, mark it with Mark pen;

g) Assemble the connection oil pipe to the lower right joint of the upper cylinder valve block, fasten it with torque wrench, and mark with a Mark pen;



Fig. 4.60 Installation of third layer pipeline

1. Fixing ring 2. Screw 3. Fixing ring 4. Screw

h) Fix the PCU harness with strap at the right fixing hole of the third layer inner frame as shown in Fig. 1 in Fig. 4.60, and spread the pipe to the front end of the fork by bypassing the inner frame;

i) Use part 2 to fix part 1 at the rear pipe of the third layer inner frame, and then use part 4 to fix part 3 on piece 1, as shown in Fig. 2 in Fig. 4.60.

9. Installation of fourth layer fork and wiring

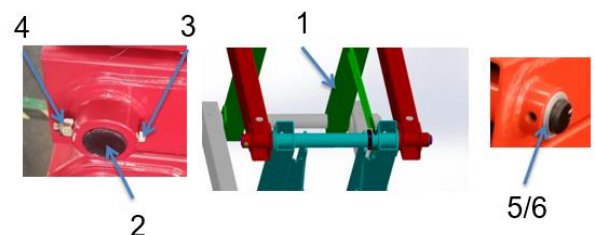

Figure 4.61 Installation of fourth layer fork

1. Fourth inner arm assembly 2. Pin 3. Bolt 4.  
Nut 5. Washer 6. Retainer ring 7. Outer arm

welding

- a) Push the inner frame material trolley to the position of the fork part installation trolley, raise the hydraulic lifting Platform, place the fourth layer inner frame of piece 1 on the upper side of the three-layer inner frame, and pay attention to the placement direction (there is a fixing ring on the rear side of the fixing hole);
- b) Adjust the three-layer outer frame to be concentric with the front end shaft hole of the four-layer inner frame, and then smash piece 2 in. Note that the end of the shaft mounting circlip faces inward and smash in from the left side of the fork;
- c) Thread the part 3 into the left hole of the part 2, adjust the part 3 to the clamping hole of the shaft sleeve of the outer frame, and install the part 4. Note that the bolt fixed at the shaft end should be inserted from the front end of the fork;
- d) Install part 5 into the right side of the shaft of part 2, and then install part 6 into the

groove of part 2 with circlip pliers. Tighten parts 3/4 (reference torque 40 N.m±4 N.m);

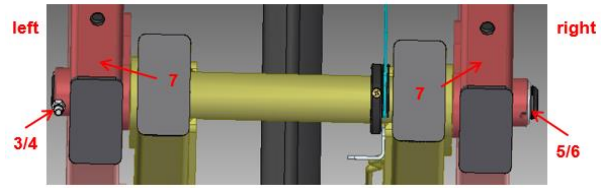

Figure 4.61 Installation of fourth layer fork

1. Fourth inner arm assembly 2. Pin 3. Bolt 4.  
Nut 5. Washer 6. Retainer ring 7. Outer arm

welding

- e) Lift the 7 four-layer outer frame to both sides of the four-layer inner frame;
- f) Thread the part 3 into the left hole of the part 2, adjust the part 3 to the clamping hole of the shaft sleeve of the outer frame, and install the part 4. Note that the bolt fixed at the shaft end should be inserted from the front end of the fork;
- g) Adjust the four-layer outer frame to be concentric with the shaft hole at the rear end of the three-layer inner frame, and then smash the part 2 in. Note that the end of the circlip spring installed on the shaft is facing inward, and it is smashed in from the left side of the fork frame. When smashing the shaft, the opposite side needs to be protected by personnel to prevent the

workpiece from falling;

- h) Install part 5 into the right side of the shaft of part 2, and then install part 6 into the groove of part 2 with circlip pliers. Tighten parts 3/4 (reference torque  $40 \text{ N.m} \pm 4 \text{ N.m}$ );

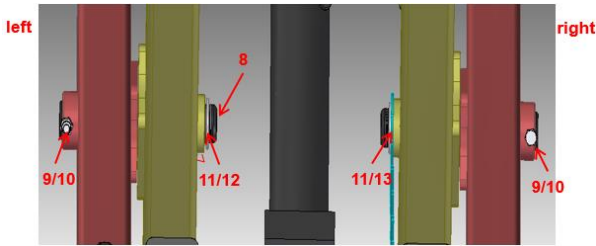

Fig. 4.62 Installation of fourth layer fork

8. Pin 9. Bolt 10. Nut 11. Washer 12. Retainer ring 13. Wiring plate

- i) Adjust the position of the four-layer inner and outer frame, align the middle shaft holes, smash the shaft of part 8 on both sides respectively, and pay attention to the shaft mounting circlip end facing inward;
- j) Insert part 9 into the outer hole of part 8, adjust the part 9 to the hole of the outer frame sleeve, and install part 10. Note that the bolts fixed at the shaft end must penetrate from the front end of the fork;
- k) Tighten the part 9/10 (reference torque  $40 \pm 4 \text{ N.m}$ )

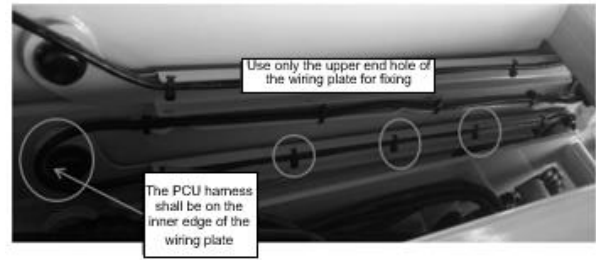

Fig. 4.63 Installation of fourth layer pipeline

- l) Install the three-to four-layer wiring plate assembly (with small width), install the rear end to the rear pipe of the third-layer inner frame, and install the front end to the inner side of the right shaft in the middle of the four-layer fork, then install the piece 11 into the inner side of the piece 8 (two for the left shaft and one for the right shaft), and install the piece 12 into the groove of the piece 8 with the circlip pliers;
- m) Fix the PCU harness at the upper hole of the wiring plate with a strap as shown in the figure, and pay attention to fixing with the upper hole only;  
  
Note that when fixing the PCU harness, make sure that it exceeds the fixing ring and leave a 10-15 mm/0.39-0.59 in gap between them;
- n) Lay the PCU harness around the wiring plate (PCU harness to be on the inside of

the wiring plate edge) to the rear of the fork and fix it on the wiring round steel on the right side of the fourth layer inner frame;

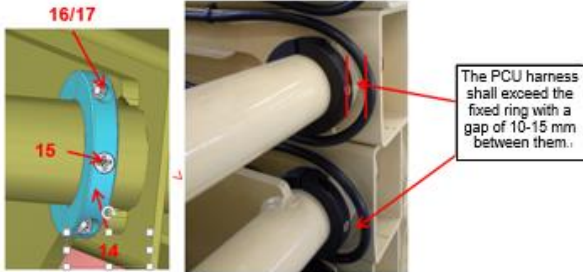

Fig. 4.64 Installation of fourth layer pipeline

15. Fastening ring 16. Screw 17. Fastening ring  
18. Screw

o) Use part 15 to fix part 14 at the rear pipe of the fourth layer inner frame, and then use piece 17 to fix piece 16 on piece 14, as shown in Figure 4.64;

p) Lay the PCU harness around the back pipe of the four-layer inner frame to the front end of the fork;

Note that when fixing the PCU harness, make sure that it exceeds the fixing ring and leave a 10-15 mm/0.39-0.59 in gap between them;

Tools: hydraulic lifting Platform, copper hammer, circlip pliers, open-ended wrench, electric wrench, socket

#### 10. Installation of fifth layer fork and wiring

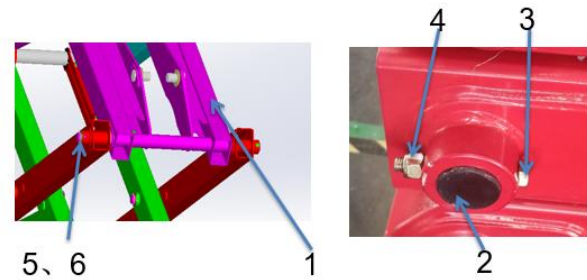

Fig. 4.65 Installation of fifth layer fork

1. Fifth inner arm assembly 2. Pin 3. Bolt 4. Nut  
5. Washer 6. Retainer ring

a) Push the inner frame material trolley to the position of the fork part installation trolley, raise the hydraulic lifting platform, place the part 1 fifth inner frame on the upper side of the four-layer inner frame, and pay attention to the placement direction (the one with the fixing ring fixing hole is on the rear side);

b) Adjust the four-layer outer frame and the front end shaft hole of the five-layer inner frame concentric, and then smash the piece 2 in, pay attention to the shaft mounting circlip end facing inward, smash in from the left side of the fork;

c) Thread the part 3 into the left hole of the part 2, adjust the part 3 to the clamping hole of the shaft sleeve of the outer frame, and install the part 4. Note that the bolt fixed at the shaft end should be inserted from the

front end of the fork;

- d) Install part 5 into the right side of the shaft of part 2, and then install part 6 into the groove of part 2 with circlip pliers. Tighten parts 3/4 (reference torque 40 N.m±4 N.m);
- e) Adjust the front end shaft hole of the four-layer inner frame and the five-layer outer frame to be concentric, and then smash piece 2 in. Note that the end of the shaft mounting circlip faces inward and smash in from the left side of the fork;
- f) Thread the part 3 into the left hole of the part 2, adjust the part 3 to the clamping hole of the shaft sleeve of the outer frame, and install the part 4. Note that the bolt fixed at the shaft end should be inserted from the front end of the fork;
- g) Install part 5 into the right side of the shaft of part 2, and then install part 6 into the groove of part 2 with circlip pliers. Tighten parts 3/4 (reference torque 40 N.m±4 N.m);

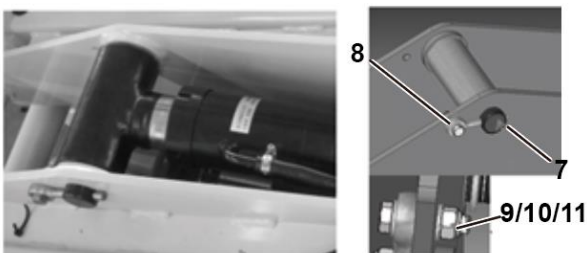

Fig. 4.66 Installation of fifth layer fork

- 7. Pin 8. Safety pin 9. Bolt 10. Nut 11. Washer
- h) Lift the front end of the upper oil cylinder, adjust the hole with the fifth inner frame front lug plate, and then smash the shaft of part 7. Note that the hole end of the shaft faces outward, and smash it from the left side of the fork;
- i) Insert the part 8 into the left end hole of the part 7, adjust the mounting hole of the part 8 to mounting hole the ear plate, and use the part 9/10/11 to fix it and fasten it reliably;
- j) Tighten the bleed plug on the upper part of the upper cylinder valve block;

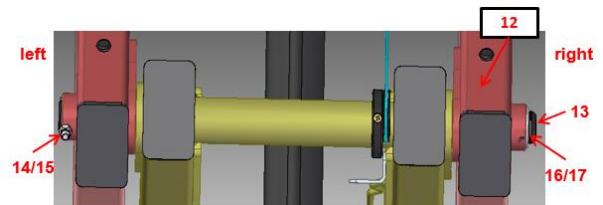

Fig. 4.67 Installation of fifth layer fork

- 12. Fifth outer arm assembly 13. Pin 14. Bolt 15. Nut 16. Washer 17. Retainer ring
- k) Lift the outer beam of part 12 to both sides of the five-layer inner frame;
- l) Adjust the fifth layer outer frame to be concentric with the rear end shaft hole of the fourth layer inner frame, and then knock part

13 into it. Note that the end of the circlip spring installed on the shaft is facing inward, and it is smashed in from the left side of the fork frame. When smashing the shaft, the opposite side needs to be protected by personnel to prevent the workpiece from falling;

- m) Insert part 14 into the left hole of part 13, adjust clip 14 of the front outer axle sleeve, install 15, and note that the bolts fixed at the shaft end must be penetrated from the front end of the fork frame.
- n) Install part 16 into the right side of the shaft of part 13, and then install part 17 into the groove of part 13 with circlip pliers. Tighten part 14/15 (refer to torque  $40\pm 4$  N.m);

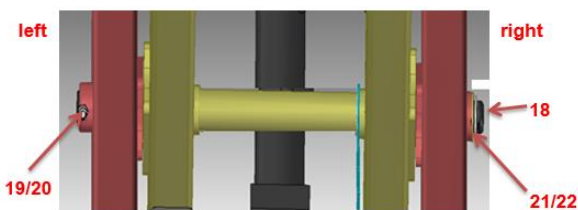

Fig. 4.68 Installation of fifth layer fork

18. Pin 19. Bolt 20. Nut 21. Washer 22.

Retainer ring

- o) Adjust the position of the five-layer inner and outer frame to align the middle shaft hole, smash the shaft of part 19 on both

sides respectively, and note that the circlip end of the shaft mounting faces inward;

- p) Insert the part 19 into the outer hole of the part 18, adjust the part 19 to the outer frame shaft sleeve clamping hole, and install the part 20. Note that the bolt fixed at the shaft end should be inserted from the front end of the fork; Install the part 21 on the other side, and then install the part 22 into the groove of the part 18 with circlip pliers;
- q) Tighten part 19/20 (reference torque  $40\pm 4$  N.m);

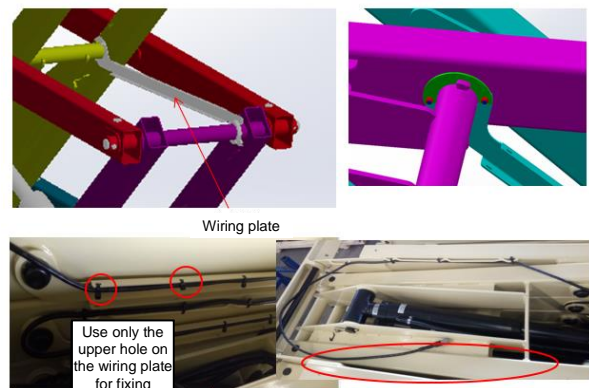

Fig. 4.69 Installation of fifth layer pipeline

- r) Install the four to five-layer wiring plate assembly, the rear end is installed at the rear pipe of the fourth layer inner frame, and the front end is installed at the inner side of the right side shaft in the middle of the five-layer fork, and then fix the wiring plate;
- s) Fix the PCU harness at the upper hole of the



wiring plate with a strap as shown in the figure, and pay attention to fixing with the upper hole only;

- t) Lay the front end of the PCU harness to the front end of the fork and fix it on the right side of the fifth-layer of outer frame. After fixing, place the wire harness on the fifth-layer fork (avoid landing).



Fig. 4.70 Slider Assembly

### 1. Slider

- u) Install part 1 slider to the rear end of the five-layer inner frame by using part 2. Note that the thick side of the slider faces downward when installing the lower layer Slider and when installing the upper layer slider, the thick side of the slider faces upward.

Tools: hydraulic lifting Platform, copper hammer, circlip pliers, open-ended wrench, electric wrench, socket

## 4.5 Removal of six-layer fork (S4046 II, S4046E II, S4650 II, S4650E II)

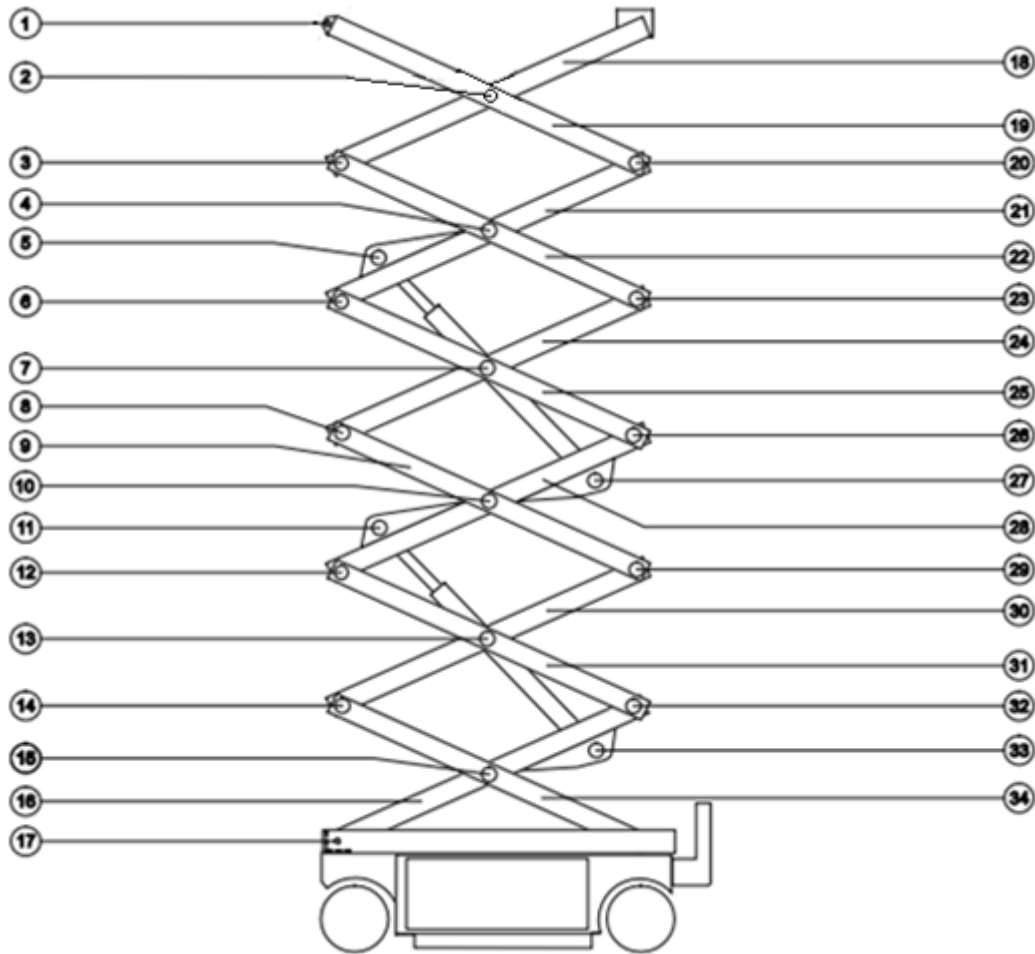

Fig. 4.71 Six-Layer Fork Assembly

- |                                       |                                  |   |
|---------------------------------------|----------------------------------|---|
| 1. Pin #7                             | 13. #2 center pin                | 24. #4 inner arm                              |
| 2. Center pin #6                      | 14. #2 pin (steering end)        | 25. #4 outer arm                              |
| 3. Pin #6 (steering end)              | 15. No.1 center pin              | 26. #4 pin (non-steering end)                 |
| 4. #5 center pin                      | 16. #1 inner arm                 | 27. Upper lift cylinder barrel end shaft      |
| 5. Upper lift cylinder rod end shaft  | 17. No. 1 pin (steering end)     | 28. #3 inner arm                              |
| 6. No. 5 pin (steering end)           | 18. Inner arm #6                 | 29. No. 3 pin (non-steering end)              |
| 7. No. 4 center pin                   | 19. Outer arm #6                 | 30. #2 inner arm                              |
| 8. No. 4 pin (steering end)           | 20. Pin #6 (non-steering end)    | 31. #2 outer arm                              |
| 9. #3 outer arm                       | 21. #5 inner arm                 | 32. No. 2 pin (non-steering end)              |
| 10. No. 3 center pin                  | 22. #5 outer arm                 | 33. Lower lift cylinder barrel cylinder shaft |
| 11. Lower lift cylinder rod end shaft | 23. No. 5 pin (non-steering end) | 34. #1 outer arm                              |
| 12. No. 3 pin (steering end)          |                                  |   |

 **WARNING:** danger of personal injury

This procedure requires specific maintenance skills, lifting equipment and a suitable workshop. Attempting this process without these skills and tools may result in death or serious injury, as well as serious component damage. It is strongly recommended to seek services from the dealer.

Note: During removal of the hose assembly or connector, the connector and the O-ring at the hose end must be replaced (if equipped). All connections must be tightened to the specified torque during installation. Please refer to the Specification for Selection of Tightening Torque of Lifting Platform.

1. Removal of platform;
2. Connect the sling on the overhead crane to #6 outer arm (No. 19).
3. Remove the cable harness on the 5th layer to 6th layer of boom wiring plate.
4. Remove the wiring plate fasteners and remove the 5th layer to 6th layer of boom wiring plate.
5. Remove the securing fastener from center pin 6 (No. 2) on the tank side and battery side respectively.
6. Remove center pin 6 on both sides with a soft metal hammer.
7. Remove the securing fastener from pin 6 (No. 20) at the non-steering end.
8. Remove pin #6 (No. 20) from the non-steering end of the machine by using a soft metal hammer.
9. Remove #6 outer arm (No. 19) from the machine.
10. Connect the sling on the overhead crane to #6 inner arm (No. 18). Lift the arm to the vertical position.
11. Remove the securing fasteners from the pin #6 (No. 3) at the steering end of the machine.

12. Remove the pin #6 (No. 3) from the steering end of the machine with a soft metal hammer. Remove the #6 inner arm (No. 18) from the machine.

 **WARNING:** danger of personal injury

When removing inner/#6 outer arm from the machine, the inner/outer arm may become unbalanced and fall if it is not properly supported.

13. Mark, disconnect and plug the hydraulic hose on the upper lift cylinder. Cover the connector on the cylinder.

 **WARNING:** danger of personal injury

Sprayed hydraulic oil can penetrate and burn the skin. Loosen the hydraulic connectors very slowly to gradually dissipate the oil pressure. Do not let the oil spray or jet.

14. Connect the sling from the overhead crane to the #5 outer arm of the tank side and the battery side respectively.
15. Remove the securing fastener from center pin #5 (No. 4).
16. Remove center pin #5 with a soft metal hammer.
17. Remove the securing fastener from the pin #5 (No. 23) at the non-steering end.
18. Remove the pin #5 from both sides of the machine with a soft metal hammer. Remove the #5 outer arms (No. 22) from both sides of the machine.

 **WARNING:** danger of personal injury

When removing inner/#6 outer arm from the machine, the inner/outer arm may become unbalanced and fall if it is not properly supported.

19. Mark and disconnect the harness hose from the cylinder valve block.
20. Connect the sling on the overhead crane to the upper lift cylinder rod end.

21. Remove the securing fastener from the pivot of the upper lift cylinder rod end (No. 5).
22. Remove the upper lift cylinder rod end pin (No. 5) from the machine using the soft metal hammer.
23. Connect the sling from the overhead crane to the #4 outer arm on the left and right sides of the machine.
24. Remove the securing fastener from the center pins No. 4 (No. 7) on both sides.
25. Remove the two center pins No. 4 with a soft metal hammer.
26. Remove the securing fastener from the pin #4 (No. 26) at the non-steering end.
27. Remove pin number 4 (No. 26) from the non-steering end of the machine with a soft metal hammer. Remove the #4 outer arms (No. 25) on both sides of the machine.
28. Remove the harness or hose from the wiring ring and the wiring plate of the #4 inner arm.
29. Remove the securing fastener of the wiring plate and remove the wiring plate from the machine.
30. Connect the sling on the overhead crane to the #4 inner arm (No. 24). Lift the arm to the vertical position.
31. Remove the securing fastener from pin #4 (No. 8) at the steering end of the machine.
32. Remove pin #4 (No. 8) from the steering end of the machine with a soft metal hammer. Remove the #4 inner arm (No. 24) from the machine.
33. Connect the lifting belt from the overhead crane to the #3 outer arm on the left and right sides of the machine.
34. Remove the securing fastener from the center pin shaft No. 3 (No. 10).
35. Remove the center pin #3 with a soft metal hammer.
36. Remove securing fastener from pin #3 (No. 29) at the non-steering end.
37. Remove pin #3 (No. 29) from the non-steering end of the machine using a soft gold hammer. Remove #3 outer arms (No. 9) on the left and right sides of the machine from the machine.
38. Connect the sling on the overhead crane to #3 inner arm (No. 28). Raise #3 inner arm and place a 10 cm/3.94 in × 10 cm/3.94 in × 1.2 m/3.94 ft cushion block on the connecting rod layer to access the cylinder barrel end pivot (index 27).
39. Mark, disconnect and plug the hoses and Harness on the upper lift cylinder and cover the connectors on the cylinder.
40. Connect the sling on the overhead crane to the upper lift cylinder rod end.
41. Lift the lifting cylinder to the vertical position.
42. Remove the upper lift cylinder barrel end pin (No. 27) from the machine with a soft metal hammer.
43. Remove the upper lift cylinder from the machine.

 **WARNING:** danger of personal injury

When the inner/#4 outer arm is being removed from the machine, it may become unbalanced and fall if it is not properly supported.

33. Connect the lifting belt from the overhead crane to the #3 outer arm on the left and right sides of the machine.

 **WARNING:** danger of personal injury

When removing the #3 outer arm from the machine, if it is not properly supported, the #3 outer arm may become unbalanced and fall.

38. Connect the sling on the overhead crane to #3 inner arm (No. 28). Raise #3 inner arm and place a 10 cm/3.94 in × 10 cm/3.94 in × 1.2 m/3.94 ft cushion block on the connecting rod layer to access the cylinder barrel end pivot (index 27).
39. Mark, disconnect and plug the hoses and Harness on the upper lift cylinder and cover the connectors on the cylinder.
40. Connect the sling on the overhead crane to the upper lift cylinder rod end.
41. Lift the lifting cylinder to the vertical position.
42. Remove the upper lift cylinder barrel end pin (No. 27) from the machine with a soft metal hammer.
43. Remove the upper lift cylinder from the machine.

 **WARNING:** danger of personal injury

The cylinder may become unbalanced and fall if it is not properly supported when the cylinder barrel end pivot is removed from the machine.

 **CAUTION:** Danger of component damage

When removing the cylinder from the

machine, be careful not to damage the valve or connector on the cylinder.

44. Connect the sling from the overhead crane to the #3 inner arm (No. 28). Raise the #3 inner arm and remove the stopper from the connecting rod.
45. Lower the #3 inner arm (No. 28) and remove the sling.
46. Attach the sling on the overhead crane to the lower lift cylinder rod end.
47. Remove the securing fastener from the lower lift cylinder rod end pin (No. 11).
48. Remove the lower lift cylinder rod end pin (No. 11) from the machine with a soft metal hammer.



**WARNING:** danger of personal injury

When removing the cylinder pin from the machine, the cylinder may fall if it is not properly supported.

49. Place a 10×10×25 cm/3.94×3.94×9.84 inch pad on inner arm cylinder plate No. 1 (No. 16).
50. Lower the cylinder onto the cushion block.
51. Remove the harnesses and hoses from the wiring ring and the wiring plate of #3 inner arm.
52. Remove the fasteners of wiring plate and remove the wiring plate from the machine.
53. Connect the sling on the overhead crane to #3 inner arm (No. 28). Lift the arm to the vertical position.
54. Remove the securing fastener from #3 pin (No. 12) at the steering end of the machine.
55. Remove #3 pin (No. 12) from the steering end of the machine using a soft metal hammer. Remove #3 inner arm (No. 28) from the machine.



**WARNING:** Risk of crushing

When removing the #3 inner arm from the machine, the #3 inner arm may become unbalanced and fall off if it is not properly supported.

56. Attach the sling on the overhead crane to the #2 outer arm on the left and right sides of the machine (Ser. No. 31).
57. Remove the securing fastener from center pin #2 (Ser. No. 13) on the left and right sides of the machine.
58. Remove center pin #2 with soft metal hammer.
59. Remove the securing fastener from pin #2 (No. 32) at the non-steering end.
60. Remove #2 pin (No. 32) from the non-steering end of the machine by using a soft metal hammer. Remove outer arms #2 (No. 31) on the left and right from the machine.
61. Remove the harness and hoses from the wiring plate and wiring ring of inner arm #2.
62. Remove the fasteners of wiring plate and remove the wiring plate from the machine.
63. Connect the sling on the overhead crane to inner arm #2 (No. 30). Lift the arm to the vertical position.
64. Remove the securing fastener from pin #2 (No. 14) at the steering end of the machine.
65. Remove Pivot No. 2 from the steering end of the machine using the soft metal hammer (index 14). Remove #2 inner arm (index 30) from the machine.



**WARNING:** Risk of crushing

When removing the #2 inner/outer arm from the machine, the #2 inner/outer arm may become unbalanced and fall if it is not properly supported.

66. Remove the harness and hydraulic hoses on the wiring ring of the #1 inner arm.

67. Connect the sling on the overhead crane to the #1 inner arm (No. 14).
68. Raise #1 inner arm 60 cm/23.6 in (No. 14).
69. Place a 10 cm/3.94 in × 10 cm/3.94 in × 1.2 m/3.94 ft long cushion block under #1 center pin (No. 13) across both sides of the chassis.
70. Lower the boom onto the pad placed on the chassis.



WARNING: danger of personal injury

When lowering the cylinder, do not touch the moving parts by hand.

71. Connect the sling on the overhead crane to the lower lift cylinder.
72. Mark, disconnect and plug the hydraulic hose on the lower lift cylinder. Cover the connector on the cylinder.



WARNING: danger of personal injury

Sprayed hydraulic oil can penetrate and burn the skin. Loosen the hydraulic connectors very slowly to gradually dissipate the oil pressure. Do not let the oil spray or jet.

73. Mark and disconnect the harness and hose on the cylinder valve.
74. Mark and disconnect the harness of the platform overload pressure sensor.
75. Lift the lift cylinder to the vertical position.
76. Remove the securing fastener from the lift cylinder barrel end pin (No. 28). Remove the pin with a soft metal hammer. Remove the lift cylinder from the machine.
77. Connect the sling on the overhead crane to the #1 inner arm (No. 14).
78. Rise the arm slightly and remove the cushion block.
79. Attach the sling on the overhead crane to #1 outer arm (No. 22). Do not apply any lifting force.

80. Remove outer snap ring and securing fastener from center pin #1 (No. 13).
81. Remove center pin #1 (No. 13) using soft metal hammer.
82. Slide #1 outer arm (No. 22) to the non-steering end and remove it from the machine.
83. Connect the sling from the overhead crane to #1 inner arm (No. 10). Don't lift it.
84. Remove the travel switch protection cover plate securing fastener located at inner arm #1 and remove the travel switch protection cover plate from the machine.
85. Remove the upper limit switch mounting plate fasteners, disconnect the limit switch connecting wire, and remove the upper limit switch and the fixed mounting plate from the machine.
86. Remove the securing fastener of the pin securing #1 inner arm to the end of the chassis. Remove the pin.
87. Remove #1 inner arm (No. 10) from the machine.



WARNING: danger of personal injury

During removal of the #1 inner/outer arm from the machine, the inner/outer arm may become unbalanced and fall if not properly supported.



WARNING: danger of personal injury

When removing the #1 inner/outer arm from the machine, make sure not to damage the limit switch.

## 4.6 Installation of sixth layer fork (S4046 II , S4046 E II , S4650 II , S4650 E II )

1. Installation of first layer fork

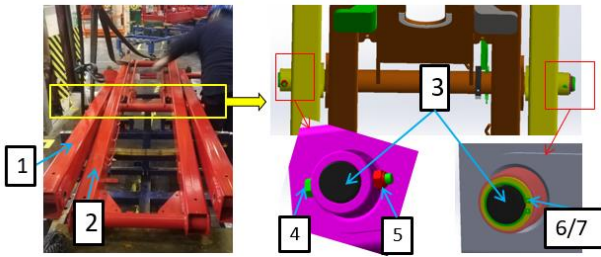

Fig. 4.72 Installation of first layer fork

1. First outer arm welding 2. First inner arm assembly 3. Pin 4. Bolt 5. Nut 6. Washer 7.

Retainer ring

- As shown in Fig. 4.72, place parts 1, 2 to the fork part and install the trolley, and pay attention to the placement direction;
- Adjust the positions of the inner frame and the outer beam of the one-layer to align the intermediate shaft hole, smash the shaft of part 3 from the left side of the fork, and note that the end of the shaft mounting snap ring faces inward;
- Insert the part 4 into the outer hole of the part 3, adjust it so that the pin through hole of the part 3 is concentric with the clamping hole of the outer beam shaft sleeve, and install the part 5. Note that the bolt fixed at the shaft end shall be inserted from the front end of the fork;
- Then install the part 6 into the end with circlip of the shaft 3; Then install the part 7 into the groove of the part 3 with circlip pliers;
- Tighten the part 4/5 with torque wrench; Note: use electric impact wrench to tighten the nut end, pay attention to the paint surface protection, and follow the requirements for nuts in other positions.

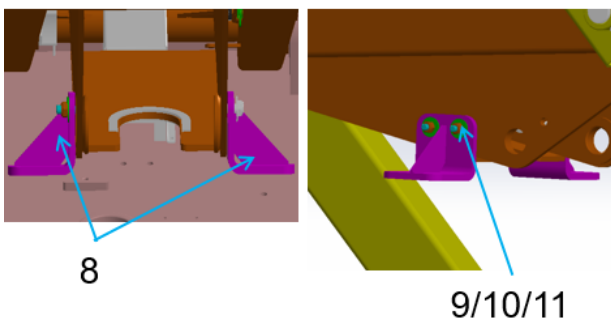

Fig. 4.73 Installation of first layer fork

- Press plate welding 9. Washer 10. Bolt 11. Nut
- f) Install the pressure plate of part 8 to both sides of the rear end of the inner frame, fix and tighten it with parts 9/10/11,

Note that the bolt should penetrate from the middle of the inner frame to both sides, and the washer and nut are on the outside.

Tools: fork single-layer spreader, copper hammer, circlip pliers, torque wrench, electric impact wrench, sleeve

Tightening torque of part 5:  $40 \pm 4$  N.m

2. Lower layer lift cylinder (lower end) assembly

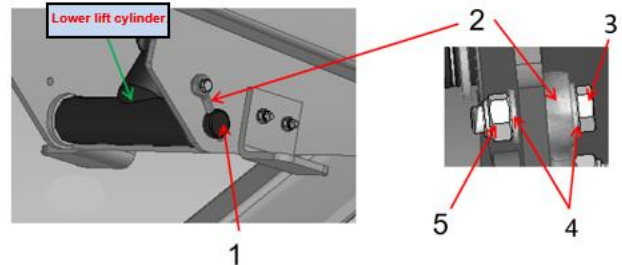

Fig. 4.74 Assembly of lower lift cylinder (lower end)

1. Pin 2. Safety pin 3. Bolt 4. Washer 5. Nut

- Before placing the oil cylinder, lay a rubber pad at the rear end of the inner frame ear plate beam to avoid damaging the oil cylinder;
- Use the traveling crane to lower the oil cylinder to the rear end of the inner frame, adjust the position of the lower installation position of the oil cylinder to make its mounting hole concentric with the mounting hole of the inner frame, and then smash the shaft of part 1 into the shaft hole. Note that the hole end of the shaft faces outward, and smash it from the right side of the fork;
- Confirm that the special sling is not damaged, the hoisting and mounting are firmly attached, and a safe distance is kept during hoisting;
- Put the piece 2 into the hole of the piece 1, adjust the mounting hole of the piece 2 mounting hole to align it to the lug plate of the

inner frame, and fix it with the piece 3/4/5 and fasten it reliably;

Tools: rubber pad, copper hammer, torque wrench, sleeve, electric impact wrench

Tightening torque of Part 3:  $52 \pm 5$  N.m

### 3. Installation of first layer pipeline

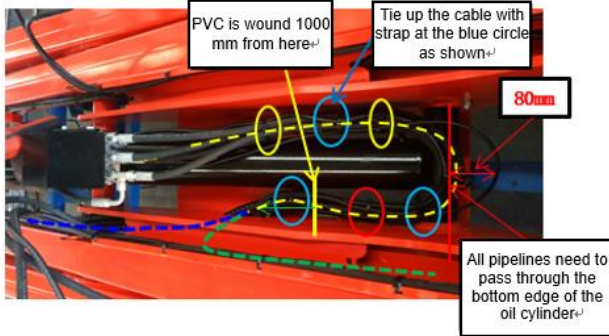

Fig. 4.75 Installation of first layer pipeline

- a) Smooth the oil pipe, harness and cable (each pipeline shall not be twisted and stressed), and bend the bottom end of the lower oil cylinder as shown by the yellow dotted line in Figure 4.75. The bending vertex shall pass through the outer edge of the bottom end of the oil cylinder (as shown by the red line in Figure 4.75), and then fix it on a layer of fork round steel of the inner frame (as shown by the red ring in Figure 4.75);
- b) Smooth the two oil pipes, cables and fork harness connecting the main valve on the oil tank side of the chassis;
- c) Smooth the two oil pipes, cable and fork harness connecting the main valve on the oil tank side of the chassis, pass them to the upper side of the middle shaft of the first-layer fork, and then bind them to the round steel on the inner wall;
- d) Connect the two Oil pipe and fork Harness of the upper cylinder assembly to the branch Harness of the cylinder valve block. The PCU harness and power Harness are bound with round steel along the right side of the fork (the other side of the Oil pipe).

### 4. Installation of second layer fork

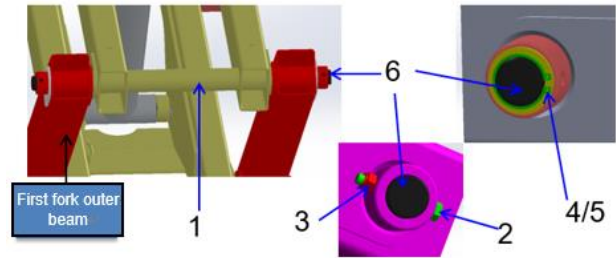

Fig. 4.76 Installation of second layer fork

1. Second inner arm assembly 2. Bolt 3. Nut 4. Retainer ring 5. Washer 6. Pin

- a) Push the inner frame material trolley to the position of the fork component assembly trolley, raise the hydraulic lifting platform, place the inner frame of the second-layer fork of part 1 to the upper side of the inner frame of the first-layer fork, and pay attention to the placement direction;
- b) Adjust the outer beam of the first-layer fork to be concentric with the front end shaft hole of the second-layer fork inner frame, and then knock part 6 in. Note that the end of the shaft mounting circlip faces inward and knock in from the left side of the fork;
- c) Thread the part 2 into the through hole 6, adjust the pin 6 so that the through hole is concentric with the bolt hole of the outer beam shaft sleeve, and install the parts 2 and 3. Note that the bolt fixed at the shaft end shall be inserted from the front end of the fork; Tighten the part 2/3;
- d) Install part 5 into the end of the shaft circlip of part 6 and install part 4 in the groove of part 6 with circlip pliers.

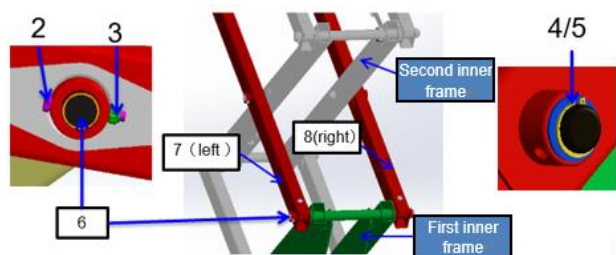

Figure 4.77 Installation of second layer fork



- 2. Bolt 3. Nut 4. Retainer ring 5. Washer 6. Pin
- 7. Left welding of the second outer arm 8. Right welding of the second outer arm
- e) Lift and place parts 7 and 8 to the two sides of the inner frame of the second floor separately, pay attention to the direction of placement of the outer beam (there are rubber plug holes facing up), and pay attention to distinguish the left and right;
- Note: when the outer beam is placed, it must be placed steadily before the other side is lifted. After the outer beam is placed, the outer beam anti-falling tooling must be used and placed in the middle of the fork. Other subsequent layers shall follow this requirement;
- f) Adjust the second-layer outer beam of part 7 and part 8 to be concentric with the rear end shaft hole of the first-layer inner frame, and then knock part 6 into it. Note that the end of the shaft mounting circlip faces inward and is smashed from the left side of the fork;
- g) Thread part 2 into the left hole of part 6, adjust the pin through hole so that it is concentric with the bolt hole of the outer beam shaft sleeve, and install the parts 2 and 3. Note that the bolt fixed at the shaft end shall be inserted from the front end of the fork; Tighten the part 2/3;
- h) Install part 5 into the side of the shaft circlip of the part 6, then install part 4 in the groove of Part 6 with circlip pliers.

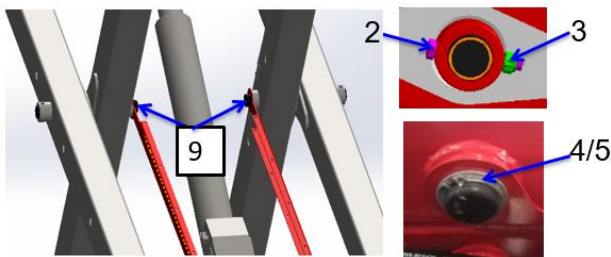

Fig. 4.78 Installation of second layer fork

- 2. Bolt 3. Nut 4. Retainer ring 5. Washer 9. Pin

- i) Adjust the position of the inner frame and the outer beam of the second layer to align the middle shaft hole, smash the shaft of part 6 on both sides respectively, and pay attention to the shaft mounting circlip end facing inward;
- j) Thread the piece 2 into the through hole of the piece 9, adjust so that the pin through hole is concentric with the bolt hole of the outer beam shaft sleeve, and install the pieces 2 and 3. Note that the bolt fixed at the shaft end shall be threaded from the front end of the fork;
- k) Then install the piece 5 into the end side of the circlip of the shaft 9 (one for each of the two pin circlip ends), and then install the Part 4 into the groove of the piece 9 with circlip pliers;
- l) Tighten the part 2/3; Tightening torque:  $40 \pm 4$  N.m.

Tools: fork single-layer hanger, copper hammer, sleeve, torque wrench, electric impact wrench, circlip pliers

#### 5. Installation of second layer pipeline

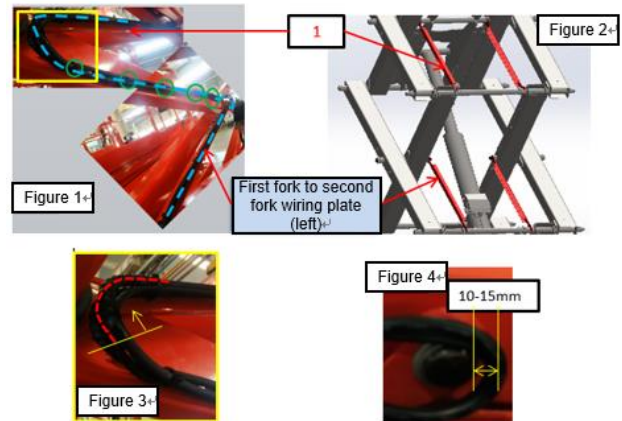

Fig. 4.79 Installation of second layer pipeline

#### 1. Wiring plate assembly

- a) Smooth the inlet, return pipes and branch harness of the upper oil cylinder connected with fork harness, following the light blue dotted line shown in Fig. 4.79 of Fig. 1, and bind it to the inner wall of the second-layer fork. The key control points are as follows:

- The inlet, return pipe and fork harness of the upper oil cylinder are connected to the branch wire harness of the oil cylinder to arc along the central axis, and the distance between the top of the arc of all pipelines and the top of the arc of the pin of the fork frame is 10-15 mm (as shown in Fig. 4.79 of Fig. 4);
- The inlet, return pipes and fork harness of the upper oil cylinder shall be smoothed and connected to the branch harness of the upper oil cylinder, and shall be bound to the round steel of the second-layer inner arm line, turn on the inner side of the fork shaft, and be bound to part 1. The pipeline distance between the two binding points around the bend shall be 490 mm-510 mm;
- As shown in Fig. 4.79, the yellow line position in Fig. 3 starts to wind 300mmPVC, and protects it to the starting end point of the wiring plate. As shown by the dotted line red Fig. 3, the two ends are wound and fixed with adhesive tape.
- When the pipeline is bundled on the wiring plate, only the side fixing holes on the wiring plate are used for bundling.
- When the retaining ring is assembled, the opening direction is from the front end of the whole machine to the back end;

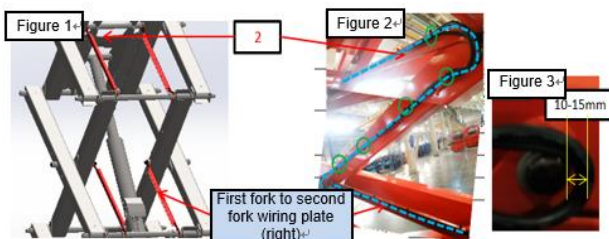

Fig. 4.80 Installation of second layer pipeline

## 2. Wiring plate assembly

- b) Smooth the PCU harness and route

according to the light blue dotted line shown in Figure 2, and bypass the central axis of the second-floor fork and bind it to the inner wall of the second-floor fork. The wiring of the power cables is exactly the same as that of the PCU. The key control points are as follows:

- The PCU harness arcs along the central axis of the fork, and the distance between the top of all pipeline arcs and the arc top of the fork pin is 10-15 mm/0.59 in (as shown in Fig. 3);
- Smooth the PCU harness, bind it to the two-layer inner arm routing round steel, turn on the inner side of the fork shaft, bind it to the fixing hole at the upper end of the wiring plate of part 2, and the PCU contacts the fork round tube around the arc top point and deviates from the fixing ring by 2 mm/0.08 in;
- When bundling the harness at the wiring plate, only use the upper fixing hole on the wiring board to fix it;
- When the PCU harness and power harness are wound around the arc, tie them with a small strap at the position shown in the yellow circle in Fig. 2.
- When the retaining ring is assembled, the opening direction is from the front end of the whole machine to the back end;

6. Installation of second layer fork (safety support)

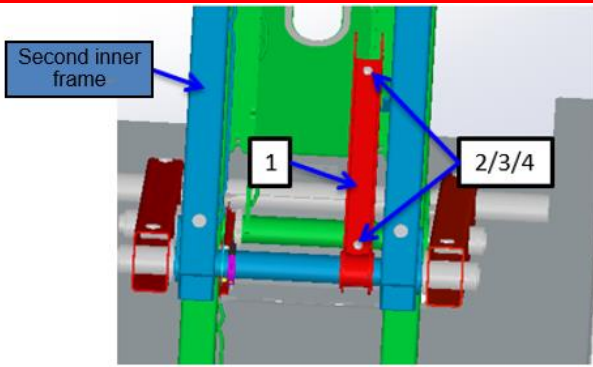

Fig. 4.81 Installation of second layer fork (safety support)

1. Assembly of bending plate 2. Bolt 3. Washer 4. Nut

- Install the protective arm assembly on the second-layer fork;
- Use part 2/3/4 to assemble the bending plate of part 1. At this time, nuts are not tightened by hand;
- Install the protective arm fitting to the front end of the second inner frame, and then tighten the nut;
- Adjust the position of protective arm to move it to the right side of the inner frame front tube, and the movable end is clamped on the support plate of the inner frame;

Tools: sleeve, electric impact wrench, torque wrench

Part 4 tightening torque  $52 \text{ N.m} \pm 5 \text{ N.m}$

### 7. Installation of third layer fork

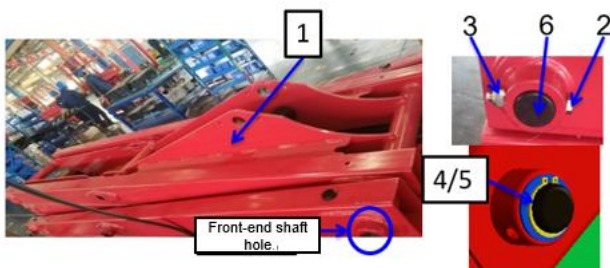

Fig. 4.82 Installation of third layer fork

1. Third inner arm assembly 2. Bolt 3. Nut 4. Retainer ring 5. Washer 6. Pin

- Push the inner frame material trolley to the position of the fork part-mounted trolley, raise the hydraulic lifting platform, place the second

layer inner frame of part 1 to the upper side of the second layer inner frame, and pay attention to the direction;

- Adjust the second-layer outer beam to be concentric with the front end Shaft hole of the three-layer inner frame, and then smash the Part 4 in. Note that the end of the shaft mounting circlip faces inward, and smash in from the left side of the fork;
- Thread the part 2 into the through hole 6, adjust the pin 6 so that the through hole is concentric with the bolt hole of the outer beam shaft sleeve, and install the parts 2 and 3. Note that the bolt fixed at the shaft end shall be inserted from the front end of the fork; Tighten part 2/3
- Install the piece 5 into the end of the shaft circlip of the piece 6, and then install the Part 4 into the groove of the piece 6 with a circlip pliers;

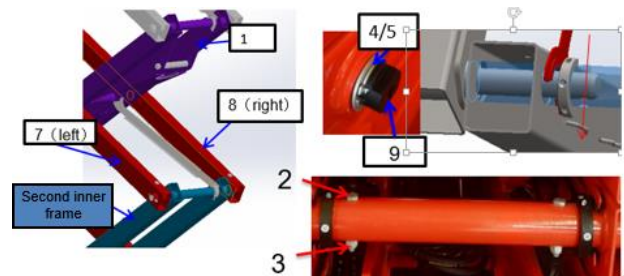

Fig. 4.83 Installation of third layer fork

1. Third inner arm assembly 2. Bolt 3. Nut 4. Retainer ring 5. Washer 6. Pin 7. Third outer arm left assembly 8. Third outer arm right assembly 9. Shaft

- Lift and place the two three-layer outer beams of parts 7 and 8 to both sides of the three-layer inner frame, and pay attention to the placement direction of the outer beam (with the mounting rubber plug hole facing upward, the outer beam is divided to left and right);

Note: when the outer beam is placed, it must be placed steadily before the other side is lifted. After the outer beam is placed, the

outer beam anti-falling tooling must be used and placed in the middle of the fork. Other subsequent layers shall follow this requirement;

- f) The three-layer outer beam of adjusting part 7 and part 8 is concentric with the rear end shaft hole of the two-layer inner frame, and then the part 9 is smashed in from both sides of the fork. Note that the end of the shaft mounting circlip is outside, and it is smashed from both sides of the fork;
- g) Install the part 5 into the end of the shaft circlip of the part 9 and install the part 4 in the groove of the part 9 with a circlip pliers.
- h) Use a flexible wrench to adjust the pin of the part 9 so that its through hole is concentric with the bolt fixing hole of the second-layer inner frame tube, and insert the part 2 into the hole of the second-layer inner frame tube and the hole of the part 9, and install the part 3. Note that the fixed bolt of the shaft end shall be inserted from top to bottom; Tighten the part 2/3;

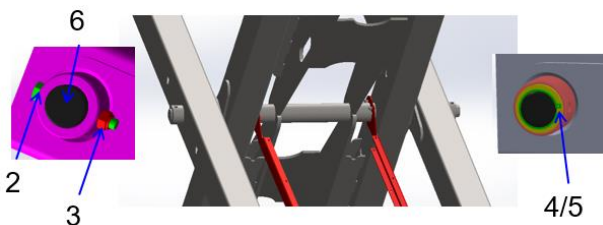

Fig. 4.84 Installation of third layer fork

2. Bolt 3. Nut 4. Retainer ring 5. Washer 6. Pin

- i) Adjust the position of the third-layer inner frame and the third-layer outer beam to align the middle shaft hole, smash the shaft of part 6 from the left side of the fork, and pay attention to the shaft mounting circlip end facing inward;
- j) Thread the piece 2 into the outer hole of the piece 6, adjust the fitting holes of the shaft sleeve of the outer beam of the piece 6, and install the pieces 2 and 3. Note that the bolt

fixed at the shaft end shall be inserted from the front end of the fork; Tighten the part 2/3;

- k) Then install the part 5 into the end side of the part 6 shaft circlip; Then install the part 4 into the groove of part 6 with a circlip pliers;

Tools: fork single-layer hanger, copper hammer, socket, torque wrench, electric impact wrench, circlip pliers, flexible wrench

Tightening torque of part 3:  $40 \pm 4$  N.m

#### 8. Installation of third layer fork (wiring plate)

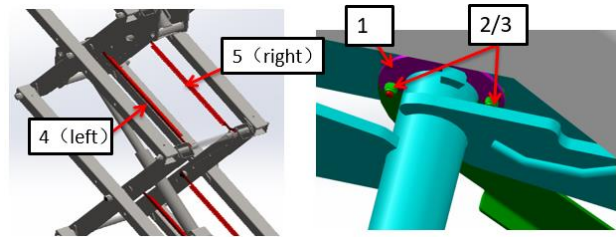

Fig. 4.85 Installation of third layer fork (wiring plate)

1. Arc plate 2. Nut 3. Bolt 4. Wiring plate assembly 5. Wiring plate assembly

- a) Fix Part 1 and Part 4 on the left middle shaft with Part 2 and Part 3, tighten them with the ratchet wrench, and mark them with Mark pen;
- b) Fix part 1 and 5 on the right middle shaft with part 2 and 3, tighten them with a ratchet wrench, and mark them with Mark pen;

Tool: ratchet wrench

#### 9. Installation of third layer lower cylinder (upper end)

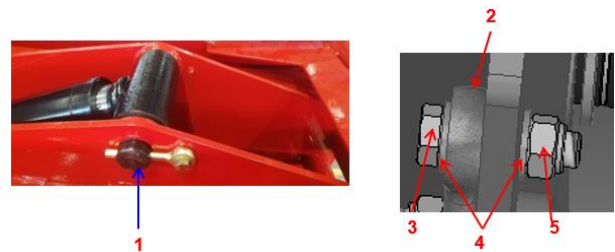

Fig. 4.86 Installation of third layer lower cylinder (upper end)

1. Pin 2. Safety pin 3. Bolt 4. Washer 5. Nut

- a) Lift the front end of the lower cylinder, adjust it to align its hole with the hole of the front side ear plate of the third layer inner frame, and

then smash the shaft of piece 1 into the hole. Note that the hole end of the shaft faces outward, and smash it into the hole from the right side of the fork;

- b) Insert the part 2 into the through hole of the part 1, adjust the mounting hole of the part 2 to mounting hole the ear plate, fix it with the part 3/4/5, tighten to specified torque and draw the mark MARK;

Tools: copper hammer, torque wrench, sleeve and electric impact wrench

Tightening torque of Part 3:  $52 \pm 5$  N.m

10. Installation of third layer upper cylinder (lower end)

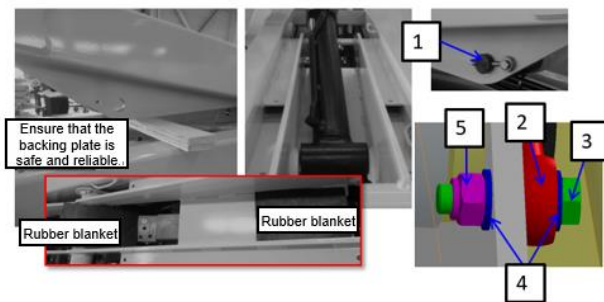

Fig. 4.87 Installation of third layer upper cylinder (lower end)

- 1. Pin 2. Safety pin 3. Bolt 4. Washer 5. Nut

- a) Use traveling crane to lift the inner frame of the third layer, and support it on the lower backing plate. Pay attention to confirming that the backing plate is safe; Be careful not to press the wiring plate
- b) Before placing the oil cylinder, put rubber blanket on the crossbeam of the lug at the rear-end of the inner frame and the middle circular tube to avoid damaging the oil cylinder; Hoist the upper oil cylinder assembly to the rear end of the three-layer inner frame, adjust the position of the lower installation position of the oil cylinder to make its mounting hole concentric with the mounting hole of the inner frame, and then smash the shaft 7 in. Note that the hole end

of the shaft faces outwards, and smash it from the right side of the fork;

- c) Insert the part 2 into the through hole of the part 1, adjust the mounting hole of the part 2 to mounting hole the ear plate, fix it with the part 3/4/5, tighten to specified torque and draw the mark MARK;
- d) Lift the rear tube of the third-layer inner frame, take out the backing plate, and slowly lower the inner frame.

Tools: fork single-layer hanger, copper hammer, torque wrench, sleeve, electric impact wrench

Tightening torque of Part 3:  $52 \pm 5$  N.m

11. Installation of third layer pipeline

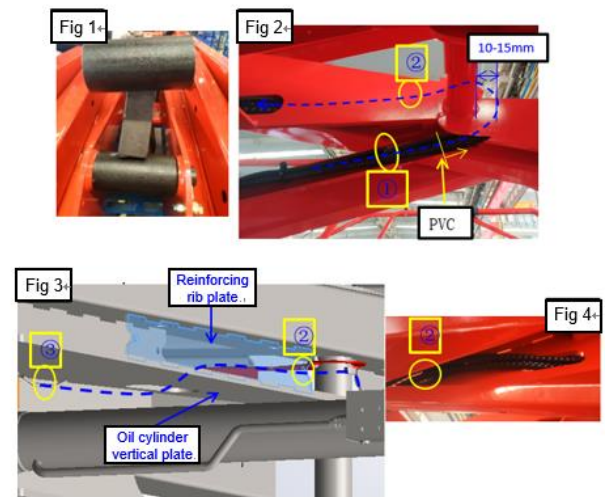

Fig. 4.89 Installation of third layer pipeline

- a) Get the oil pipe and harness connecting the upper oil cylinder straight (all positions shall not be crossed), arc along the middle axis of the three-layer inner beam from the wiring plate as shown by the blue dotted line in Fig. 2 of Fig. 4.89, and bind it to the three-layer fork. The key control points are as follows:
  - Connect the two oil pipes and fork harness connecting upper cylinder valve block branch harness of the upper oil cylinder assembly. After bending along the middle shaft pipe of the three-layer fork, enter the lower side of the reinforcing rib plate, and follow the blue

dotted line arrow in Fig. 2. All pipeline is bound to the round hole of the reinforcing rib plate, as shown in Fig. 3 ②. The pipeline is not allowed to be staggered;

- Connect the two oil pipes of the upper oil cylinder as shown in the yellow line position in Fig. 2, and respectively wrap with 1500 mm/59 in long PVC;
- Smooth and connect the upper oil cylinder oil pipe and harness (all positions shall not be crossed), pass through the vertical plate routing hole of the oil cylinder (as shown in Fig. 4) as shown in the blue dotted line in Fig. 3, install it from the outside to the inside, and bind it at the position ② as shown in Fig. 3;



Fig. 4.90 Installation of third layer pipeline

- b) Smooth the oil pipe and harness of the upper cylinder (all positions shall not be crossed), and route the line as shown in Fig. 4.90. The key control points are as follows:

- The oil inlet pipe of the upper cylinder is routed as shown by the yellow dotted line in the figure;
- The upper cylinder return pipe is routed as shown by the green dotted line in the figure with the front end bound to the cylinder;
- Connect the fork harness with the branch harness of the upper cylinder valve block, and connect the coil of the upper cylinder valve block reversing valve. After confirming that the connection is firm, draw a MARK sign. Then fold the extra

harness back and bind it to the cylinder;

- c) Remove the guard plug of oil pipe (4120703652) and the protective cap of straight fitting (4120001799) of the upper cylinder, screw the oil pipe into the joint, tighten it to specified torque, and apply identification glue;
- d) Connect the return pipe of the upper oil cylinder and assemble it on the oil return hole joint of the upper oil cylinder, and note that the joint direction is parallel to the oil cylinder;

Note: tighten the oil pipe joints with torque wrench and apply marking adhesive.

## 12. Installation of fourth layer fork

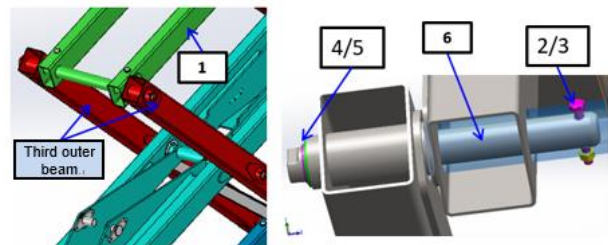

Fig. 4.91 Installation of fourth layer fork

1. Fourth inner arm assembly 2. Bolt 3. Nut 4.

Retaining ring 5. Washer 6. Shaft

- a) Push the fork material trolley to the position of the fork-mounted trolley, raise the hydraulic lifting platform, hoist the fourth-layer inner frame of piece 1 to the upper side of the third-layer inner frame, and pay attention to the direction of placement;
- b) Adjust the three-layer outer beam to be concentric with the front end shaft hole of the four-layer inner frame of part 1, and then smash part 6 in from both sides respectively. Note that the end of the shaft fixing hole faces inward and smash in from both sides of the fork;

Note: the opposite side of the shaft shall be protected by personnel to prevent the workpiece from falling;

- c) Install part 5 into part 6 shaft (circlip end) and

install Part 4 into the groove of part 6 with circlip pliers.

- d) Adjust the part 6 to make the pin through hole to align the bolt fixing hole of the pin through the four-layer inner frame pipe of the part 1, and insert the part 2 into the four-layer inner frame pipe hole and the part 6 hole, and install the part 3. Note that the bolt of the part 2 fixed at the shaft end should be penetrated from top to bottom; Tighten the part 2/3;

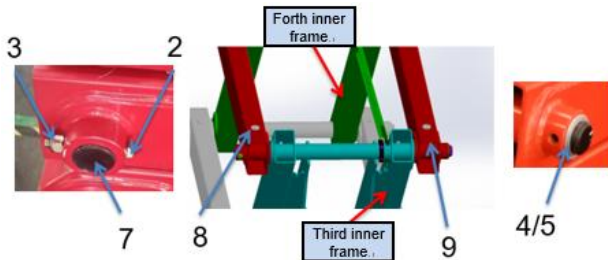

Fig. 4.92 Installation of fourth layer fork

2. Bolt 3. Nut 4. Retainer ring 5. Washer 7. Pin  
8. Left welding of the fourth outer arm 9. Right welding of the fourth outer arm

- e) Lift and place the four-layer outer beam of Piece 8 and Piece 9 to both sides of the four-layer inner frame of Piece respectively, and pay attention to the placement direction of the outer beam (with the mounting rubber plug hole facing upward, the outer beam is divided to left and right);
- f) Adjust the four-layer outer beam part 8 and part 9 to be concentric with the rear end shaft hole of the three-layer inner frame, and then smash part 7 in. Note that the end of the circlip spring installed on the shaft is facing inward, and it is smashed in from the left side of the fork frame. When smashing the shaft, the opposite side needs to be protected by personnel to prevent the workpiece from falling;
- g) Thread part 2 into the left hole of part 7, adjust so that the pin through hole of part 2 is concentric with the bolt hole of the outer beam

shaft sleeve, and install part 2 and part 3. Note that the bolt fixed at the shaft end shall be inserted from the front end of the fork; Tighten the part 2/3;

- h) Install part 5 into the right side of the shaft of part 7, then install the part 4 into the groove of part 7 with a circlip pliers.

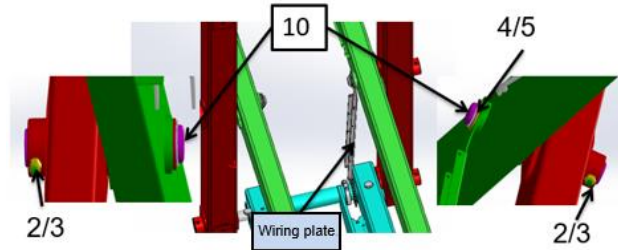

Fig. 4.93 Installation of fourth layer fork

2. Bolt 3. Nut 4. Retainer ring 5. Washer 10. Pin
- i) Adjust the position of the four-layer inner frame and the four-layer outer beam to align the middle shaft hole, smash the shaft of the part 10 on both sides respectively, and pay attention to the shaft mounting circlip end facing inward;
- j) Insert the part 2 into the outer hole of the part 10, adjust the through hole of the part 10 to the clamping hole of the outer beam shaft sleeve, and install the piece 2/3. Note that the bolt fixed at the shaft end should be inserted from the front end of the fork; Tighten the part 2/3;
- k) Install the wiring plate to the inner side of the right shaft, and then install the part 5 into the end side of the k circlip in the shaft of the part 10 (one with wiring plate assembly and two without assembly), and then install the part 4 into the groove of the part 7 with circlip pliers;
- Tools: copper hammer, sleeve, torque wrench, electric impact wrench, circlip pliers
- Tightening torque of part 3:  $40 \pm 4$  N.m
13. Forth-layer pipeline assembly

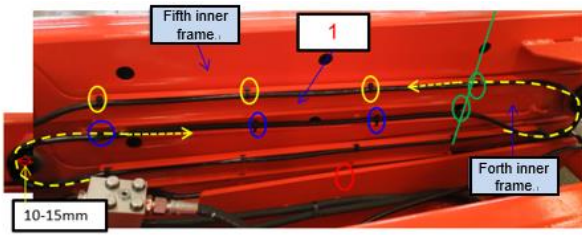

Fig. 4.94 Forth-layer pipeline assembly

## 1. Wiring plate assembly

- a) The PCU harness is bent from the wiring plate to the wiring round steel of forth inner beam according to the above figure (according to the yellow dotted arrow), and then bent from the inner beam wiring round steel to the wiring plate. The key control points are as follows:
- The distance between the top end of the left arc and the top of the arc of the fork pin is 10 mm-15 mm/0.39 in-0.59 in;
  - The harness bending is located inside the fork, as shown in the yellow dotted line;
  - The last end tie point (green circle) of the round steel of the inner beam is on the same vertical line as the wiring plate start tie point (shown in the green straight line in the figure), and the distance between the two green tie points is: 550 mm-590 mm/21.7 in-23.2 in.
  - The wiring plate strapping points are shown in the figure (only the uppermost layer of the wiring plate is used to tie holes).

## 14. Fifth fork assembly

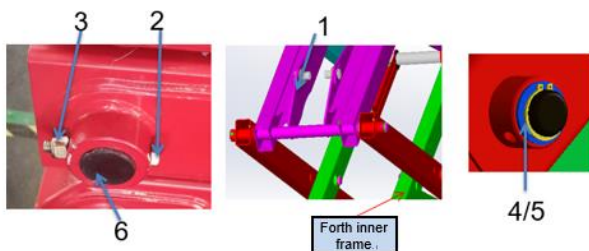

Fig. 4.95 Fifth fork assembly

1. The fifth inner arm assembly 2. Bolt 3. Nut 4. Retainer ring 5. Washer 6. Pin

- a) Push the fork material trolley to the position of the fork assembly trolley, raise the hydraulic lifting platform, put the fifth inner frame of part 1 to the upper side of the four-layer inner frame, and pay attention to the placement direction;
- b) Adjust the forth outer beam to be concentric with the front end shaft hole of the fifth inner frame, and then smash the Part 4 in. Note that the end of the shaft with circlip faces inward and shall be smashed in from the left side of the fork;
- c) Thread part 2 into the left hole of part 6, adjust the pin so that its through hole is concentric with the bolt hole of the outer beam shaft sleeve, and install part 2 and 3. Note that the bolt fixed at the shaft end shall be inserted from the front end of the fork; Tighten parts 2/3;
- d) Install part 5 into the right side of the shaft of part 6, and then install the part 4 into the groove of part 6 with a pair of circlip pliers.

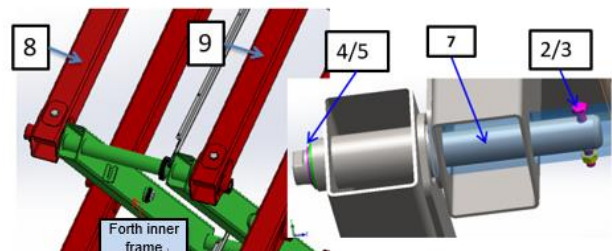

Fig. 4.96 Fifth fork assembly

2. Bolt 3. Nut 4. Retainer ring 5. Washer 7. Pin  
8. Third outer arm left assembly 9. Third outer arm right assembly

- e) Lift and place the outer beams of parts 8, 9 to the fifth inner frame on both sides;
- f) Adjust the fifth outer beam to be concentric with the rear shaft holes of the forth inner frame, and then smash the part 7 from each side of the fork.

Note: the end of the shaft with circlip faces outward and is knocked in from both



sides of the fork. When the shaft is knocked in, personnel shall be provided to protect the opposite side to prevent the workpiece from falling;

- g) Use a monkey wrench to adjust the pin so that its through hole is concentric with the bolt hole of the outer beam shaft sleeve. When mounting parts 2 and 3, note that the bolt fixed at the shaft end shall be threaded from the upper side to the lower side of the fork; Fasten part 8/9;
- h) Install part 5 into the right side of the shaft of part 7, then install the part 4 into the groove of part 7 with a circlip pliers.

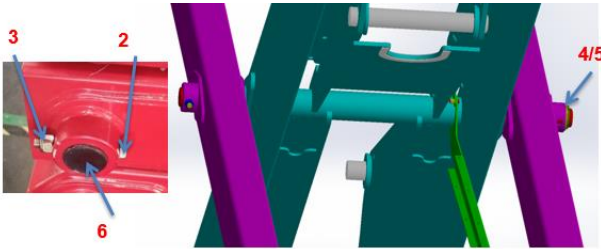

Fig. 4.97 Fifth fork assembly

2. Bolt 3. Nut 4. Retainer ring 5. Washer 6. Pin

- i) Adjust the position of the fifth inner and outer beams to align with the middle shaft holes. Knock in the shaft of part 6 from the left side of the fork, and note that the shaft mounting circlip end is facing inward;
- j) Insert the part 2 into the through-hole of the part 6, adjust the part 6 through-hole to be aligned with the fitting hole of the outer beam shaft sleeve, and install parts 2/3. Note that the bolt fixed at the shaft end should be inserted from the front end of the fork, and tighten the parts 2/3;
- k) Then install the part 5 into the inner side of the shaft of the part 6; Then install the part 4 into the groove of part 6 with a circlip pliers;

Tools: copper hammer, sleeve, torque wrench, electric impact wrench, circlip pliers

Tightening torque of part 3:  $40 \pm 4$  N.m

#### 15. Assembly of fifth upper cylinder (upper end)

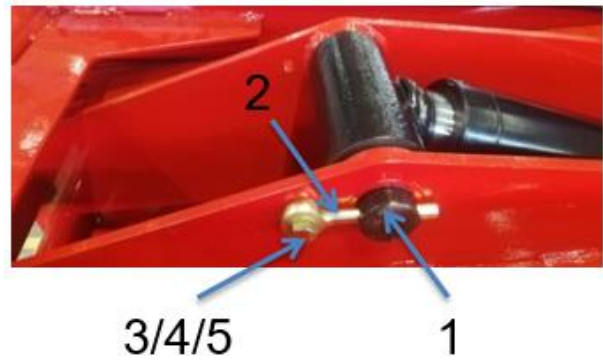

1.Pin 2.Latch 3.Bolt 4.Nut 5.Washer

Fig. 4.98 Assembly of fifth upper cylinder (upper end)

- a) Lift the front end of the upper cylinder, adjust it to the hole of the front lug plate of the fifth inner frame, and then smash the shaft of part 1 into it. Note that the shaft end with hole shall face outward, and the shaft shall be smashed into the fork from the right side;
- b) Insert part 2 into the through hole of part 1, adjust to align the mounting hole of part 2 with mounting hole of the ear plate, fix it with parts 3/4/5, and fasten it reliably;

Tools: copper hammer, sleeve, torque wrench, electric impact wrench

Tightening torque of Part 3:  $52 \pm 5$  N.m

#### 16. Fifth fork (wiring plate) assembly

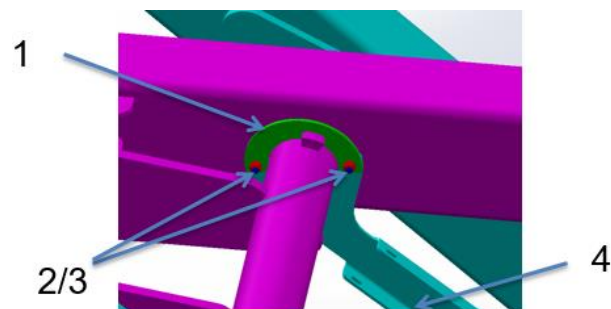

Fig. 4.99 Fifth fork (wiring plate) assembly

1. Arc plate 2. Nut 3. Bolt 4. Wiring plate assembly

- a) Connect and fix the part 4 and part 1 with part 2 and 3 on the central shaft of the fifth fork, as shown in Fig. 4.99, tighten with a ratchet wrench and mark with a Mark pen;

17. Fifth-layer pipeline assembly

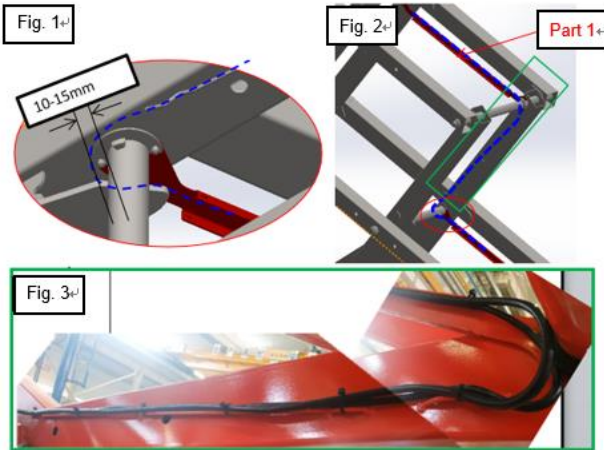

Fig. 4.100 Fifth-layer pipeline assembly

1. Wiring plate assembly

a) Straighten out the PCU harness, route it per the blue dotted line shown in Figure 2, pass it around the middle shaft of the fifth fork, and bind it to the wiring round steel on the inner wall of the fifth fork. The wiring of the power line is exactly the same as that of the PCU. The key control points are as follows:

- The PCU harness arcs along the middle shaft of the fork, and the distance between the top of all pipeline arcs and the arc top of the fork pin is 10-15 mm/0.39-0.59 in (as shown in Fig. 1 of Fig. 1.100);
- Straighten out the PCU harness, bind it to the fifth inner arm wiring round steel, turn it to the inner side of the fork shaft, bind it to the fixing hole at the upper end of the wiring plate of part 2, and the PCU comes into contact with the fork round tube around the arc top point and deviates from the fixing ring by 2 mm/0.08 in;
- When bundling the harness at the wiring plate, only use the upper fixing hole on the wiring board to fix it;
- The position where the PCU harness and power harness are arced should be tied

with small strap.

18. Sixth fork assembly

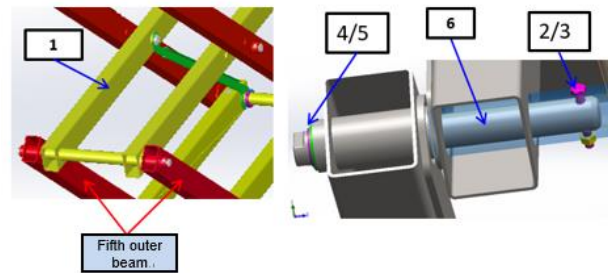

Fig. 4.101 Sixth fork assembly

1. Sixth inner arm assembly 2. Bolt 3. Nut 4. Retainer ring 5. Washer 6. Pin

- a) Lift the sixth inner frame of part 1 onto the fifth inner beam of the fork subassembly trolley;
- b) Adjust the fifth outer frame to be concentric with the shaft hole at the front end of the sixth inner frame, and then knock part 6 in. Pay attention to the inward end of the shaft fixing hole, and knock it in from both sides of the fork;
- c) Adjust the through holes of part 6 to align with the bolt fixing holes of the fork pipe, and install parts 2/3. Note that the bolts fixed at the shaft end must penetrate from the upper end of the fork; Tighten parts 3/4;
- d) Install part 5 into the end of part 6 shaft with circlip, and then install part 4 in the groove of part 6 with circlip pliers.

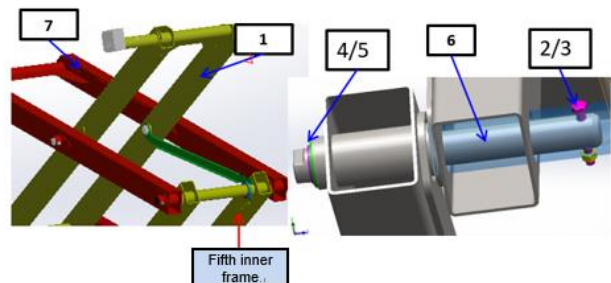

Fig. 4. 102 Sixth Fork Assembly

1. Sixth inner arm assembly 2. Bolt 3. Nut 4. Retainer ring 5. Washer 6. Pin 7. Sixth outer arm assembly

- e) Lift the outer beam of part 7 to the outer side

of the sixth inner arm assembly of part 1, adjust the sixth outer arm of part 7 to have it concentric with the shaft hole of inner frame of the fifth fork, and then smash part 6 into it from both sides of the fork respectively, and note that the end of the shaft mounted with bolt shall face inward;

- f) Use a monkey wrench to adjust the through hole of part 6 to align with the pipe bolt fixing hole, and install parts 2/3. Pay attention to the bolt of shaft fixing from the upper side to the lower side of the fork; Tighten parts 3/4;
- g) Install part 5 into the right side of the shaft of part 6, and then install the part 4 into the groove of part 6 with a pair of circlip pliers.

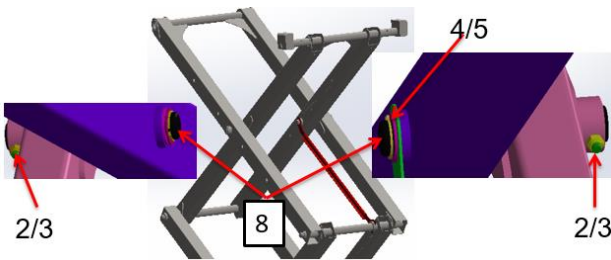

Fig. 4.103 Sixth Fork Assembly

2. Bolt 3. Nut 4. Retainer ring 5. Washer 8. Shaft

- h) Adjust the position of the four-layer inner frame and the four-layer outer beam to align the middle shaft hole, smash the shaft of the part 10 on both sides respectively, and pay attention to the shaft mounting circlip end facing inward;
- i) Insert the part 2 into the outer hole of the part 10, adjust the through hole of the part 10 to the clamping hole of the outer beam shaft sleeve, and install the piece 2/3. Note that the bolt fixed at the shaft end should be inserted from the front end of the fork; Tighten the part 2/3;
- j) Install the wiring plate to the inner side of the right shaft, and then install the part 5 into the end side of the k circlip in the shaft of the part 10 (one with wiring plate assembly and two

without assembly), and then install the part 4 into the groove of the part 7 with circlip pliers;

Tools: copper hammer, sleeve, torque wrench, electric impact wrench, circlip pliers

Tightening torque of part 2: 40±4N.m

19. Sixth-layer pipeline assembly



Use only the upper hole on the wiring plate for fixing

Fig. 4.104 Sixth-layer pipeline assembly

- a) Move the PCU from the inner beam to the outer beam along the middle shaft of the sixth fork;
- b) Lay the front end of the PCU and the power supply harness to the front end of the fork and fix it on the right side of the sixth outer frame. After fixing, place the harness on the sixth fork (avoid landing).

20. Slider assembly

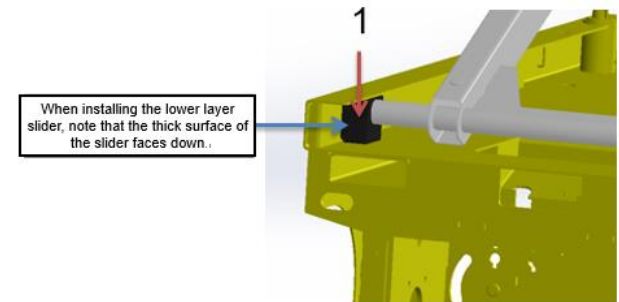

When installing the lower layer slider, note that the thick surface of the slider faces down.

Fig. 4.105 Slider assembly

1. Board

- a) Assemble the slider of part 1 to the rear end of the first outer beam, and make sure that the thicker side of the slider faces down when installing the lower slider.

Note: before installing the fork, measure the size between the slides on both sides of the chassis, and then install the part 2 to adjust the size between the two sliders to ensure that the clearance between the slider and both sides of the slide after fork installation

is not more than 1mm/0.04in;

the chassis, and firmly install and tighten the pin fasteners.

## 4.7 Fork slider replacement

1. Remove the platform.
2. Support and secure the entrance ladder to the appropriate lifting equipment.
3. Remove the fasteners from the access ladder, and then remove the access ladder from the machine.



**WARNING:** Risk of crushing

If it is not properly supported and fixed to the lifting device, the entrance ladder will fall.

4. Fix both ends of the scissor arm to steering end of the machine with a sling or other suitable device.
5. Secure the end of the scissor arm to the non-steering end of the machine with a sling or other suitable device.
6. Remove the upper/lower limit protection switch cover plate at the chassis and remove the cover plate.
7. Remove the upper/lower limit switch and remove the limit switch mounting bracket.
8. At the steering end of the machine, remove the pin connecting the fork and the chassis.
9. Connect the sling on the overhead crane to the fork assembly.
10. Slide the fork assembly out of the chassis until two fork sliders are reached.



**CAUTION:** warning hazard

If it is not properly supported, the fork assembly will fall off when sliding on the chassis.

11. Remove two old sliders and install two new sliders.
12. Slide the fork assembly back to the chassis.
13. Install the removed limit switch assembly in place, insert the pin connecting first inner arm and

## Chapter 5 Chassis



## 5.1 Battery Side Assembly

### 5.1.1 Left Lock Assembly

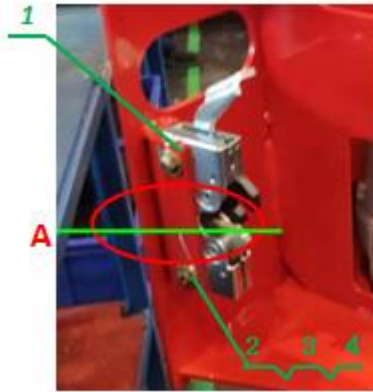
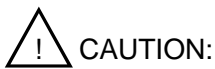

Fig. 5.1 Left Lock

1. Left lock 2. Bolt 3. Washer 4. Washer

1. Take the bolt (Part 2), washer (Part 3), washer (Part 4) and left lock (Part 1) and assemble them to the lock body on the side of the oil tank for welding and tightening;

Note: Please refer to the assembly of left lock for right one.



When the lock body is used in conjunction with the subsequently assembled lock fixing seat, the vertical position of the lock body shall be adjusted so that both latches can be used when it is used in conjunction with the chassis assembly lock fixing seat, and after the battery side door is closed, the side face of the battery is flush with that of the chassis. The installation reference position of the lock body is shown in Fig. 5.1 A.

Part 2 tightening torque: 12 N.m±1 N.m;

Tools: torque wrench QSP25N3, socket wrench 1/2-13 mm/0.51 in

Note: The disassembly of simple components shall be carried out in the reverse order to the assembly, and will not be described in detail. The following cases are the same.

### 5.1.2 Assembly of S1932E II horn and buzzer



Fig. 5.2 S1932E horn and buzzer

1. Horn 2. Washer 3. Bolt 4. Buzzer Mounting Plate 5. Buzzer 6. Buzzer Bracket 7. Buzzer 8. Bolt 9. Washer

1. Take the buzzer (Part 7) and assemble it to the buzzer mounting plate (Part 6), as shown in the figure above, and tighten it; Take the bolt (part 3) and the washer (part 2) to fix the upper combination and the horn (part 1) to the battery side, as shown in Fig. 5.2, and tighten them;

Reference torque of part 3: 28±3 N.m, reference torque of part 8: 5 N.m

Tools: electric impact wrench 51082, socket wrench 1/2-13 mm/0.51 in, socket wrench 8 mm/0.31 in

### 5.1.3 Assembly of S2632 II, S2632E II, S46 II, S46E II horns and buzzers



Fig. 5.3 S2632 II, S2632E II, S46 II, S46E II horns and buzzers

1. Single-tone basin horn 2. Bolt 3. Washer 4.

Nut 5. Buzzer 6. Buzzer bracket 7. Screw 8. Nut  
9. Washer

1. Take the bolt (part 2), washer (part 3) and nut (part 4) to assemble the monophonic disc type horn (part 1) to the battery box and tighten;

2. Install the buzzer (part 5) to the buzzer bracket (part 6), and take two screws (part 7), two nuts (part 8) and two washers (part 9) to install the buzzer bracket (part 6) to the battery box and tighten it.

 CAUTION:

Adjust the horn insert opening at about 90° to the horizontal plane, as shown in Fig. 5.3;

Reference torque of part 2: 28±3 N.m; Reference torque of part 7: 6 N.m;

Tools: Allen wrench 4 mm/0.16 in, electric impact wrench 51082

5.1.4 Assembly of S4650 II and S4650E II horns and buzzers



Fig. 5.4 S4650 II, S4650E II horns

1. Single-tone basin horn 2. Bolt 3. Washer 4. Nut 5. Buzzer 6. Buzzer bracket 7. Screw 8. Nut 9. Washer

1. Take the bolt (part 2), washer (part 3) and nut (part 4) to assemble the monophonic disc type horn (part 1) to the battery box and tighten;

2. Install the buzzer (part 5) to the buzzer bracket (part 6), and take two screws (part 7), two nuts (part 8) and two washers (part 9) to install the buzzer bracket (part 6) to the battery box and tighten it.

5.1.5 Assembly of fuse holder and DC power switch

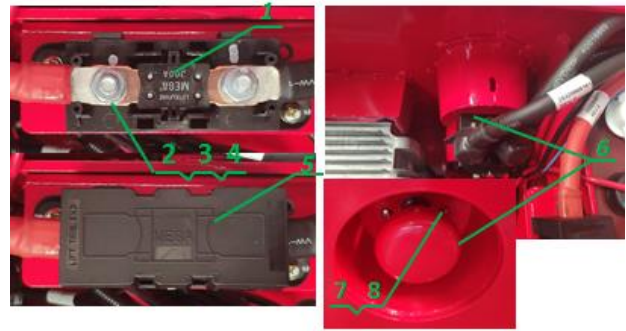

Fig. 5.7 Fuse holder and DC power switch

1. Fuse 2. Screw 3. Washer 4. Nut 5. Fuse holder 6. DC power switch 7. Screw 8. Washer

1. Take the screw (part 2), washer (part 3) and nut (part 4) to assemble the fuse seat (part 5) to the fuse support plate seam on the battery side, and tighten it;

2. Take the Littelfuse (part 1) and pre-install it to the fuse seat using the nut gasket that comes with the fuse seat;

3. Take two screws (part 7) and two washers (Part 8), assemble the DC power switch (Part 6) to the DC power switch seam on the battery side, and tighten it.

The reference torque of part 2 is 3 N.m;

Tools: hexagon head socket wrench 3/8-4 mm/0.16 in, electric impact wrench, open-ended wrench 6-7

5.1.7 S1932 II, S1932E II battery assembly

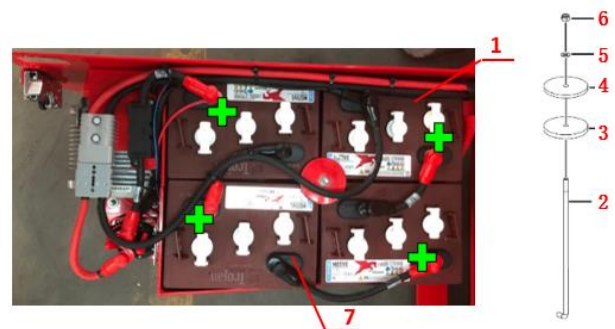

Fig. 5.8 S1932 II, S1932E II batteries

1. Battery 2. Screw 3. Rubber plate 4. Pressure plate 5. Washer 6. Nut 7. Battery sheath

1. Put the 4 batteries into the battery box. The



placement direction is as shown in the figure above and the positive terminal has been marked;

2. Preinstall 8 battery sheaths (Part 7) to the battery terminal;
3. Take the screw (Part 2) and put it into the bottom of the battery box (with the elbow at the bottom) from bottom to top, then place the rubber plate (Part 3), pressure plate (Part 4), washer (Part 5) and nut (Part 6) from bottom to top in sequence shown in the figure above, and tighten them;

Tools: electric impact wrench 51082, socket wrench 1/2-13 mm/ 0.51 in

### 5.1.8 Assembly of S2632 II , S2632E II , S46 II , S46E II , S4650 II and S4650E II batteries

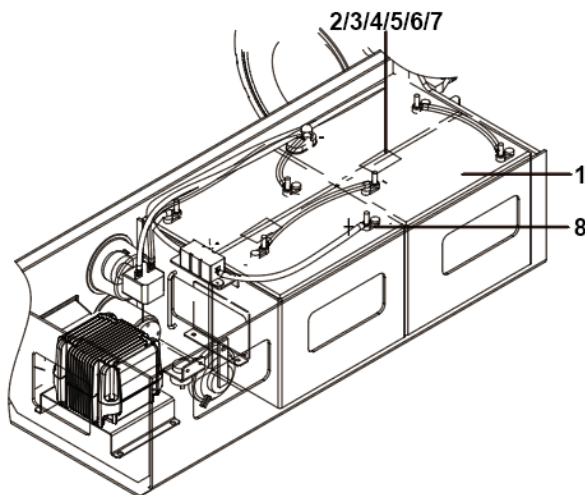

Fig. 5.9 Battery S2632 II , S2632E II , S46 II , S46E II , S4650 II , and S4650E II

1. Battery 2. Screw 3. Rubber plate 4. Rubber plate 5. Pressure plate 6. Washer 7. Nut 8.

#### Battery sheath

1. Put 4 batteries into the battery box with the orientation shown in the figure above;
2. Pre-install 8 battery sheaths (part 8) to the battery terminal;
3. Take the screw (part 2) and insert it into the

bottom of battery box (with the elbow at the bottom) from bottom to top, and place the rubber plate (part 3), rubber plate (part 4), pressure plate (part 5), washer (part 6) and nut (part 7) from bottom to top in sequence, and tighten them;

## 5.2 Fuel tank side assembly

### 5.2.1 Motor and pump assembly

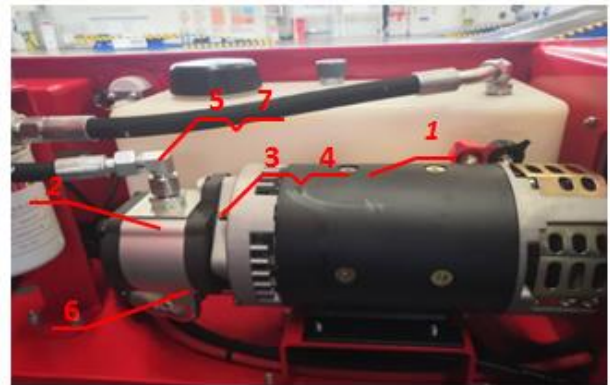

Fig. 5.12 Motor and pump

1. Motor 2. Gear pump 3. Bolt 4. Gasket 5. Fitting 6. Fitting 7. Right-angle fitting

1. Take the bolt (part 3) and gasket (part 4) to assemble the gear pump (part 2) to the motor (part 1); Note: the pump is printed with the arrow on the product marking surface facing upward, and Part 3 is coated with AT262 thread locker;
2. Fit the fitting (part 5) to the pump outlet and tighten it to specified torque (with torque wrench 27); Then connect the right-angle fitting (part 7) to the pump outlet fitting (part 5) without tightening the threads;
3. Install the fitting (part 6) to the pump inlet and tighten it to specified torque.

Tightening torque of part 3:  $20 \pm 2$  N.m; Tightening torque of part 5 and part 6:  $102 \pm 10$  N.m; Part 7 is connected to the pump inlet fitting with a tightening torque of  $42 \pm 4$  N.m

**! CAUTION:**

Before tightening it to specified torque, straighten out the pipeline, tighten the oil pipe and the oil-absorbing tube side, and then tighten it here, as shown in Fig. 5.12;

**! CAUTION:**

- The protective caps of all hydraulic components shall be removed during assembly, and the protective caps cannot be removed in advance;
- Ensure that the rubber hose with a 24-degree cone is concentric with the connected element, manually screw it to the bottom, and then screw it to the specified torque with a torque wrench of the corresponding specification;

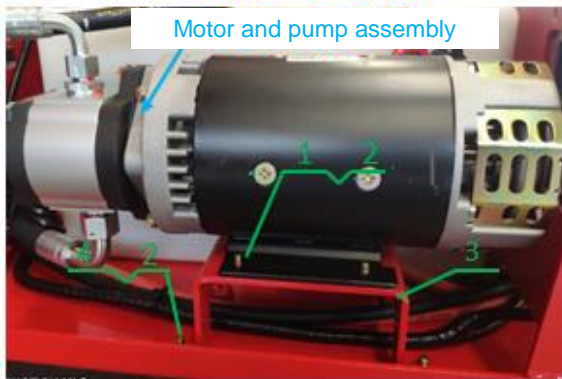

Fig. 5.13 Motor and Pump

1. Bolt 2. Washer 3. Mounting plate weldment 4. Bolt

1. Take four bolts (part 4) and four washers (part 2) to fix the motor mounting plate weldment (part 3) to the bottom of the oil tank side weldment, and tighten them to specified torque;
2. Take four hexagon bolts (part 1) and four washers (part 2) to assemble the motor and pump assembly to the motor mounting plate weldment (part 3), and tighten them to specified torque;

Tightening torque of part 1:  $15\pm 2\text{N.m}$ ; Tightening torque of part 4:  $28\pm 3\text{N.m}$

Tools: electric impact wrench/torque wrench QSP25N3-15N.m

### 5.2.2 Assembly of power unit



Fig. 5.14 Power Unit

1. Install the power unit on the tank side seam and fasten it with bolts and washers.

Note:

- For all hydraulic part protective caps, plugs shall be removed during assembly and shall not be removed in advance;
- Clean the bonding surface with lint-free paper before assembly to ensure that the bonding surface is clean;

### 5.2.3 Assembly of electrical control unit

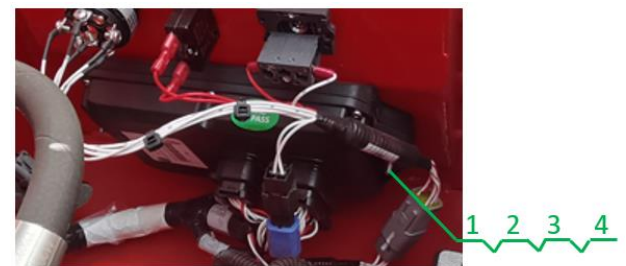

Figure 5.16 Electrical control unit

1. Electrical control unit 2. Screw 3. Washer 4. Nut
2. Take the screw (Part 2), washer (Part 3) and nut (Part 4) to assemble the electric control unit (Part 1) to the corresponding position of seam on the oil tank side; Just tighten it;

### 5.2.4 Filter assembly

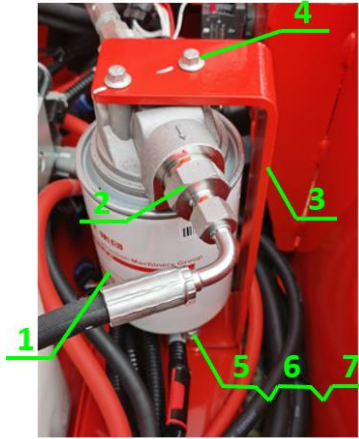

Fig. 5.18 Filter

1. Filter 2. Straight fitting 3. Filter bracket 4. Bolt  
5. Washer 6. Bolt 7. Nut

1. Take the bolt (part 6), nut (part 7) and washer (part 5) and assemble the filter bracket (part 3) to the welded bottom at the oil tank side, and tighten them to specified torque;
2. Take the bolts (part 4) and assemble the filter (part 1) to the filter bracket (part 3), and tighten them to specified torque;
3. Remove the protective cover of the filter. Note: remove the protective cover during assembly, not in advance;
4. Assemble the straight fitting (part 2) to the filter, and tighten it to specified torque; Note: Apply AT569 sealant before assembly of straight fitting;

Part 2 tightening torque:  $85 \pm 10$  N.m; Part 4 tightening torque  $9 \pm 3$  N.m;

Tools: torque wrench SP25N3 and torque wrench SP220 \* 27

### 5.2.5 Platform control panel assembly



Fig. 5.21 Platform control panel

1. Screw 2. Washer

1. Take four screws (Part 1) and four washers (Part 2) respectively to assemble the ground control panel to the ground control panel seam, and then tighten them;

### 5.2.6 Assembly of MCU

Take S4650E II as an example (the MCUs of other models are similar to S4650E II . Please refer to the followings for assembly of MCU):

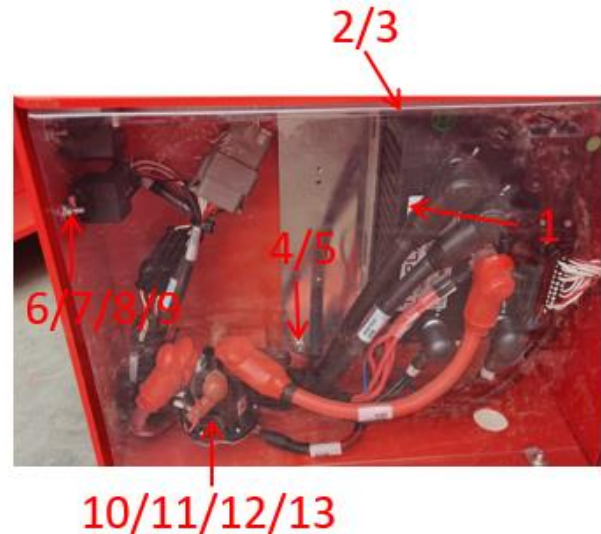

Fig. 5.22 MCU

1. Motor controller 2. Screw 3. Washer 4. Screw  
5. Washer 6. Relay 7. Screw 8. Nut 9. Washer  
10. Main contactor 11. Main contactor bracket 12.  
Screw 13. Washer

1. Take four screws (Part 2) and four washers (Part 3) to assemble the MCU (Part 1) to its mounting plate, and tighten them to the specified torque;

2. Take four screws (Part 4) and four washers (Part 5) to assemble the mounting plate of the MCU to the seam on the tank side, and tighten it to specified torque;
3. Take the screw (Part 7), nut (Part 8) and washer (Part 9) to assemble the relay (Part 6) to the position shown in the figure above, and tighten it to specified torque;
4. Take the screw (Part 12) and the washer (Part 13) to assemble the main contactor mounted above the main contactor bracket to the position shown in the figure above, and tighten them to specified torque.

### 5.3 Chassis Components

#### 5.3.1 Assembly of Work Indicator Lamp

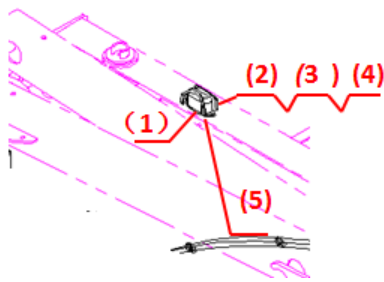

Fig. 5.23 Working Indicator Lamp

1. Working indicator lamp 2. Screw 3. Washer 4. Nut 5. Shield
1. Use the part 2, washer (Part 3), Nut (Part 4) to install two shields (Part 5) and two working indicator lamps (Part 1) to the corresponding installation positions on both sides of the chassis respectively as shown in the figure, and tighten them.

Reference torque of Part 2 is 3 N.m.

Tool: electric screwdriver

#### 5.3.2 Assembly of inclination switch

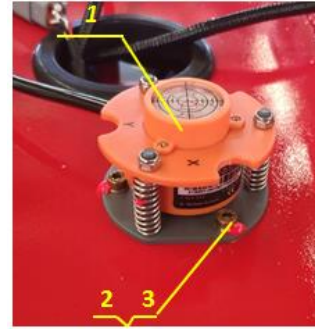

Fig. 5.24 Inclination switch

1. Inclination switch 2. Screw 3. Washer
1. Use the screw (Part 2) and washer (Part 3) to install the inclination switch (Part 1) to the corresponding position shown in the figure and tighten it.

Note: The inclination switch X-X axis of Part 15 is parallel to the lateral center line, and the Y-Y axis is parallel to the longitudinal center line.

The reference torque of Part 2 is 6 N.m.

Tool: Allen wrench 4

#### 5.3.3 Assembly of Upper and Lower Limit Switches



Figure 5.25 Upper, Lower Limit Switch

1. Screw 2. Nut 3. Washer 4. Mounting plate seam 5. Screw 6. Washer
1. Thread the branch wire of the main harness with the upper and lower limit travel switch out of the rubber sleeve above the chassis;
2. Take screws (Part 5) and washers (Part 6), install the mounting plate seam (Part 4) to the chassis assembly, and tighten it;
3. Take the screw (Part 1), nut (Part 2) and

washer (Part 3) and assemble the travel switch on the main harness to the travel switch bracket (Part 5). Mark the upper and lower limits shown in the figure above, apply sealant to the screw, and tighten it to specified torque;

### 5.3.4 Assembly of pit travel switch

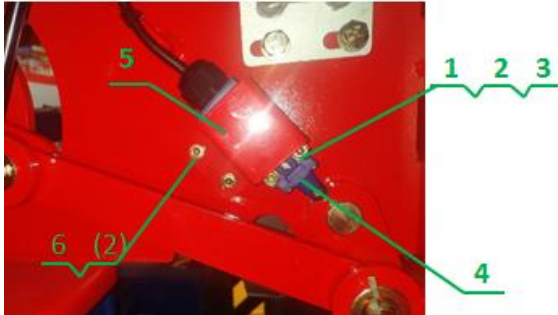

Fig. 5.26 Pit travel switch

1. Screw 2. Washer 3. Nut 4. Travel switch 5. Board 6. Screw

1. Take two screws (Part 1), two washers (Part 2) and two nuts (Part 3) to assemble the stroke switch (Part 4) to the position shown in the figure, and tighten it. The left and right pit switches are assembled as shown in the figure;
2. Take two screws (Part 6) and two washers (Part 2) and assemble the travel switch mounting plate to the position shown in the figure, tighten it; the left and right pit switches are assembled as shown.

### 5.3.5 Assembly of Shaft Fixing Module

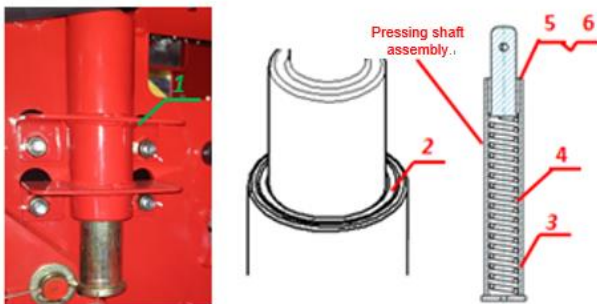

Fig. 5.27 Shaft Fixing Module

1. Shaft fixing module 2. Shaft bush 3. Pipe 4. Spring 5. Shaft bush 6. Shaft bush
1. Subassembly of pressure shaft assembly:

first install the spring (Part 4) into the pipe assembly (Part 3), then install the shaft (Part 6) into the shaft sleeve (Part 5), and finally install the shaft assembly to the pipe assembly (Part 3); Note: when assembling the shaft sleeve (part 6), apply force evenly along the axial direction, and make sure that the rear end face is flush with the pipe assembly after assembling.

2. Assemble the shaft sleeve (part 2) into the shaft holes at both ends of the shaft fixing module (part 1). Note: the assembly shall be carried out with even force along the axial direction.

### ⚠ CAUTION:

Use a top sleeve when pressing the sleeve to prevent the shaft sleeve from going down against the spring; Pay attention to safety when pressing the sleeve. The pipe assembly, shaft sleeve, spring, etc. should be placed perpendicular to the horizontal plane, and the press should be operated at a uniform slow speed.

### 5.3.6 Assembling of gas spring, connecting rod and welded connecting rod assembly

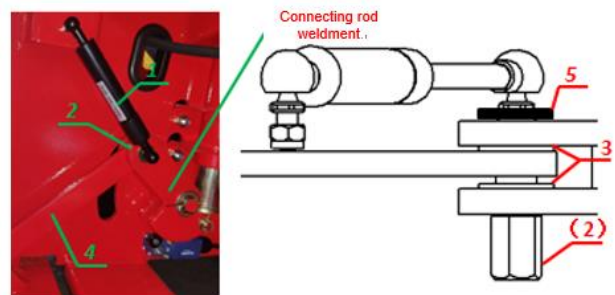

Fig. 5.28 Gas spring, connecting rod and welded connecting rod assembly

1. Gas spring 2. Pin 3. Gasket 4. Connecting rod 5. Washer
1. Pass the gas spring pin (Part 2) through the welded connecting rod assembly, gasket (Part 3), connecting rod (Part 4), gasket (Part 3) and welded connecting rod assembly in

turn, assemble the washer (Part 5) and the ball joint hinge bolt head of the piston rod end of the gas spring (Part 1) to the reserved threaded holes of gas spring pin, and tighten them.

**CAUTION:**

The gas spring shall be on the same side as the cotter pin of the welded connecting rod assembly; Adjusting shim and mount assembly (left).

**5.3.7 Wheel Assembly (S1932 II, S1932E II)**

1. Front wheel assembly

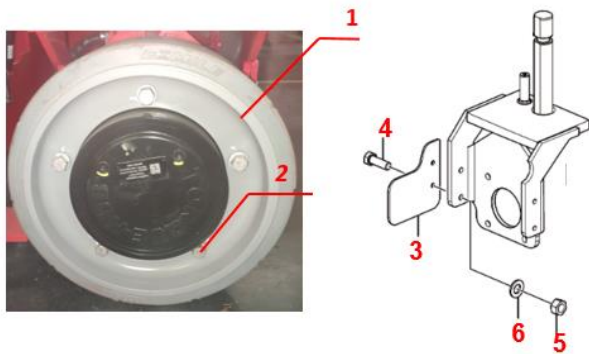

Fig. 5.29 Front Wheel (S1932 II, S1932E II)

- 1. Tire assembly (323 x 100)
- 2. Rim bolt
- 3. Guard plate
- 4. Bolt
- 5. Nut
- 6. Washer

- a. Take the rim nut (Part 2) and fix the tire assembly (Part 1) to the drive motor assembly, and tighten it to specified torque; Part 2 shall be coated with AT262 thread locker before assembly.
- b. Take the bolt (part 4), nut (part 5) and washer (part 6) to assemble the guard plate (part 3) to the left/right steering knuckle.

Part 2 tightening torque:  $120 \pm 10$  N.m; Part 4 tightening torque  $72 \pm 7$  N.m

Tools: pneumatic wrench, open-ended wrench, bolt, nut, washer

2. Rear wheel assembly

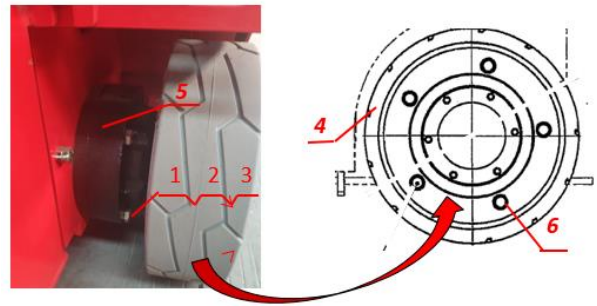

Fig. 5.30 Rear Wheel (S1932 II, S1932E II)

- 1. Bolt
- 2. Washer
- 3. Nut
- 4. Tire assembly (323x100)
- 5. Hub assembly
- 6. Rim bolt

- a. Take the bolts (part 1), washers (part 2) and nuts (part 3) to fix the hubs (part 6) to the corresponding positions on the left and right sides of the chassis, and tighten them to specified torque;
- b. Take the rim bolt (part 6) and assemble the tire assembly (part 4) to the corresponding position of the hub assembly, tighten it to specified torque;

Tightening torque of parts 1 and 6:  $120 \pm 10$  N.m;  
Tools: pneumatic wrench, open-ended wrench, torque wrench, socket, torque spanner

**5.3.8 Wheel assembly (S2632 II, S2632E II, S46 II, S46E II, S4650 II, S4650E II)**

1. Front wheel assembly



Fig. 5.31 Front Wheel Assembly (S2632 II, S2632E II, S46 II, S46E II, S4650 II, S4650E II)

- 1. Rim bolt
- 2. Tire assembly (380 x 130)

- a. Install the tire on the motor on both sides, and then take part 1 (rim bolt) and tighten it to specified torque, as shown in the figure above.

Tightening torque of part 1 rim nut  $120 \pm 10$  N.m;

Tools: torque wrench, open end wrench

2. Rear wheel assembly

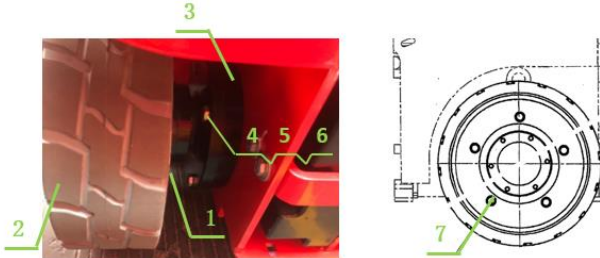

Fig. 5.32 Rear Wheel Assembly (S2632 II, S2632E II, S46 II, S46E II, S4650 II, S4650E II)

1. Rim assembly 2. Tire assembly (380 × 130) 3. Flange plate 4. Nut 5. Bolt 6. Washer 7. Rim bolt

- a. Fix part 1 (hub) and part 3 (flange plate) at the corresponding positions on the left and right sides of the chassis with 8 pieces of following parts respectively, namely part 4 (nut), part 5 (bolt) and part 6 (washer), tighten them to specified torque, as shown in the figure above;
- b. Take Part 2 (tires) and install them on the left and right wheel hubs, and fasten the tires with Part 7 and tighten them to specified torque

Tightening torque for Part 5 and Part 7:  $120 \pm 10$  N.m;

Tools: torque wrench and open-ended wrench.





## Chapter 6 Hydraulics



## 6.1 Hydraulic schematic diagram

### 6.1.1 Hydraulic schematic diagram of S1932II

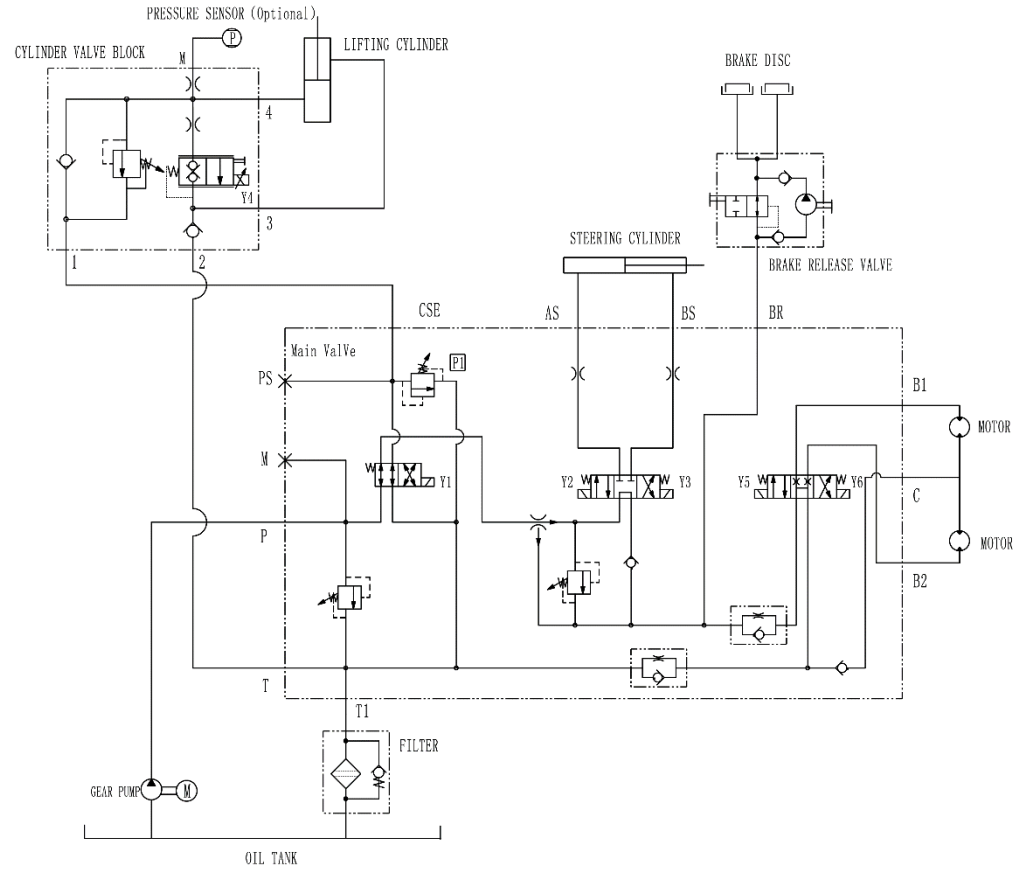

## 6.1.2 Hydraulic schematic diagram of S1932E II

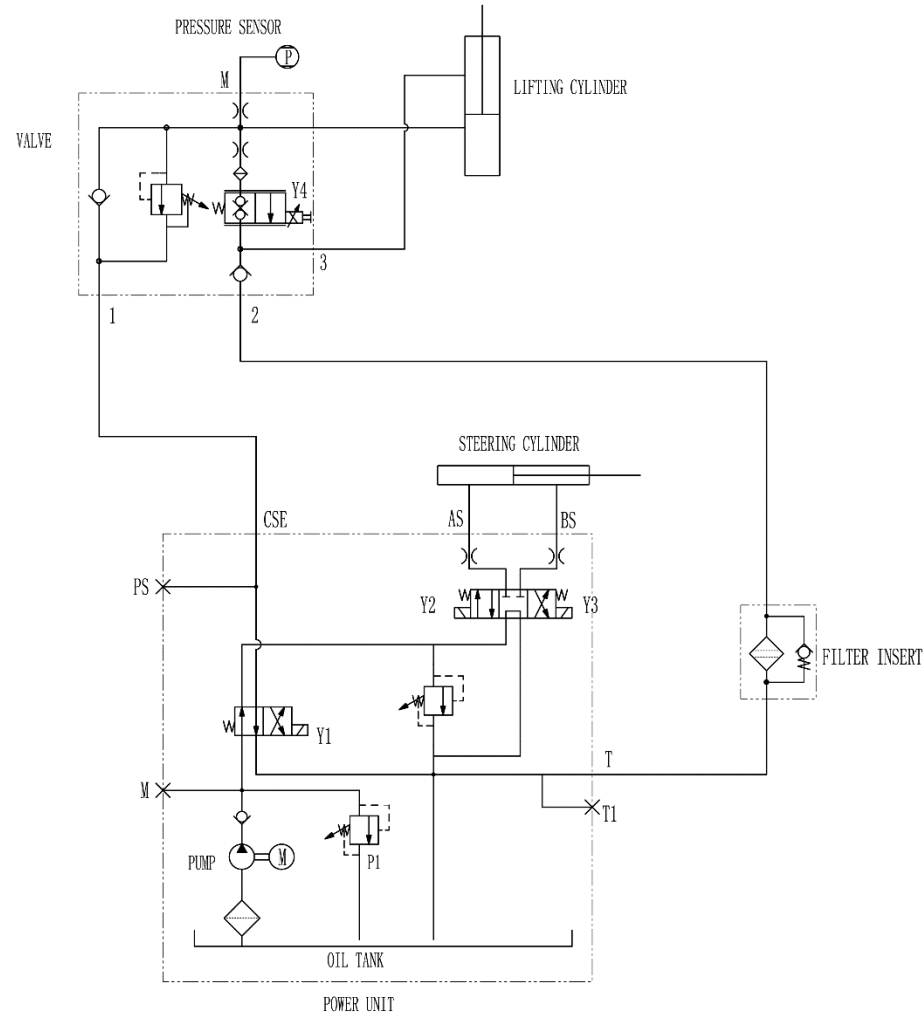

## 6.1.3 Hydraulic schematic diagram of S2632 II

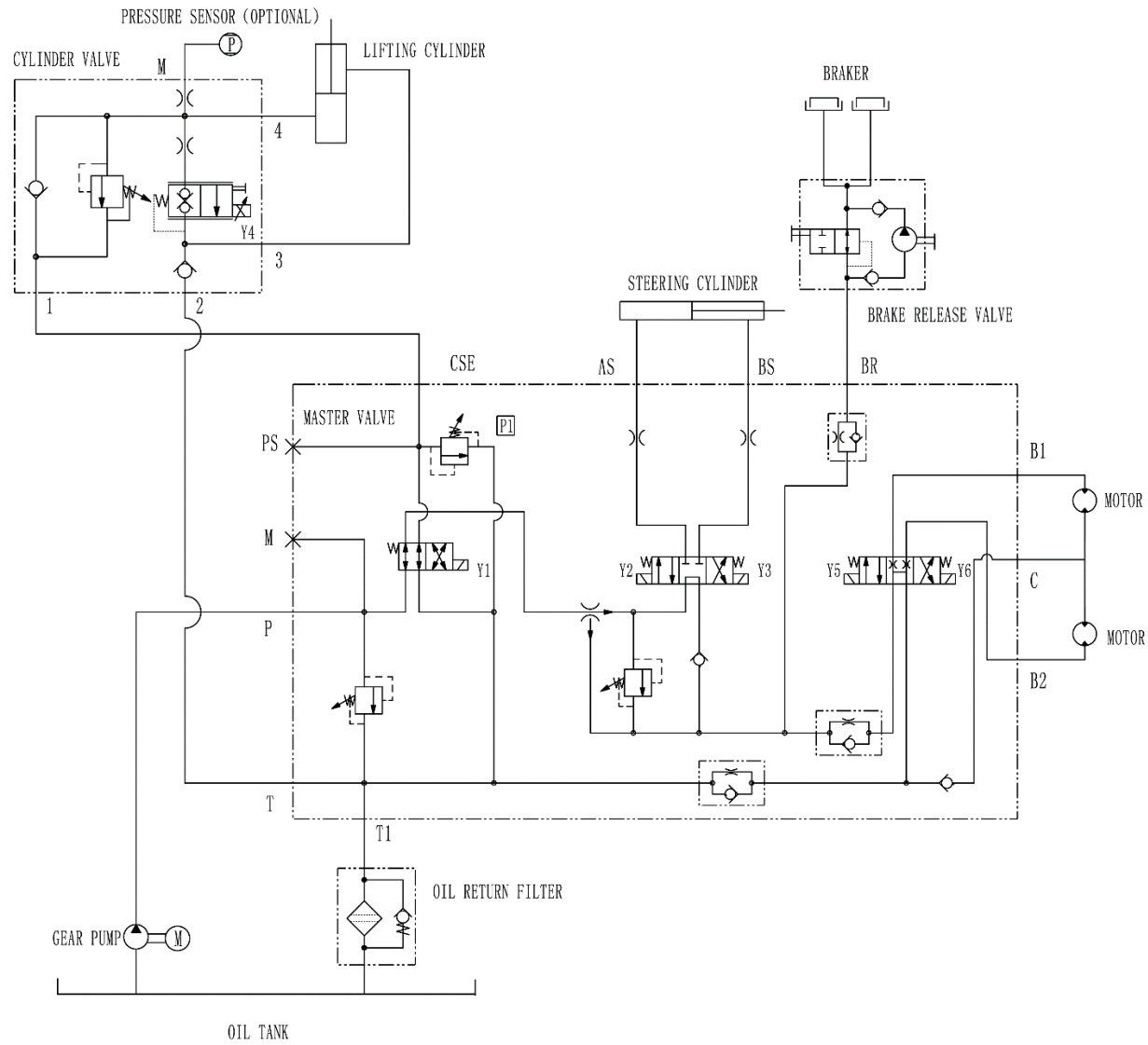

## 6.1.4 Hydraulic schematic diagram of S2632E II

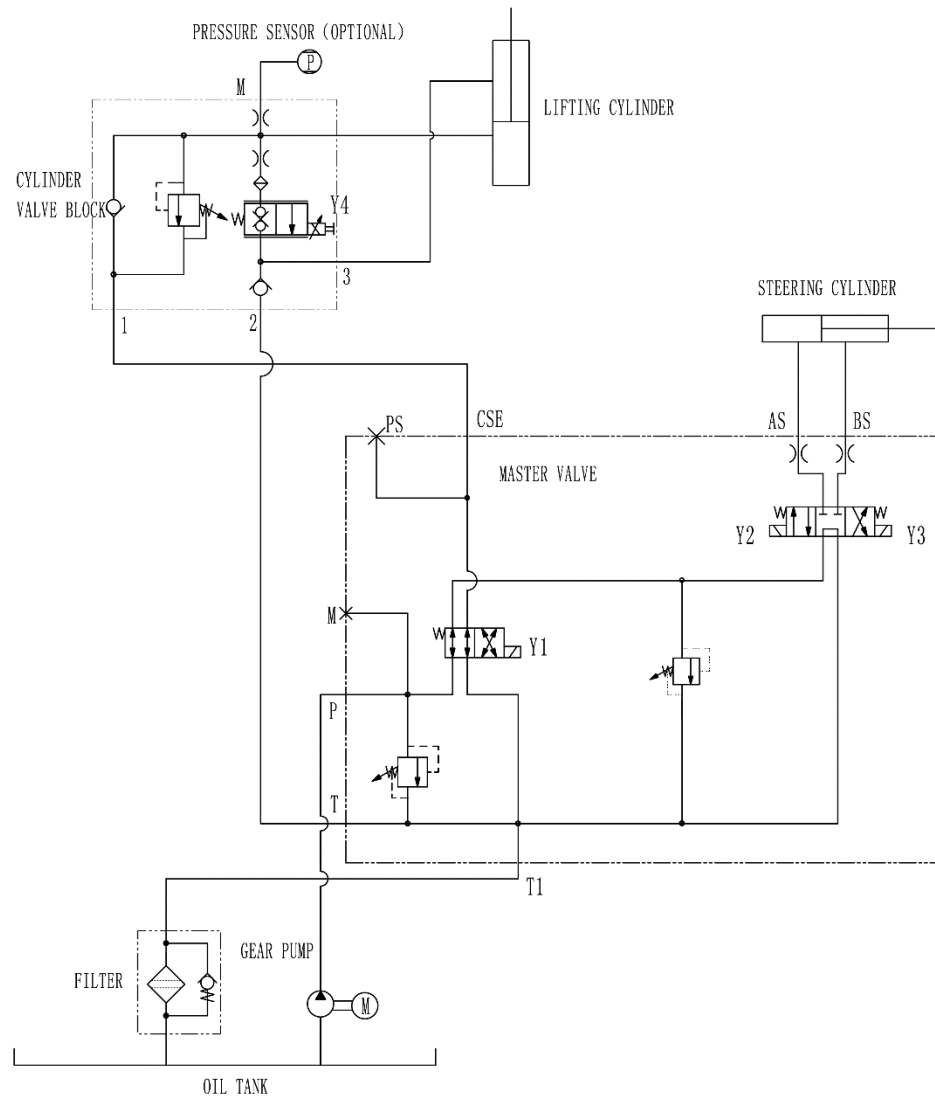

## 6.1.5 Hydraulic schematic diagram of S2646 II

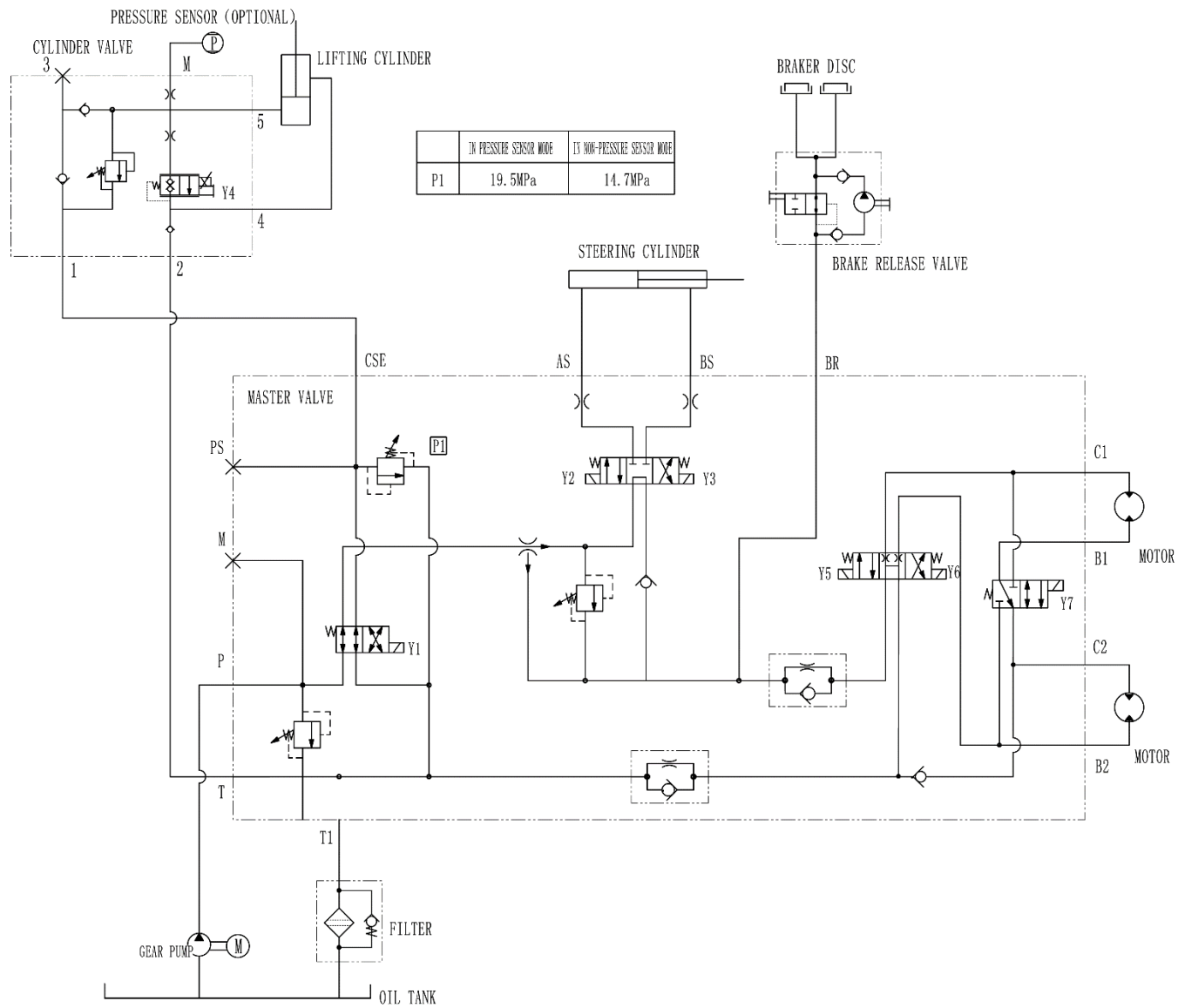

### 6.1.6 Hydraulic schematic diagram of S2646E II

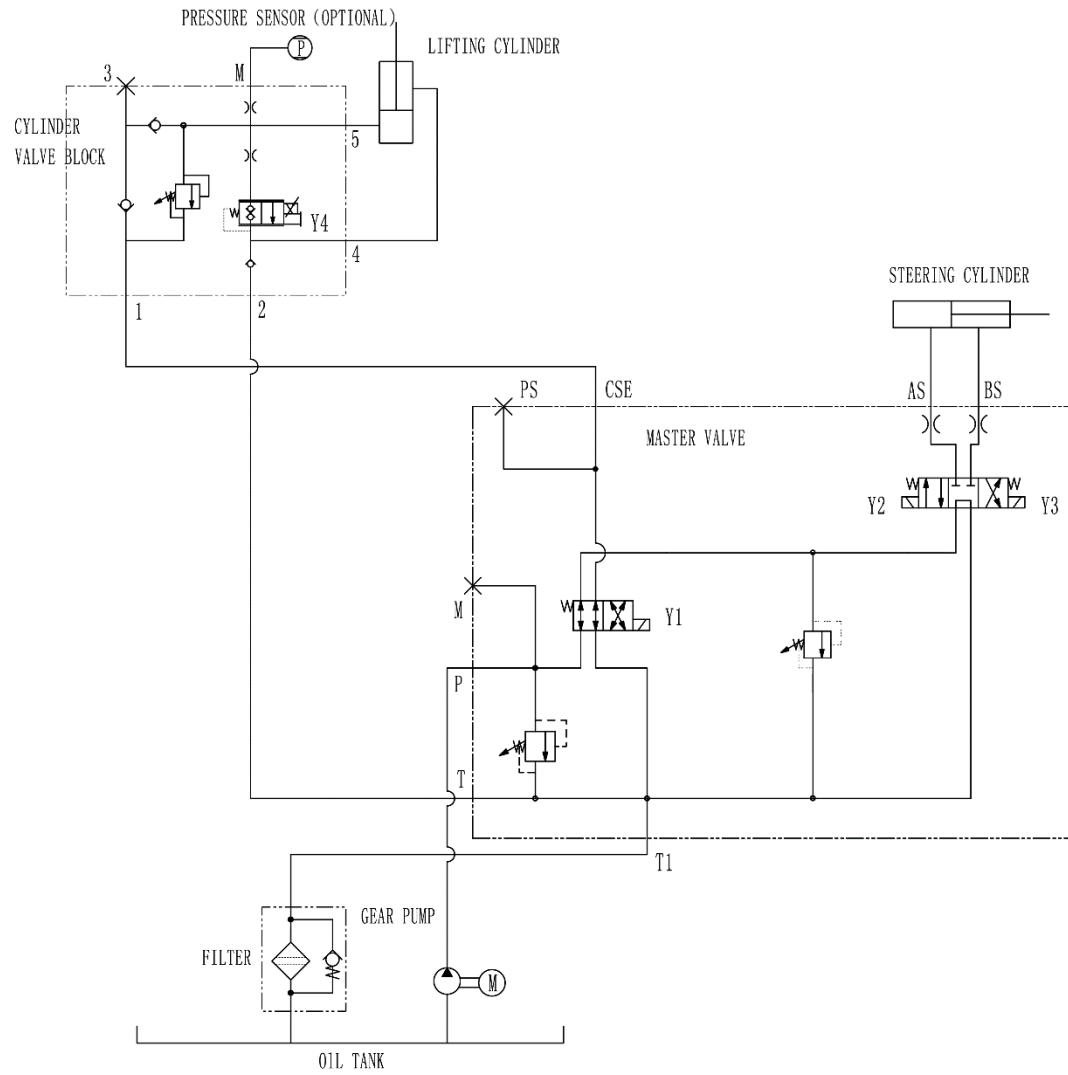



### 6.1.7 Hydraulic schematic diagram of S3246 and S4046 II

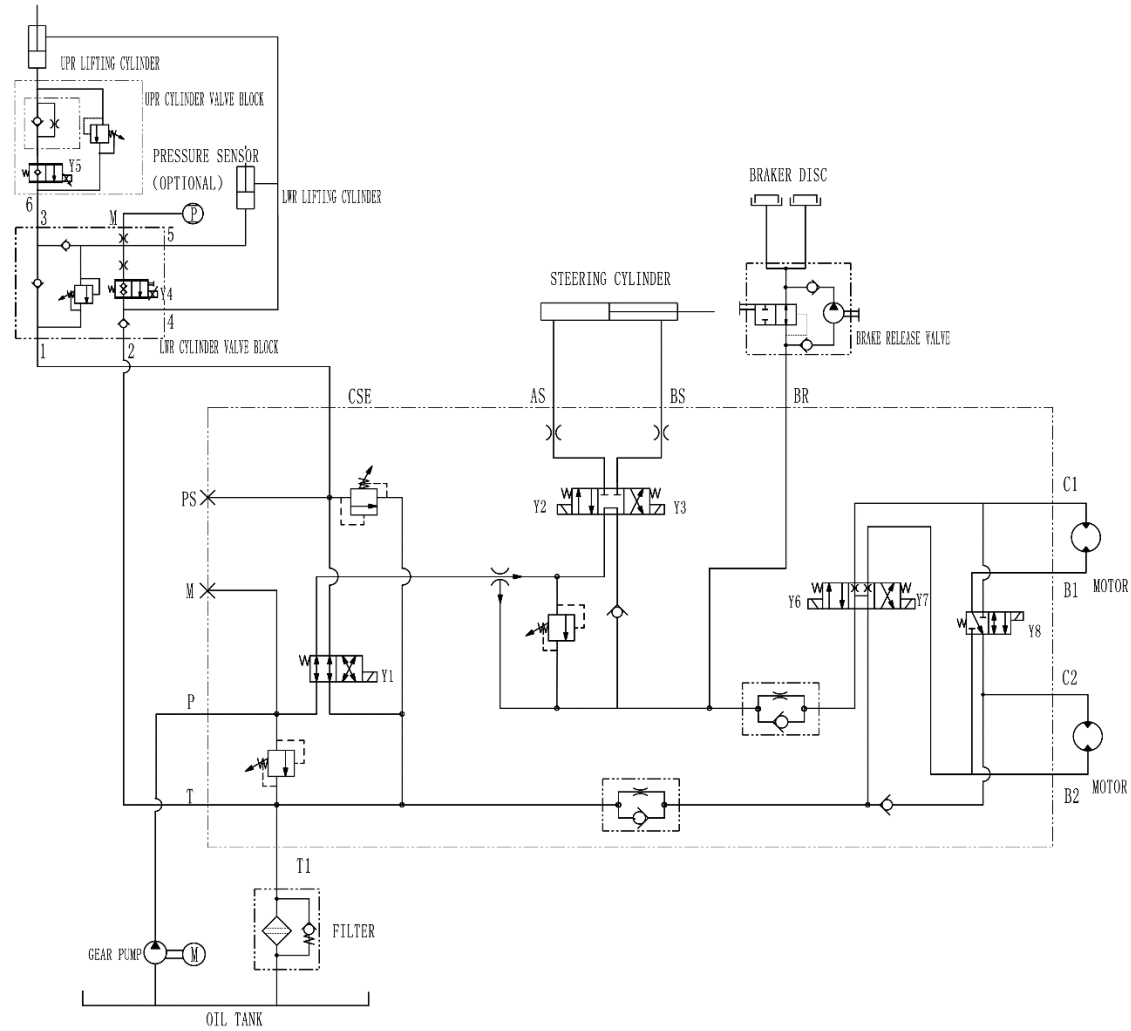

6.1.8 Hydraulic schematic diagram of S3246E II , S4046E II and S4650E II

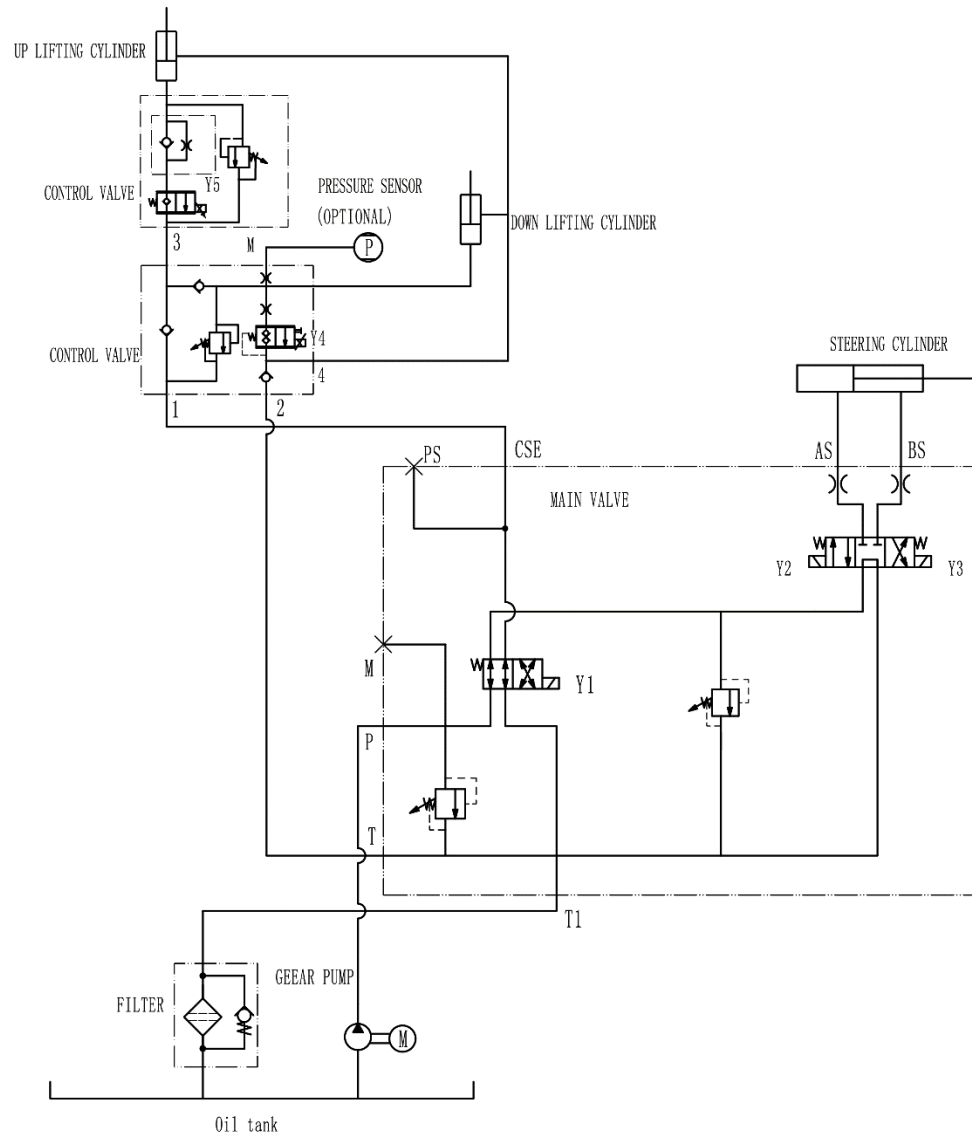

6.1.9 Hydraulic schematic diagram of S4650 II

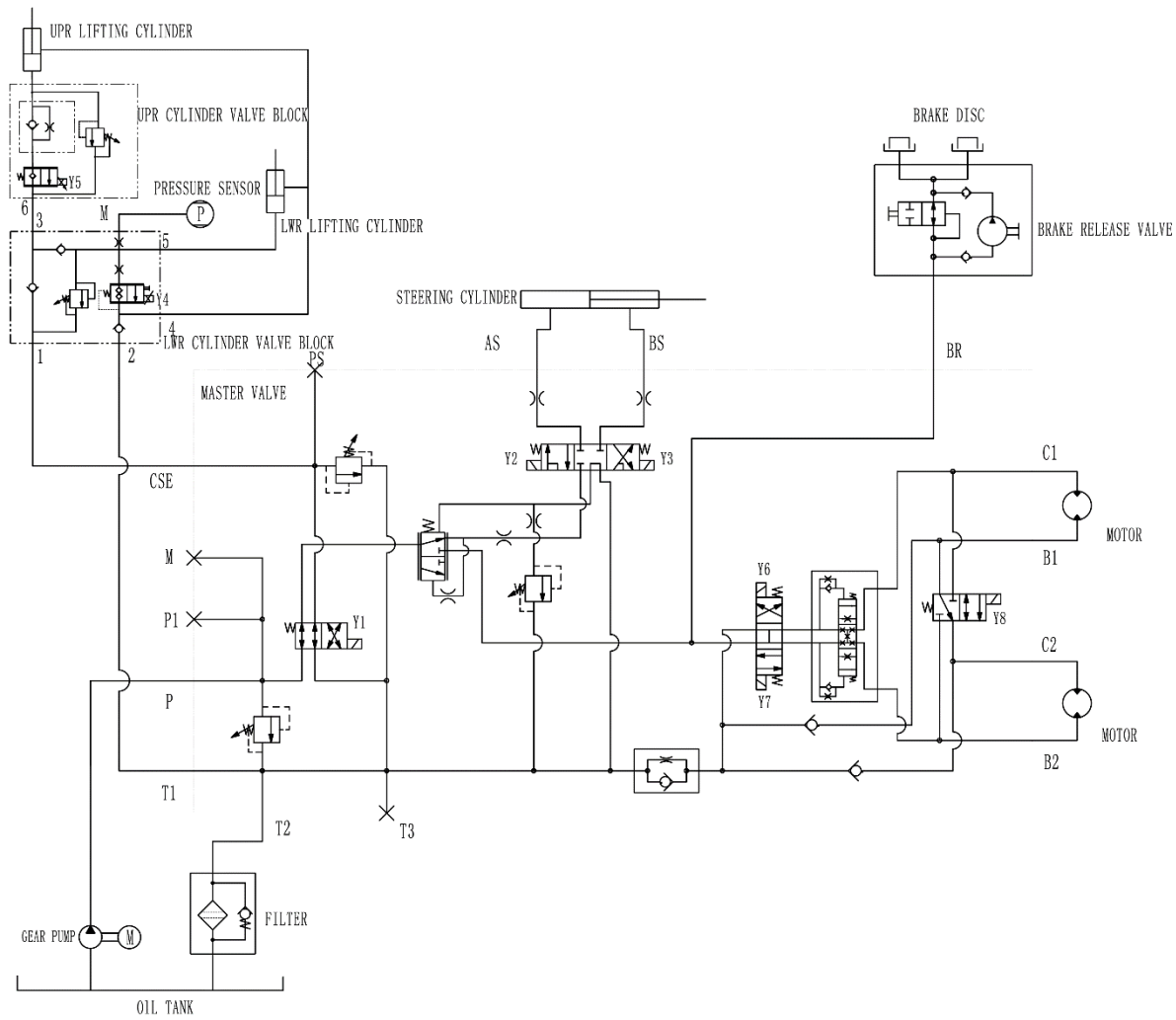

## 6.2 Valve

### 6.2.1 Installing the spool

1. Immerse the spool in clean oil to lubricate the O-ring.
2. Manually screw in the spool until it reaches the top of the O-ring, and then adjust the torque to meet specification requirements.
3. If necessary, install the solenoid coil on the valve stem. Fix the coil to the valve stem with nuts and adjust the torque to meet the specification requirements.

### 6.2.2 Power unit FC-420-1 (S1932E II)

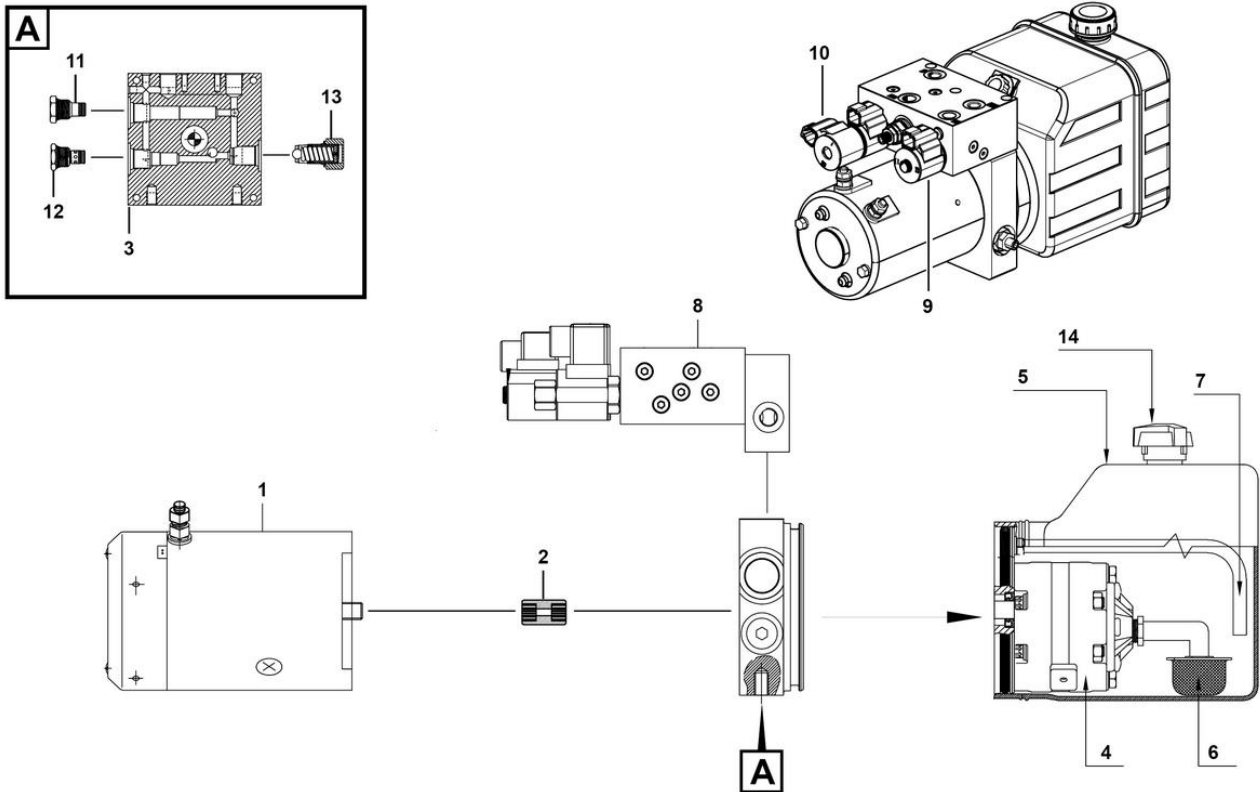

Serial number	Name	Function	Pressure value
1	DC motor (24 VDC, 2.2 KW) 1793-AC	Power source	-
2	Coupling 1118-AA	Connecting shaft	-
3	End cap NF-04-7-AL-2-CN	-	-
4	Gear pump PS3.1	Suction and discharge of hydraulic oil	-
5	Tank 3408-AC	Loading hydraulic oil	-
6	Suction pipe TF-1311	Oil absorption	-
7	Return pipe TF-1300	Return oil	-
8	Oil circuit block HDTMF006	-	-
9	Two-position four-way valve VF-4074	Switch between lifting and lowering functions	-
10	Three-position four-way valve VF-4075	Switch of steering function	-
11	Stop valve 2780-BA	Cut-off, adjust and throttle	-
12	Check valve 2507-AA	One-way flow of hydraulic oil	-
13	Relief valve	Controlling the system pressure	-
14	Oil filler cap 8060-CC	-	-

### Description table of power unit interface

Serial number	Interface name	Function
---------------	----------------	----------

1	AS port	Connecting to steering cylinder large cavity
2	BS port	Connecting to steering cylinder small cavity
3	T-port	Connecting to lift cylinder small cavity
4	CSE port	Connecting to lift cylinder large cavity

### 6.2.3 Scissor lift platform control valve ST5188-AE0A (S1932II, S2632II)

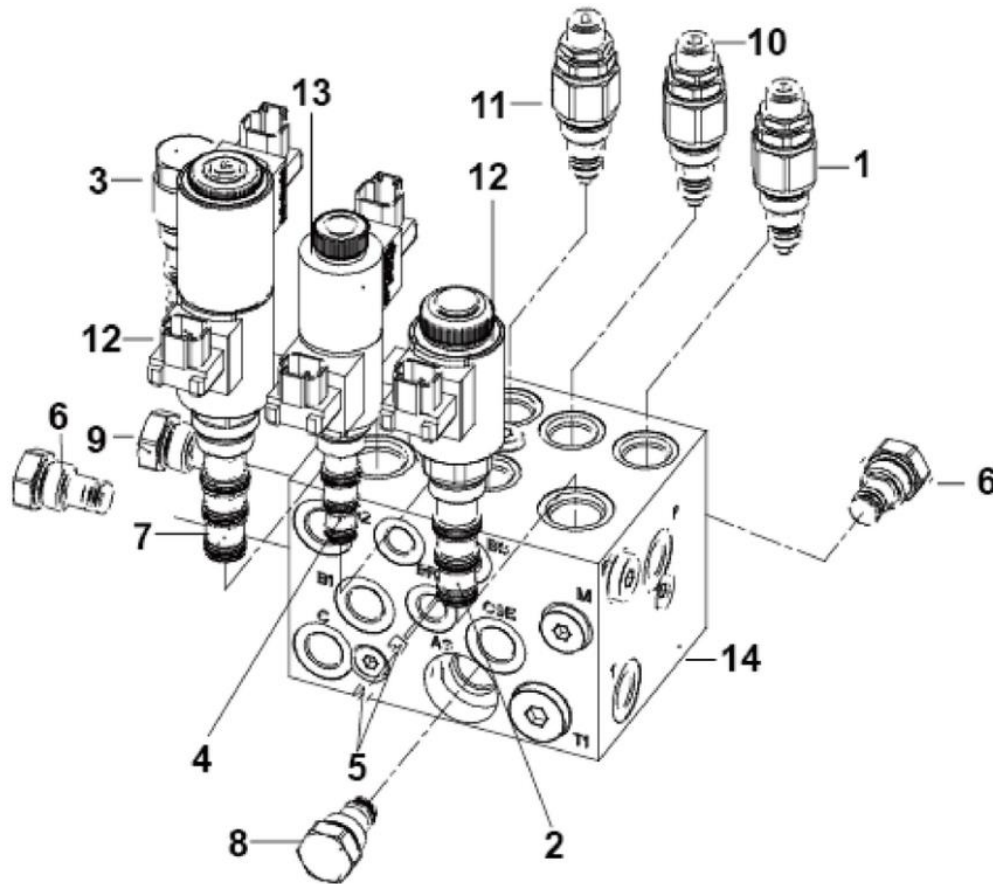

Serial number	Name	Function	Pressure value	Installation torque (Nm)
1	Relief valve STRV08-G-240 A	Maximum pressure of the limit system	-	40-45
2	Two-position four-way solenoid valve E10 N-4 X0	Switching of walking and lifting functions	-	30
3	Priority valve F10 C-32 F-2.5	Prioritized guarantee of steering function	-	33.9
4	Three-position four-way solenoid valve E08 N-4 D	Left/right turn function switching	-	30
5	Damping assembly M6 STTY002-1.0	Ensure the stable flow during steering	-	4
6	Check valve STCV08-0-000 A	One-way flow of hydraulic oil	-	40-45
7	Three-position four-way solenoid valve E10 N-4 F	Forward/backward function switching	-	30
8	Check valve CV08-20-0-N-100	One-way flow of hydraulic oil	-	24.5-27.5
9	Check valve STCV08-0-004 A	One-way flow of hydraulic oil	-	40-45
10	Relief valve assembly STRV08-G-210 A	Limiting maximum lifting pressure	-	40-45
11	Relief valve assembly STRV08-B-120 A	Limiting maximum steering pressure	-	40-45
12	Coil S190-20 DU-26 S	Operation of reversing valve	-	4
13	Coil S130-20DU-20S	Operation of reversing valve	-	4
14	Valve block ST5188-A00 AM	/	-	-

Description form of scissor lifting platform control valve port:

Serial number	Interface name	Function
1	B2 port	Connect to right motor upper oil port
2	B1 port	Connect left motor lower oil port
3	Port C	To left motor upper oil port \ right motor lower oil port
4	Port M	Connect pressure tap
5	Port P	Pump outlet
6	T1 Port	To filter oil inlet
7	BS port	Connecting to steering cylinder small cavity
8	AS port	Connecting to steering cylinder large cavity
9	CSE port	Connecting to lift cylinder large cavity
10	T-port	Connecting to lift cylinder small cavity
11	BR port	Brake release valve oil port
12	PS port	To plug

6.2.4 Scissor lift platform control valve ST6158-AE00 (S2632 E II , S46E II , S4650E II )

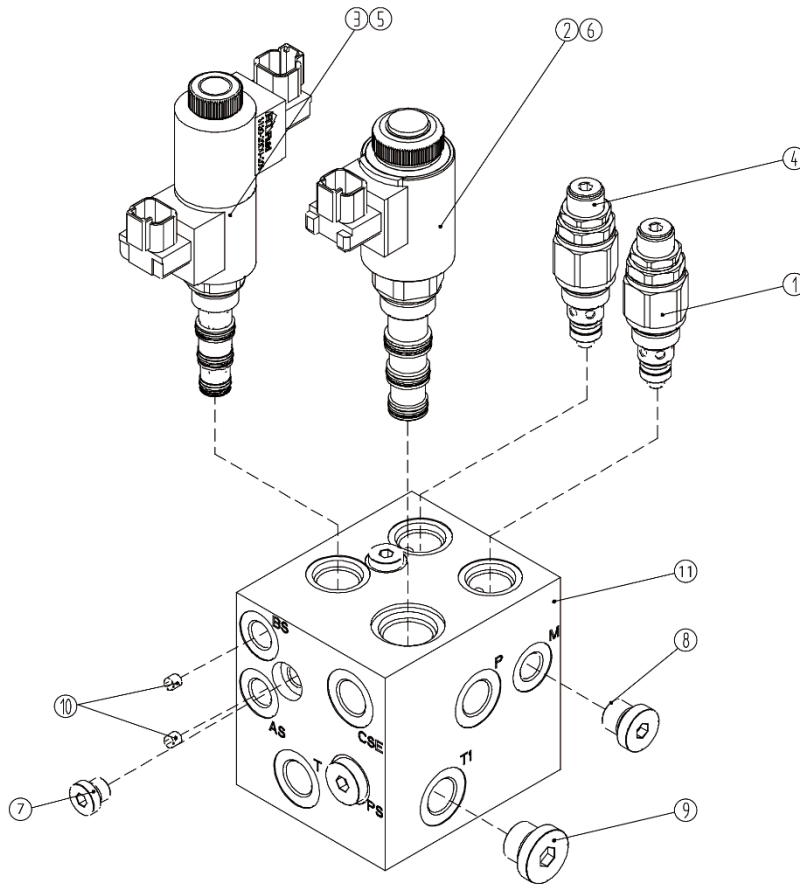

Serial number	Name	Function	Pressure value	Installation torque (Nm)
1	Relief valve assembly STRV08-G-210 A	Maximum pressure of the limit system	-	40-45
2	Two-position four-way solenoid valve E10 N-4 X0	Switching of traveling/lifting functions	-	30
3	Three-position four-way solenoid valve E08 N-4 D	Left/right turn function switching	-	30

4	Relief valve assembly STRV08-B-120 A	Restricting the steering system pressure	-	40-45
5	Coil S130-20DU-20S	Operation of reversing valve	-	4
6	Coil S190-20 DU-26 S	Operation of reversing valve	-	4
7	Plug 4 BN-02 WD	-	-	11-12
8	Plug 4 BN-04 WD	-	-	25-28
9	Plug 4 BN-06 WD	-	-	41-48
10	Damping assembly M6 STTY002-1.0	Controlling the steering speed	-	4
11	Valve block ST5158-A000M	-	-	-

Description form of scissor lifting platform control valve port:

Serial number	Interface name	Function
1	AS port	Connecting to steering cylinder large cavity
2	BS port	Connecting to steering cylinder small cavity
3	CSE port	Connecting to lift cylinder large cavity
4	PS port	To plug
5	Port M	To pressure tap
6	Port P	To gear pump outlet
7	T-port	Connecting to lift cylinder small cavity
8	T1 Port	To filter oil inlet

### 6.2.5 Scissor lift platform control valve ST6887-AE00 (S2646 II, S46 II, S4650 II)

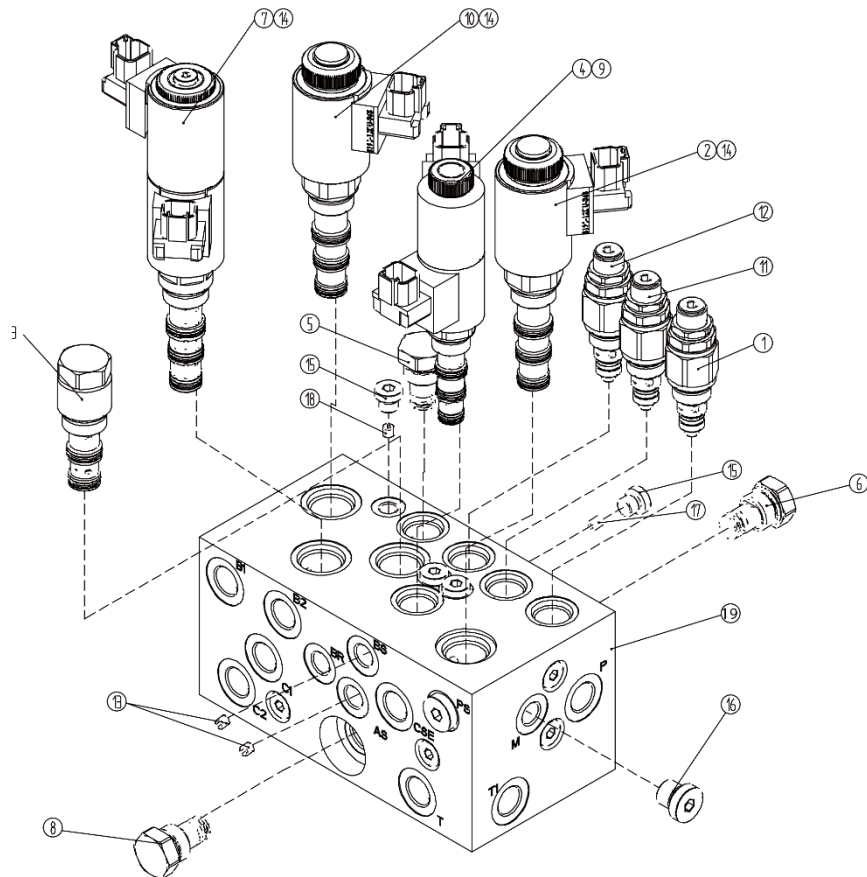

Serial	Name	Function	Pressure value	Installation
--------	------	----------	----------------	--------------

number				torque (Nm)
1	Relief valve STRV08-G-240 A	Maximum pressure of the limit system	-	40-45
2	Two-position four-way solenoid valve E10 N-4 X0	Switching of traveling/lifting functions	-	30
3	Priority valve F10 C-32 F-2.5	Prioritized guarantee of steering function	-	33.9
4	Three-position four-way solenoid valve E08 N-4 D	Left/right turn function switching	-	30
5	Check valve STCV08-0-004 A	One-way flow of hydraulic oil	-	40-45
6	Check valve STCV08-0-000 A	One-way flow of hydraulic oil	-	40-45
7	Three-position four-way solenoid valve E10 N-4 F	Forward/backward function switching	-	30
8	Check valve STCV08-0-007A-01	One-way flow of hydraulic oil	-	40-45
9	Coil S130-20DU-20S	Operation of reversing valve	-	4
10	Solenoid valve E10N-4G0	Stability of the system pressure	-	40
11	Relief valve assembly STRV08-G-210 A	Limit the maximum pressure of the lifting system	-	40-45
12	Relief valve assembly STRV08-B-120 A	Restricting the steering system pressure	-	40-45
13	Damping STTY002-1.2	Ensure stable flow	-	4
14	Coil S190-20 DU-26 S	Operation of reversing valve	-	4
15	Plug 4 BN-02 WD	-	-	17
16	Plug 4 BN-04 WD	-	-	3
17	Built-in check valve STTY002-1.5	One-way flow of hydraulic oil	-	1
18	Damping assembly M6 STTY002-1.0	Ensure the stable flow during steering	-	1
19	Valve block ST4887-A00AM	-	-	-

Description form of scissor lifting platform control valve port:

Serial number	Interface name	Function
1	AS port	Connecting to steering cylinder large cavity
2	BS port	Connecting to steering cylinder small cavity
3	CSE port	Connecting to lift cylinder large cavity
4	PS port	To plug
5	Port M	To pressure tap
6	Port P	To gear pump outlet
7	T-port	Connecting to lift cylinder small cavity
8	T1 Port	To filter oil inlet



6.2.6 Lower cylinder valve block assembly ST5006-AC00 (S1932 II, S1932E II, S2632 II, S2632E II)

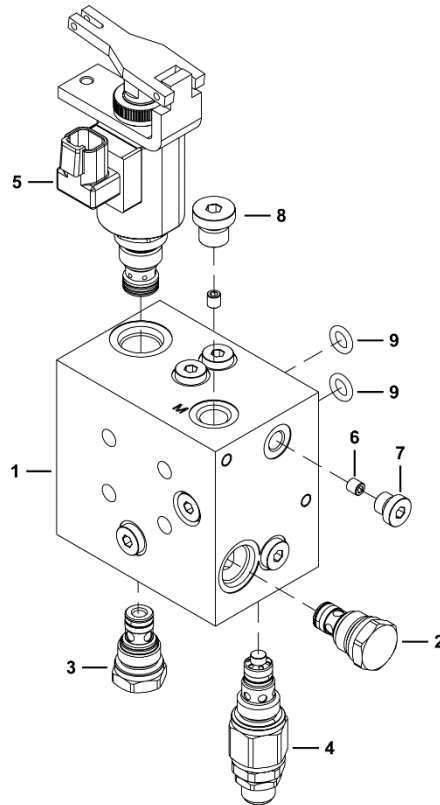

Serial number	Name	Function	Pressure value	Installation torque (Nm)
1	Valve block ST5006-A000M	-	-	-
2	Check valve STCV08-0-000 A	One-way flow of hydraulic oil	-	40-45
3	Check valve STCV08-0-002A	One-way flow of hydraulic oil	-	24.4-27.2
4	Relief valve assembly STRV08-B-120 A	Limiting maximum lifting pressure	-	40-45
5	Proportional solenoid valve PJ16084A0	Proportional control of hydraulic oil flow	-	34-41
6	M6 damping assembly STTY002-0.6	Ensure stable flow	-	2
7	Plug 4 BN-02 WD	-	-	11-12
8	Plug 4MN-14WD	-	-	25-28
9	O-ring 10.77*2.62	Seal	-	-

### 6.2.7 Lower lift cylinder valve block assembly ST4846-AC0A (S46II, S46EII, S4650II, S4650EII)

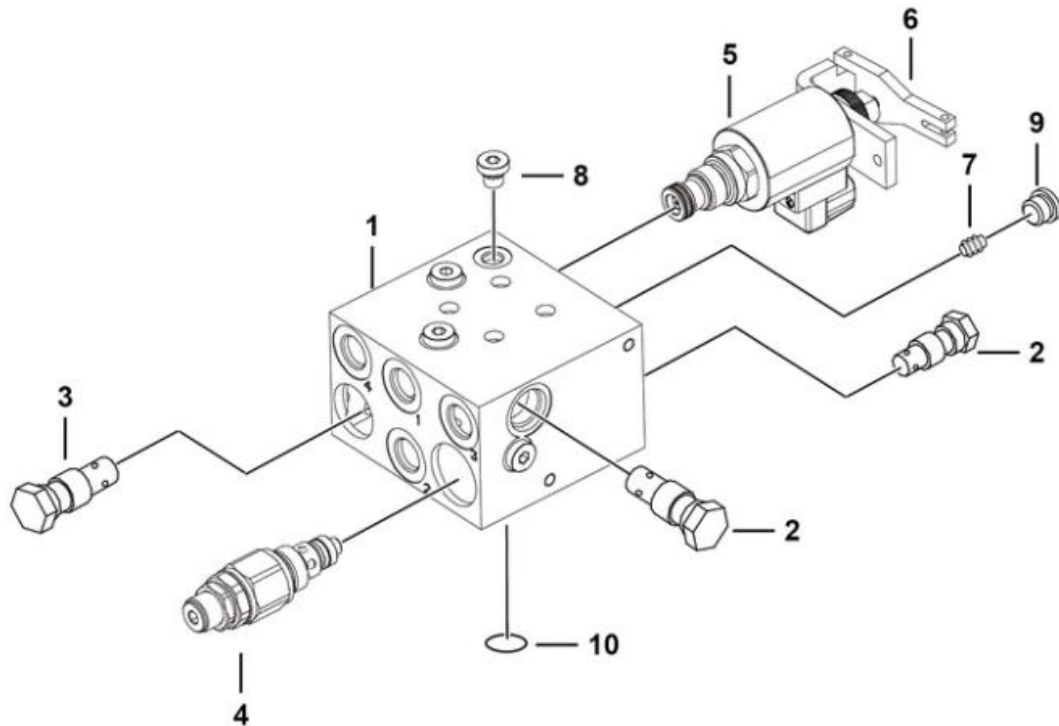

Serial number	Name	Function	Pressure value	Installation torque (Nm)
1	Valve block ST4846-A00AM	-	-	-
2	Check valve STCV08-0-000 A	One-way flow of hydraulic oil	-	40-45
3	Check valve STCV08-0-002A	One-way flow of hydraulic oil	-	24.4-27.2
4	Relief valve assembly STRV08-B-120 A	Limiting maximum lifting pressure	-	40-45
5	Proportional solenoid valve PJ16084A0	Proportional control of hydraulic oil flow	-	34-41
6	Emergency mechanism STTY039	-	-	-
7	M6 damping assembly STTY002-0.6	Ensure stable flow	-	2
8	Plug 4 BN-02 WD	-	-	11-12
9	Plug 4MN-14WD	-	-	25-28
10	O-ring 10.77*2.62	-	-	-

## 6.2.8 Upper cylinder valve block assembly ST4960-AC0B (S4046E II , S4046E II )

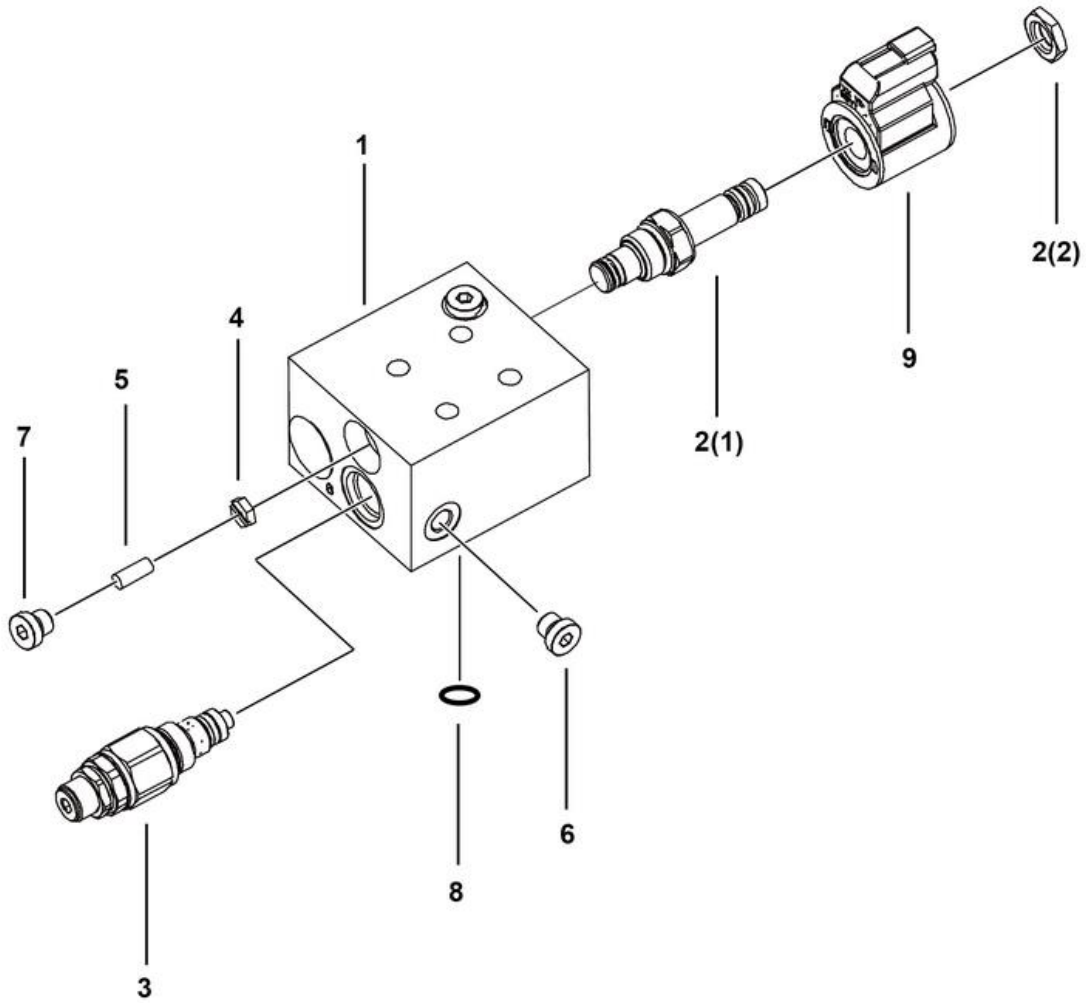

Serial number	Name	Function	Pressure value
1	Valve block 60602920	-	-
2	Proportional valve PFR0.S08.00.N00	Proportional control of hydraulic oil flow	-
3	Relief valve RVC0. S08. 0 B. 000	Limiting maximum lifting pressure	-
4	Coil CCR1 D-24-L0-08	-	-
5	Damping plate ejector rod 30601130	-	-
6	Hexagon socket plug 30600020	-	-
7	Damping plate	Ensure stable flow	-
8	O-ring AS $\Phi 10.77 \times 2.62$	-	-
9	Hexagon socket plug 30600040	-	-

6.2.9 upper cylinder valve block assembly ST4960-AC00 (S4650 II, S4650 E II)

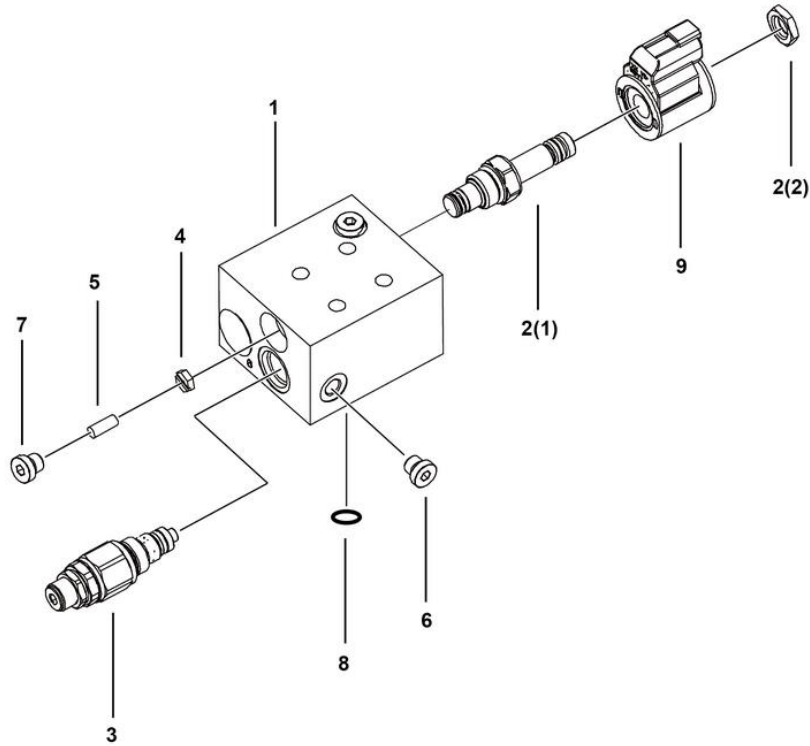

Serial number	Name	Function	Pressure value	Installation torque (Nm)
1	Valve block ST4847-A00 AM	-	-	-
2	Solenoid valve SP08-20-0-N-0	Control of hydraulic oil flow	-	20-25
3	Relief valve STRV08-B-120 A	Limiting maximum lifting pressure	-	40-45
4	Damping plate STTY010-1.5	Ensure stable flow	-	-
5	Damping plate ejector rod STTY038	-	-	-
6	Plug 4 BN-02 WD	-	-	-
7	Plug 4 BN-04 WD	-	-	-
8	O-ring 10.77*2.62	-	-	-
9	Coil assembly 4303624	-	-	-

6.2.10 Testing solenoid valve coil

A normally functioning coil provides electromagnetic force to operate the solenoid valve. The key to normal operation is continuity within the coil. Zero resistance or infinite resistance indicates coil failure. Because the coil resistance is very sensitive to temperature, resistance value that is outside the specification will cause unstable operation. When the coil resistance is lower than the specification, the current increases, and when the coil resistance is higher than the specification, the voltage increases. When the coil resistance is out of specification, the valve may operate, and keeping the coil within the specification will help to ensure that the valve works properly within a certain operating temperature range. Note: if the machine is already running, let the coil cool down for at least 3 hours before testing.

1. Mark and disconnect the wiring on the coil to be tested;
2. Test the coil resistance with a multimeter.

Result: if the resistance is not within  $\pm 10\%$  of the adjusted specification, replace the coil.

## 6.3 Lift cylinder disassembly and assembly

### 6.3.1 Lift cylinder removal



**Danger:** Disassembly of the lift cylinder

requires maintenance personnel having certain maintenance skills, suitable workplace and tools. If the machine is repaired without satisfied maintenance conditions, it may lead to the injury or death of maintenance personnel, and damage of other components and parts of the machine. It is recommended that the damaged lift cylinder be repaired by our service personnel.

#### 1. Removal of upper lift cylinder:

- a. Drive the machine to a safe area (there is a safe operation space around, and the upper part has no interference with the fork lifting).
- b. Operate the ground control panel or use the crane to raise the fork and support the safety support.



**CAUTION:** first confirm that the safety

support is not damaged.

- c. Pull the hand cable to relieve the pressure for 1-2 min, and return the pressure oil in the oil cylinder and oil pipe to the oil tank.

- d. Disconnect the lift oil pipe and cable from the cylinder valve block and cylinder small cavity, and disconnect the cylinder valve and harness. Block the hose fitting on the cylinder.



**CAUTION:** when there is no safety

support, do not stretch the hand or head into the inside of the fork under any circumstances; After the oil pipe is removed, each oil pipe shall be plugged with a plastic wire, and then sealed with a clean plastic bag.

- e. Lift the cylinder rod end with a spreader, remove the cylinder pin at the connection between the upper lift cylinder and the fifth inner frame, and then keep the cylinder horizontal.



**CAUTION:** The bolt and gasket removed

from the pin shall be placed in a fixed position. Before removing the pin, place a wooden board at the lower part of the oil cylinder to prevent the oil cylinder from falling and being damaged; No one shall stand on the opposite side when smashing out the pin to prevent injury. It is recommended that more than two people cooperate.

- f. Remove the cylinder pin at the connection between the upper lift

cylinder and the third inner frame, and slowly lower the cylinder.



**CAUTION:** The bolt and gasket removed

from the pin shall be placed in a fixed position. Before removing the pin, place a wooden board at the lower part of the oil cylinder to prevent the oil cylinder from falling and being damaged; No one shall stand on the opposite side when smashing out the pin to prevent injury. It is recommended that more than two people cooperate.

g. Lift the cylinder out to the fixed position.

## 2. Removal of lower lift cylinder:

a. Drive the machine to a safe area (there is a safe operation space around, and the upper part has no interference with the fork lifting).

b. Operate the ground control panel or use the crane to raise the fork and support the safety support.



**CAUTION:** first confirm that the safety support is not damaged.

c. Pull the hand cable to relieve the pressure for 1-2 min, and return the pressure oil in the oil cylinder and oil pipe to the oil tank.

d. Disconnect the lift oil pipe and cable from

the cylinder valve block and cylinder small cavity; disconnect the harness of cylinder directional control valve and pressure sensor; and block the hose fitting on the cylinder.



**CAUTION:** when there is no safety

support, do not stretch the hand or head into the inside of the fork under any circumstances; After the oil pipe is removed, each oil pipe shall be plugged with a plastic wire, and then sealed with a clean plastic bag.

e. Remove the cylinder pin at the connection between the lift cylinder and the third inner frame, and lift the cylinder rod end with a spreader to keep the cylinder in a horizontal state.



**CAUTION:** The bolt and gasket

removed from the pin shall be placed in a fixed position. Before removing the pin, place a wooden board at the lower part of the oil cylinder to prevent the oil cylinder from falling and being damaged; No one shall stand on the opposite side when smashing out the pin to prevent injury. It is recommended that more than two people cooperate.

h. Remove the cylinder pin at the

connection between the lift cylinder and the first inner frame, and slowly lower the cylinder.

 **CAUTION:** The bolt and gasket

removed from the pin shall be placed in a fixed position. Before removing the pin, place a wooden board at the lower part of the oil cylinder to prevent the oil cylinder from falling and being damaged; No one shall stand on the opposite side when smashing out the pin to prevent injury. It is recommended that more than two people cooperate.

- i. Lift the cylinder out to the fixed position.

### 6.3.2 Assembly of lift cylinder

1. Remove the cylinder package with special tools, avoiding dangerous operations, and place the removed package in a safe area.
2. Install the cylinder valve block on the cylinder and tighten it to specified torque.
3. Install the connector to the valve block oil port and tighten it with a torque wrench.
4. Install the piece pressure sensor to the lower lift cylinder valve block port and fasten it with a torque wrench.
5. Remove the valve block plug, install the throttle valve and tighten the plug here.
6. Install the valve block inlet joint, and tighten it to specified torque.
7. Fit the reversing valve to the cylinder valve block port and fasten it with a torque wrench.
8. Use a spreader to install the partially assembled oil cylinder on the fork, fix both ends with the oil cylinder pin, and tighten the fixing bolt to the specified torque.
9. Connect the hose to the return connector at the cylinder small cavity end and fasten it with a torque wrench.
10. Fit the hose to the cylinder valve block joint and fasten it with a torque wrench.
11. Install the coil and cable bracket to the reversing valve and fasten the coil nut.
12. Install and tighten the cable handle end to the chassis mount, and then connect the other end to the reversing valve cable bracket.

 **CAUTION:** The large end of the

 **CAUTION:** Before assembling the pin,

place a wooden board at the lower part of the oil cylinder to prevent the oil cylinder from falling and being damaged; When assembling the pin, do not stand on the opposite side to prevent injury by a crashing object. It is recommended that more than two people cooperate.

**! CAUTION:** when installing the stay

wire to the reversing valve, adjust the position of the double fixed nut of the stay wire to ensure that there is a 2-3 mm/0.08-0.12 in the gap between the bracket rotating plate of the stay wire and the manual button of the reversing valve, and tighten the double nut at the upper end of the stay wire.

13. Install the pressure sensor connector and solenoid valve connector of the fork harness on the pressure sensor and the coil respectively.

**! CAUTION:** After inserting the

connector, pull it out to ensure that it is connected firmly.

14. Install the valve block guard plate to the cylinder valve block and tighten the bolt.
15. Straighten the oil pipe, harness and cable (they shall not be crossed).
16. Straighten the oil pipe from the rear end to the front end of the fork, fix the oil pipe on the mounting plate at the front end of the fork, and tighten the nut.
17. Lift the fork and support the protective arm in place (place it in the middle of the beam) to ensure that it is hanged firmly and the spreader is not damaged.
18. Insert the inlet and return pipes of the oil

cylinder from the middle hole of the chassis and connect them to the corresponding oil ports of the main valve, adjust the oil pipes to appropriate positions, and fasten them with fixing pipe clamps.

19. Tighten the inlet and return pipe joints at the chassis side door, and then tighten them to specified torque.

## 6.4 Traveling hydraulic assembly

### 6.4.1 Removal of steering cylinder

**! CAUTION:** During removal of the hose

assembly or connector, the connector and the O-ring at the hose end must be replaced (if equipped). All connections must be tightened to the specified torque during installation. Please refer to the Specification for Selection of Tightening Torque of Lifting Platform.

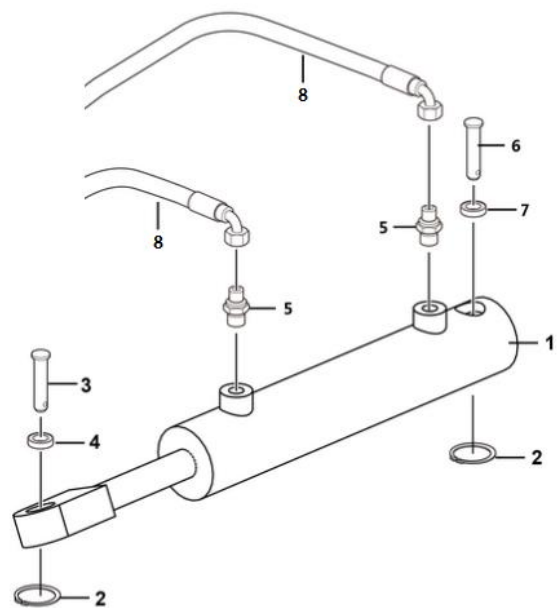



Fig. 6.1 Steering cylinder and pipeline

1. Steering cylinder 2. Retainer ring 3. Steering cylinder pin 4. Shaft sleeve 5. connector 6. Cylinder pin 7. Shaft





sleeve 8. Hose

1. Block the non-steering tire to prevent it from moving.
2. Remove the securing fastener of the pin from the cylinder barrel end pin. Remove the pin.

 **CAUTION:** The quantity and position of the removed washers shall be recorded during removal of fasteners.

3. Mark, disconnect and block the hydraulic hose on the steering cylinder. Cover the connector on the cylinder.
4. Remove the steering cylinder from the machine.

 **Danger:** if there is spray, the hydraulic oil may penetrate into the skin and burn it. Slowly loosen the hydraulic fitting to gradually dissipate the oil pressure. Avoid hydraulic oil injection.

 **CAUTION:** Danger of component damage: if the hose is kinked or squeezed, the hose may be damaged.

#### 6.4.2 Removal of Steering Knuckle

1. Remove steering cylinder.
2. Remove securing fasteners between steering link and steering knuckle.

Note: when removing the securing fasteners, note the number and position of spacer

bushes between the steering knuckle and the steering link.

3. Place the jack in the center under the chassis at the steering end of the machine.
4. Lift the machine approximately 14 inches / 36 cm. Place cushion blocks under the chassis to provide support.
5. Turn the connecting rod to one side so that the steering knuckle can be removed.
6. Remove the tire.
7. Remove the steering knuckle securing fastener and remove the steering knuckle from the machine.

 **CAUTION:** when removing the steering knuckle from the machine, pay attention to the number and position of spacer bush between the steering knuckle and the steering link.

 **CAUTION:** when assembling the nylon gasket, ensure that the chamfered big end of the nylon gasket is downward. At the same time, apply a proper amount of grease to the upper and lower end faces of the nylon gasket before assembly.

#### 6.4.3 Disassembly and assembly of walking motor/drive motor

1. Travel motor removal (hydraulic drive)

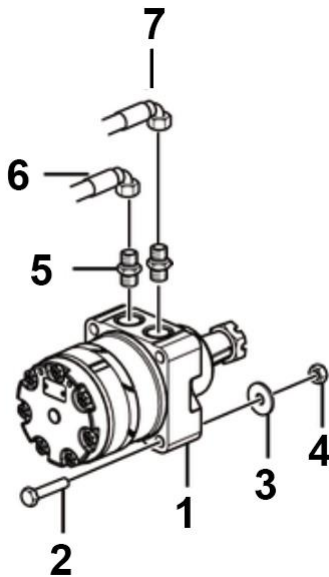

Fig. 6.2 Walking Motor

1. Travel motor 2. Bolt 3. Washer 4. Nut  
5. Connector 6. Hose 7. Hose

- a. Secure the non-steering wheels.
- b. Remove the cotter pin from the wheel castle.

**!** CAUTION: Always replace the cotter pin with a new one after each removal of the castle nut.

- c. Unscrew the wheel castle nut and do not remove it.
- d. Place the jack at the lower center of the drive chassis on the steering gear side of the machine.
- e. Lift the machine about 15 cm/5.9 in from the ground. Place cushion blocks under the chassis for support.

**!** Danger: danger of crushing. Improper chassis installation may cause falling.

- f. Mark and disconnect the hydraulic pipeline of

the travel motor, cover the joint on the drive motor, and protect the pipe fittings of the travel motor properly.

- g. Remove the wheel castle nut, and remove the wheel.

**!** Danger: if there is spray, the hydraulic oil may penetrate into the skin and burn it. Slowly loosen the hydraulic fitting to gradually dissipate the hydraulic oil. Avoid hydraulic oil injection.

**!** CAUTION: Danger of component damage:

if the hose is kinked or squeezed, the hose may be damaged.

- h. Place the steering mechanism in a suitable tooling or device and fix it.
- i. Remove the fasteners from the steering mechanism.

**!** CAUTION: while removing the fasteners, record the number and position of the washers removed.

- j. Remove the travel motor from the steering knuckle.

**!** Danger: personal injury risk.

If the steering mechanism (equipped with a travel motor) is not properly installed, it may fall off when removed from the chassis.

2. Assembly of travel motor (hydraulic drive)

- a) Use bolt 2, nut 4 and washer 3 to pre-tighten the walking motor to the corresponding position of the steering knuckle.
- b) Remove the walking motor hydraulic port protective cover and install connector 5 to the hydraulic motor; The motor connector is 90 ° to the motor end face respectively.



CAUTION: The joint shall be tightened to specified torque after the subsequent pipeline is straightened out.

- c) Fasten the motor fastening bolt and tighten it to specified torque.
- d) Fix the tire assembly on the motor with its attached nut. After tightening the nut to the specified torque, pass the cotter pin through the locking nut slot hole and the brake disc pin hole, and divert the cotter pin.



CAUTION:

- For all hydraulic part protective caps, plugs shall be removed during assembly and shall not be removed in advance;
  - Clean the bonding surface with lint-free paper before assembly to ensure that the bonding surface is clean;
3. Drive motor removal (electric drive)



CAUTION: During removal of the hose assembly or connector, the connector and the O-ring at the hose end must be replaced (if

equipped). All connections must be tightened to the specified torque during installation. Please refer to the Specification for Selection of Tightening Torque of Lifting Platform.

- a. Secure the steering wheel.
- b. Raise the machine about 2 in/5 cm. Place cushion blocks under the chassis to provide support.



Danger: the chassis may fall if it is not properly supported.

- c. Remove the rim bolt. Remove the wheel.
- d. Mark and disconnect the harness of drive motor.
- e. Remove the mounting fasteners of drive motor located at the steering knuckle. Remove the drive motor.

#### 6.4.4 Disassembly and Assembly of Gear Pump

##### 1. Removal of gear pump

- a. Mark and disconnect the cable harness connecting the motor controller to the motor.
- b. Mark, disconnect and block the oil pipe connected to the hydraulic tank from the pump. Cover the connector on the pump.
- c. Mark, disconnect and plug the oil pipe connected to the main valve from the pump. Cover the connector on the pump.

**!** Danger: if there is spray, the hydraulic

oil may penetrate into the skin and burn it. Slowly loosen the hydraulic fitting to gradually dissipate the hydraulic oil. Avoid hydraulic oil injection.

- d. Remove the securing fastener of the motor.
- e. Remove the motor from the machine.
- f. Remove the mounting bolts of the pump and carefully remove the pump.

## 2. Assembly of gear pump

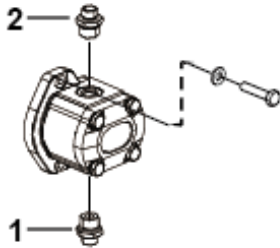

Fig. 6.3 Assembly of Pump

1. Assemble the pump to the motor with bolt and gasket.

**!** CAUTION: place the pump face printed with product label up.

2. Assemble part 2 connector to the pump outlet, and tighten it to specified torque.
3. Assemble the connector of part 1 to the pump oil suction port and tighten it to specified torque

## 6.4.5 6.4.5 Removal and installation of hydraulic tank

### 1. Removal of hydraulic tank (S1932E II)

**!** Danger of component damage

The working area and surface where this step is performed must be clean to ensure that no debris enters the hydraulic system.

**!** CAUTION: During removal of the hose assembly or connector, the connector and the O-ring at the hose end must be replaced (if equipped). All connections must be tightened to the specified torque during installation. Please refer to the Specification for Selection of Tightening Torque of Lifting Platform.

- a. Disconnect the battery pack from the machine.

**!** Danger: Contact with live circuits may cause serious injury or death. Remove all rings, watches and other jewelry.

- b. Mark and disconnect the hydraulic lines from the power unit valve. Cover the connector.
- c. Mark and disconnect the wires to the power unit.
- d. Remove the securing fastener of the tank/pump/valve assembly and remove the power unit assembly from the machine.
- e. Remove the securing fastener of

hydraulic tank, and then remove the hydraulic tank (with gear pump).

- f. Remove the hydraulic tank cover and drain oil into a suitable container.
- g. Remove the securing fastener of hydraulic tank and remove the hydraulic tank from the pump/valve assembly.

## 2. Installation of hydraulic tank (S1932 E II)

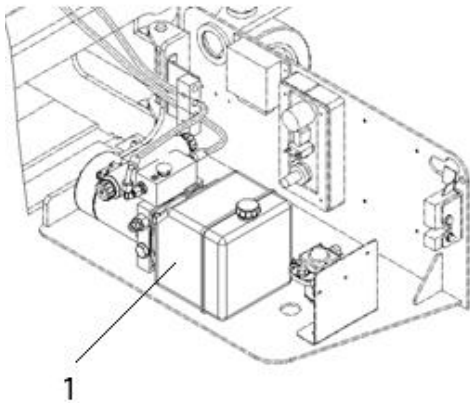

Fig. 6.4 Power Unit

### 1. Power unit

- a. Fix the power unit assembly to the seam on the tank side with fasteners such as bolts.
- b. Connect the hose fitting of the power unit in place by referring to the Line Connection Table.

## 3. Removal of hydraulic tank

(S1932II/S2632II/S2632E II/S46II/S46EII, S4650II/S4650EII)



**Danger:** Contact with live circuits may cause

serious injury or death. Remove all rings, watches and other jewelry.

- a. Disconnect the battery pack from the machine.
- b. Mark and disconnect the return steel pipe of the hydraulic tank from the filter. Remove the return steel pipe from the machine. Cover the connector on the filter.
- c. Mark and disconnect the oil suction steel pipe of the hydraulic tank from the pump. Remove the steel pipe from the machine. Cover the connector on the pump.
- d. Remove the securing fastener of hydraulic tank and remove the hydraulic tank from the machine.



**Danger:** if there is spray, the hydraulic oil may penetrate into the skin and burn it. Slowly loosen the hydraulic fitting to gradually dissipate the hydraulic oil. Avoid hydraulic oil injection.

## 4. Assembly of hydraulic tank (S1932II/S2632II/S2632E II/S46 II/S46EII, S4650II/S4650EII)

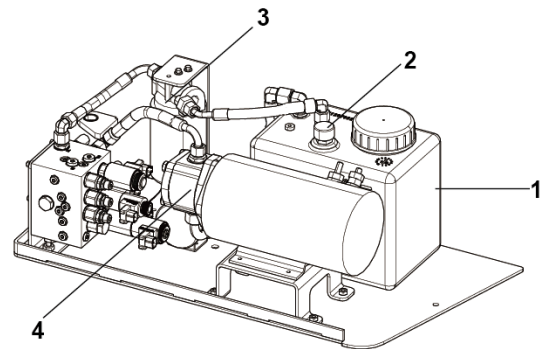

Fig. 6.7 Assembly Layout of Oil Tank

1. Hydraulic tank 2. Air filter 3. Filter 4. Pump
  - a. Fix the oil tank assembly to the seam on the oil tank side with bolts and washers.
  - b. Assemble the air filter to the tank and tighten it.
  - c. Assemble the oil suction steel pipe to the hydraulic tank, and pre-tighten it manually. After straightening out the connecting pipeline, tighten the steel pipe to specified torque.
  - d. Assemble the return steel pipe assembly to the hydraulic tank, pre-tighten it manually, and after straightening the connecting pipeline, tighten the assembly to specified torque.

Note: S1932 II is taken as an example in the above figure, and other models are similar.

**CAUTION:** When tightening the oil suction steel pipe/return steel pipe to specified torque, use a wrench to catch the reserved joint of the oil tank; When tightening the part to specified torque at the pipeline end, use a wrench to catch the oil suction steel pipe/return steel pipe to prevent the oil tank from bearing torque.

## 6.5 Service brake assembly

### 6.5.1 r Removal of brake disc (hydraulic drive)

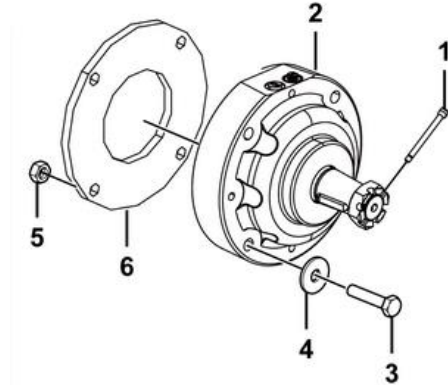

Fig. 6.8 Brake Disc and Tire

1. Pin 2. Brake disc 3. Bolt 4. Washer 5. Nut 6. Flange

**CAUTION:** During removal of the hose assembly or connector, the connector and the O-ring at the hose end must be replaced (if equipped). All connections must be tightened to the specified torque during installation. Please refer to the Specification for Selection of Tightening Torque of Lifting Platform.

1. Support and secure the ladder assembly to the appropriate supporting equipment, remove the ladder mounting fasteners, and remove the ladder assembly from the machine.

**WARNING:** Risk of crushing

If the ladder assembly is not securely installed, it may fall.

2. Secure the steering wheel.
3. Remove the cotter pin from the wheels slotted nut.

 **CAUTION:** Always replace the cotter pin with a new one after each removal of the castle nut.

4. Unscrew the wheels slotted nut, but do not remove it.
5. Place the Jack at the lower center of the non-steering drive chassis.
6. Lift the machine about 5 cm/1.97 in from the ground. Place cushion blocks under the chassis for support.

 **WARNING:** Risk of crushing

Improper chassis installation may cause falling.

7. Remove the wheels slotted nut. Remove the wheel.
8. Mark and disconnect the hydraulic hose on the brake disc, and block the brake disc and oil pipe fitting.

 **WARNING:** danger of personal injury

If the hydraulic oil is sprayed, it may penetrate and burn the skin. Slowly loosen the hydraulic fitting to gradually dissipate the oil pressure. Avoid hydraulic oil injection.

9. Place a support block under the brake disc for support to prevent falling.

10. Remove the brake fasteners and remove the brake disc.

### 6.5.2 Assembly of brake discs (hydraulic drive)

1. Remove the brake disc oil port protective cap.

 **CAUTION:**

- The protective cap shall be removed during assembly and shall not be removed in advance;
  - Clean the binding surface with lint-free paper to ensure that the binding surface is clean.
2. Fit the joint to brake disc oil port, and tighten it to specified torque.
  3. Fix the brake disc at the corresponding positions on the left and right sides of the chassis with the bolt, washer and nut, and tighten it to specified torque.
  4. Connect the brake release valve to the brake disc pipeline, and then tighten it to the specified torque.
  5. Fix the tire assembly to the brake disc with the brake disc's attached nuts. After tightening it to the specified torque, pass the cotter pin through the locking nut slot hole and the brake disc pin hole, and divert the cotter pin.

 **CAUTION:**

1. All hydraulic part protective caps shall be removed during assembly, and shall not be

removed in advance;

2. Make sure that the 24° taper rubber hose is concentric with the connected element, screw it to the bottom manually, and then tighten it to the specified torque with the torque wrench of corresponding specifications.

### 6.5.3 Assembly of Brake Release Valve (hydraulic drive)



**CAUTION:** all protective caps of hydraulic parts shall be removed during assembly, and cannot be removed in advance.

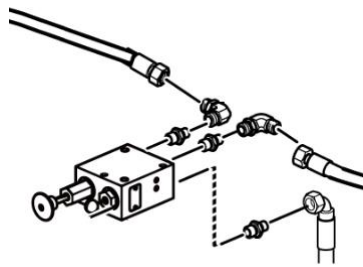

Figure 6.9 Brake Release Valve

1. Remove the oil port protective cap of brake release valve.



**CAUTION:** clean the bonding surface with lint-free paper to ensure that the bonding surface is clean.

2. Assemble the three straight fittings to the three oil ports of brake release valve and tighten them to specified torque, and assemble the right-angle fitting to the two joints A and B.

3. Connect the right brake disc hose to the right-angle fitting at part B, and tighten it to

specified torque.

4. Connect the left brake disc hose to the right-angle fitting at part A, and tighten it to specified torque.

Connect the hose connecting the BR port of the main valve to the connector C, tighten it to specified torque.





## Chapter 7 Electrics



## 7.1 Precautions for work of electrical system

 **WARNING:** no changes to the electrical system are allowed without the permission of our company; Changes will affect the function of the machine and even lead to serious personal injury and machine damage.

 **WARNING:** careless operation of the electrical system will cause serious personal injury and machine damage; Before operation of the electrical system, the instructions described below and related sections must be followed carefully.

 **WARNING:** Other metal items such as watches, rings and bracelets must be removed from the body before work on the electrical system.

## 7.2 Schematic Diagram of Location of Main Electrical Appliances

Except the power unit model, take the S2632II as an example:

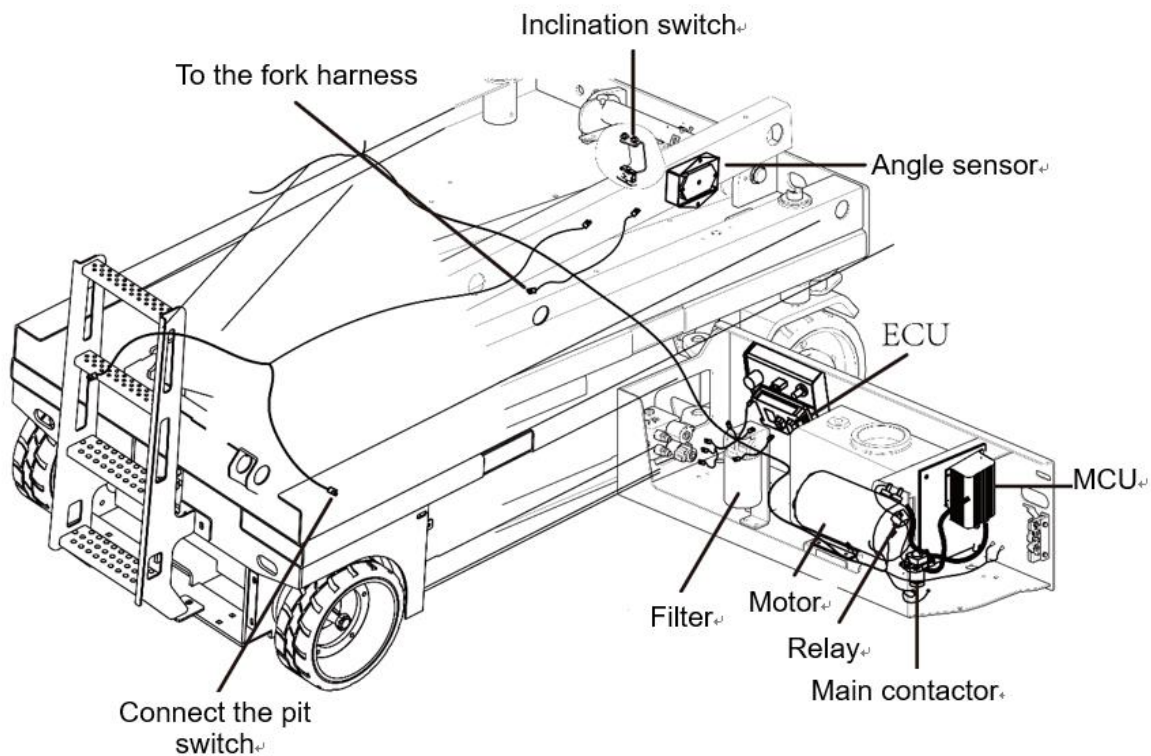

Schematic Diagram of Location of Main Electrical Appliances for S1932E II :

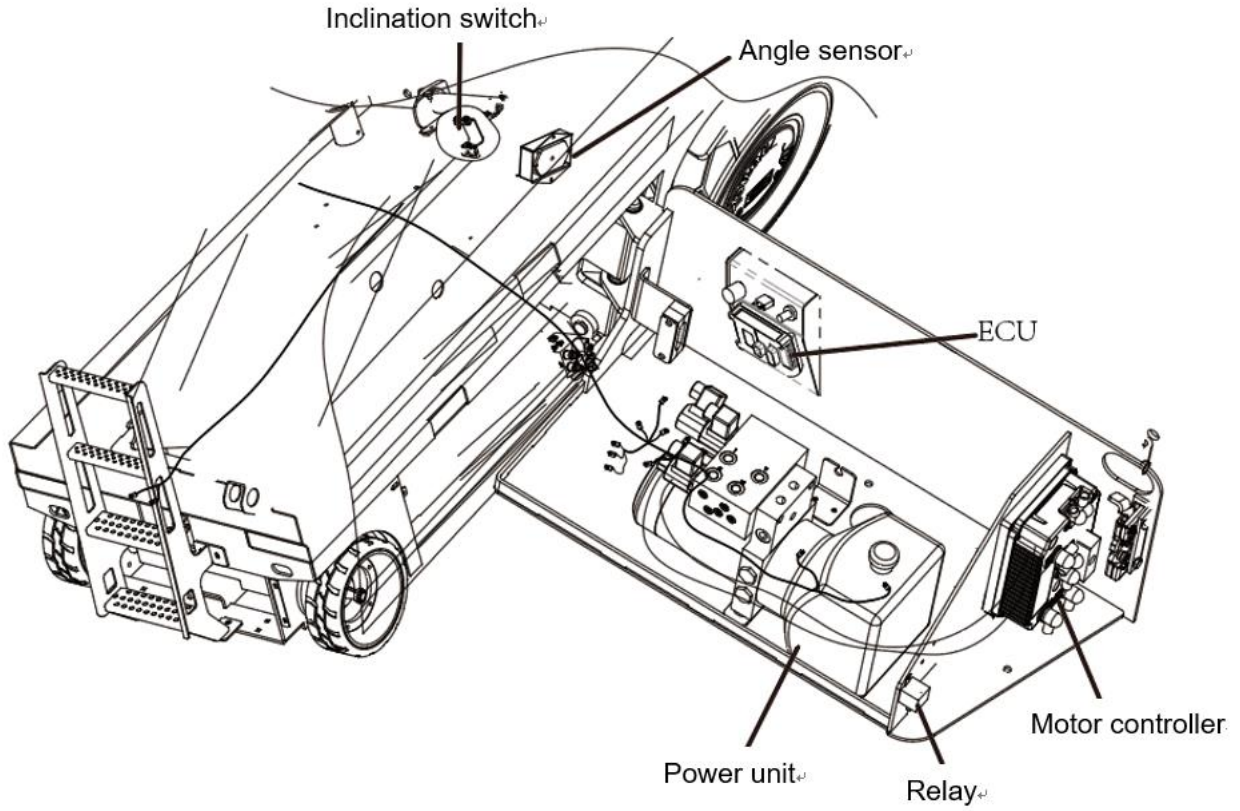

## 7.3 Electrical schematic diagram

### 7.3.1 Electrical schematic diagram (electric drive)

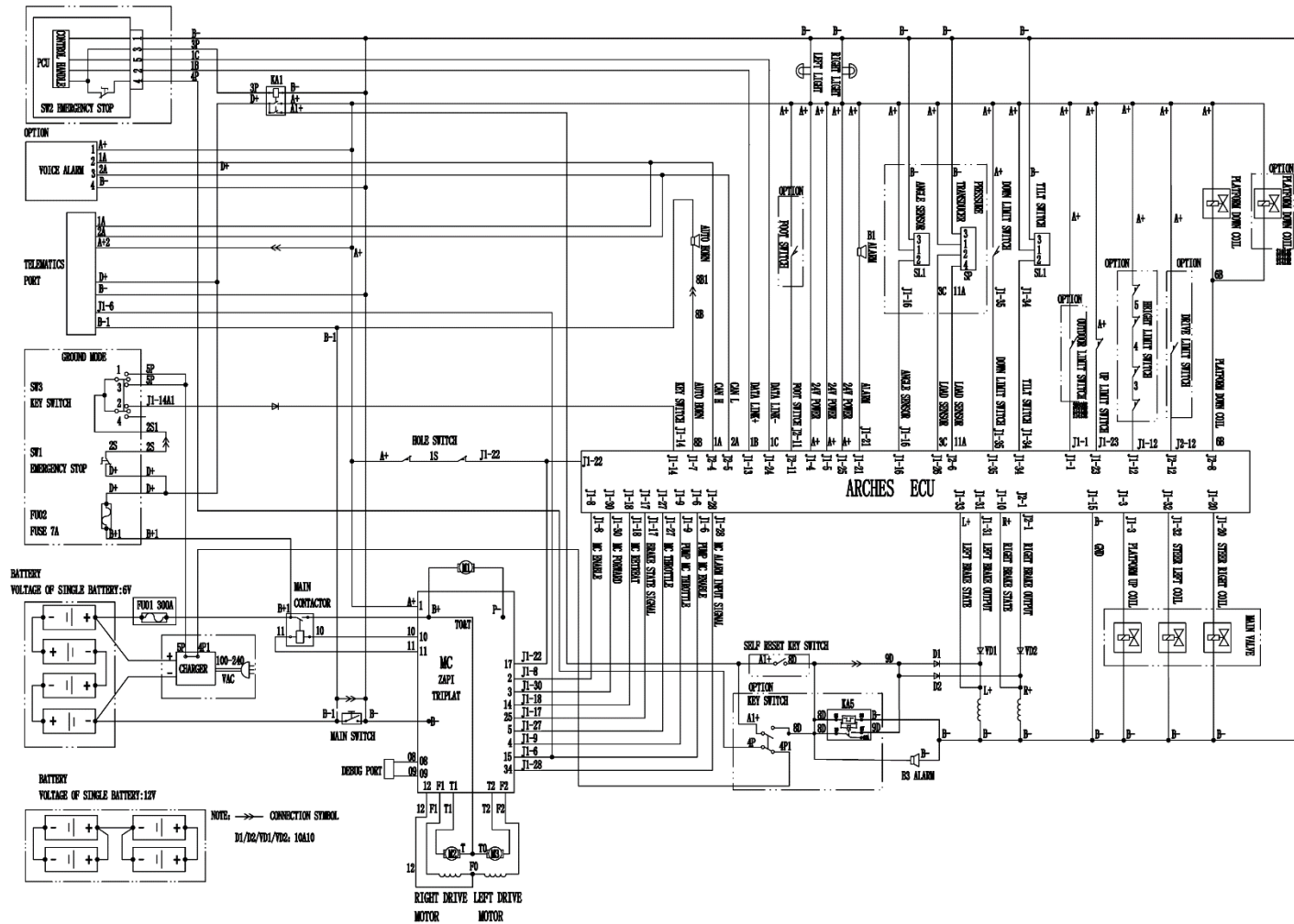

### 7.3.2 Electrical schematic diagram (hydraulic drive)

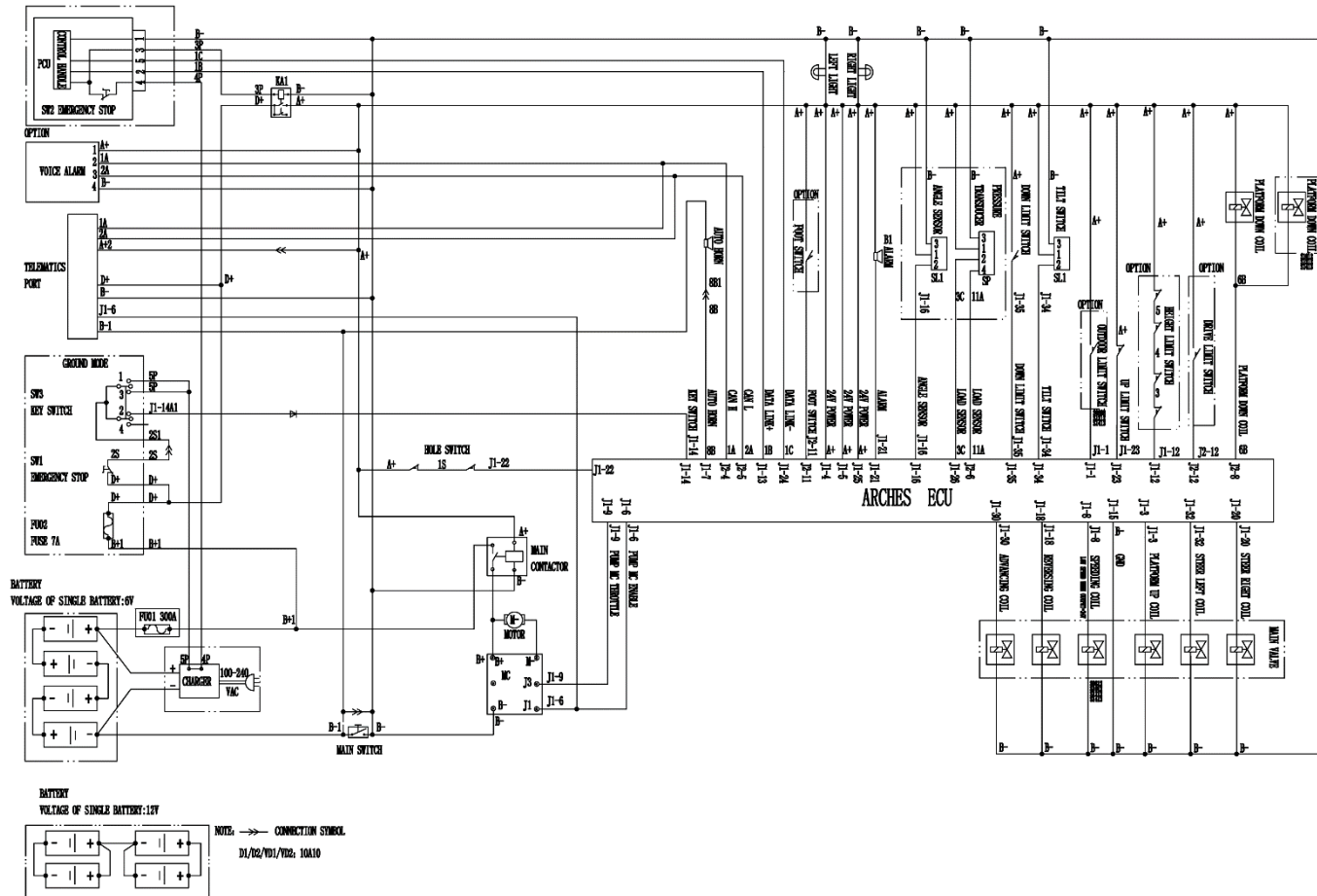

## 7.4 Main electrical components

### 7.4.1 Platform control unit (PCU)



Fig. 7.1 PCU

The PCU is used to operate the machine on the platform. When the function button is activated, the controller will send a signal to the electronic control module. When the electronic control is in function mode, the platform controller can be used to operate a variety of machine functions. The PCU includes an emergency stop button, control handle, alarm, internal wiring, function buttons and LED. See the figure above for the PCU:

Common faults of PCU:

- a) The handle is loose and the emergency stop switch is loose. In this case, tighten nuts to tighten them.
- b) Any plug of the PCU is faulty and any pins are commonly loose or bent. In this case, the pins or plugs can be replaced.

In case of internal wiring failure, please contact the Service Department of LGMG in time.

### 7.4.2 Platform control unit (PCU)

#### 1. Specifications and parameters of PCU

Name	Operating voltage (V)	Maximum current (mA)	Operating temperature (°C)	Waterproof grade
PCU-V8	24	200	-30 ~ +70 °C (operating temperature of handle and buzzer: -20 ~ +70 °C)	IP66

#### 2. Definition of PCU port

PIN	Type	Electrical characteristics	Function
1	Ground	1A	PCU power supply-
2	DATA LINK +	DATA LINK +	DATA LINK +
3	Power Input	8-32 VDC, 1 A	PCU power +
4	Power Output	8-32 VDC, 1 A	PCU power +
5	DATA LINK -	DATA LINK -	DATA LINK -

#### 3. PCU harness number

Plug pin position	1	2	3	4	5
Function	Ground	DATA LINK + (serial port)	Power Input	Power Output	DATA LINK - (serial port)
Color	White	Red	Yellow	Blue	Green
Line length (mm/in)	4000/157	4000/157	4000/157	4000/157	4000/157

### 7.4.3 Electrical control unit (ECU)



Fig. 7.2 ECU

- a. LCD
- B. Up button
- C. Return button
- D. Down button
- E. OK button
- F. Overload indicator light
- g. Platform up button
- h. Platform down button
- I. Enable button

The ECU (Electronic Control Unit), as the control center of the whole machine, can receive the signal input from the PCU and output relevant control. The ECU itself contains a function key mask and LCD, which can realize the current status display, parameter setting, status monitoring of key parameters, etc.

Function descriptions:

- 1) LCD: display the current status, etc.;
- 2) OK/Page Up/Page Down/Back: operate and set the LCD displayed information
- 3) Enabling/lifting/lowering: achieve the lifting and lowering of the whole machine

### 7.4.4 Electronic control unit (ECU)

#### 1. ECU specification parameter

Serial number	Status	Parameter
1	Supply voltage	9-32V
2	Operating temperature	-30°C ~ 70°C (liquid crystal -20°C ~ 70°C)
3	IP rating	IP67
4	Connector specification	TE 776231-1/776262-1
5	Communication interface	Serial port/CAN

#### 2. Typical port definition

Pin	Pin type	Pin features	Function
-----	----------	--------------	----------



J1-1	Input	24VDC	Reserved
J1-2	Input	24VDC	Reserved
J1-3	Output	24VDC/2.5A	Lifting valve control
J1-4	Power supply	24VDC/7A Power pin can undertake 3.5A	Valve drive power supply
J1-5	Power supply	24VDC/7A Power pin can undertake 3.5A	Valve drive power supply
J1-6	Output	24VDC/2.5A	Motor control unit enabling
J1-7	Output	24VDC/2.5A	Horn control
J1-8	Output	24VDC/2.5A	Walking motor enabling
J1-9	Output	0-5VDC /10mA	Motor speed control
J1-10	Input	24VDC	Right brake status
J1-11	Input	0-5 VDC/4-20mA	Reserved
J1-12	Input	24VDC	Reserved
J1-13	Communication	DATA LINK+	PCU communication+
J1-14	Input	24 VDC: PCU 0 VDC: GCU	Chassis key switch
J1-15	Power supply	0 VDC/2A	Working power supply grounded
J1-16	Input	0-5 VDC	Angle sensor
J1-17	Input	5 VDC, 0 V	Brake status signal
J1-18	Output	24VDC/2.5A	Back
J1-19	Output	0VDC/150mA	Reserved
J1-20	Output	24 VDC/2.5A	Right turn valve control
J1-21	Output	0 VDC/150mA	Buzzer control
J1-22	Input	24 VDC	Pothole switch
J1-23	Input	24 VDC	Upper limit switch
J1-24	Communication	DATA LINK-	PCU communication-
J1-25	Power supply	24 VDC/2A	Operating power supply
J1-26	Input	0-5 VDC/4-20mA	Pressure sensor 1
J1-27	Output	0-5 VDC/10mA	Walking motor speed control
J1-28	Input	5 VDC,0V active low	Motor driver alarm output
J1-29	Output	24 VDC/2.5A	Overload alarm lamp
J1-30	Output	24 VDC/2.5A	Forward
J1-31	Output	24 VDC/2.5A	Left brake release
J1-32	Output	24 VDC/2.5A	Left turn valve control
J1-33	Input	24 VDC	Left brake status
J1-34	Input	24 VDC	Inclination switch
J1-35	Input	24 VDC	Lower limit switch

Pin	Pin type	Pin features	Function
J2-1	Output	24 VDC/2.5A	Right brake release
J2-2	Input	0-5 VDC	Reserved
J2-3	Output	5 VDC/10mA	Reserved
J2-4	Communication	CAN2_H	CAN2_H
J2-5	Communication	CAN2_L	CAN2_L
J2-6	Input	4-20mA	Pressure sensor 2
J2-7	Input	4-20mA	Reserved
J2-8	Output - PWM	24 VDC/2.5mA	Lowering valve 2 control
J2-9	Output	24 VDC/2.5mA	Lowering valve 1 control
J2-10	Output	0-5 VDC/10mA	Reserved
J2-11	Input	24 VDC	Foot switch
J2-12	Input	24 VDC	Reserved
J2-13	Input	24 VDC	Reserved
J2-14	Output	24 VDC/2.5A	Reserved

### 7.4.5 Battery

The good condition of the battery is essential for normal machine performance and safe operation. Unsuitable electrolyte level or damaged cables and wiring may cause component damage and even dangerous conditions.

 CAUTION:

For machines with sealed batteries or maintenance-free batteries, the electrolyte level may not be checked, and other locations shall be checked.

 Danger of electric shock: live operation may lead to serious personal injury or death. Remove all rings, watches and other jewelry before operation.

 Danger of physical injury: battery electrolyte has corrosiveness. Prevent hands or other parts of the body from contacting with spilled electrolyte to avoid injury. Use baking soda to neutralize the spilled electrolyte.

 CAUTION: Check the battery and pay attention to the following:

- Wear protective clothing and protective glasses.
- Ensure that the wiring of the battery cable is firm and not corroded.
- Ensure that the battery lock lever is secure.

 CAUTION: the addition of terminal protector and anti-corrosion sealant will help to eliminate corrosion of battery terminal and cables.

#### 1. Judgment of battery charging status

It will be shown on the display of the PCU in normal operating condition.

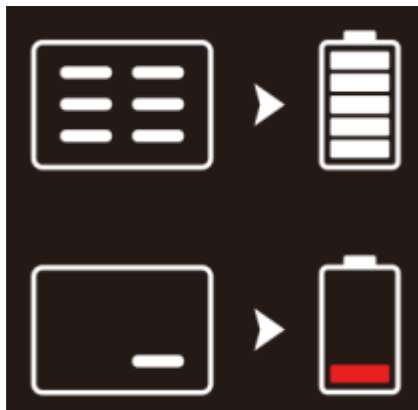

Fig. 7.3 Battery Level Display



**CAUTION:** For specific battery charging operation steps, please refer to the

operation and maintenance manual of the lifting platform from LGMG. If you want to know more about the charging operation, please contact the After-sales Service Department of LGMG.

## 2. Common faults and troubleshooting of battery

Battery voltage test (only used to determine that the battery needs to be replaced)

### 1) Voltage test during charging

Disconnect and reconnect the DC plug to restart the charger; When charging the battery, please record the current during the last half hour of charging (if possible) and measure the voltage of the battery pack; If the current is below 5A at the end of charging and the voltage of the battery pack is above the following values: 56V for 48V system, 42V for 36V system, 28V for 24V system, 14V for 12V battery, 9.3V for 8V battery and 7V for 6V battery, then proceed to the next step. Otherwise, check whether the output of the charger is correct and recharge the battery as needed. If the voltage of the battery pack is still low, the battery may be faulty. When the battery is in the charging state, please measure the voltage of each battery; If the voltage of any battery is below the following values: 7 V for a 6 V battery, 9.3 V for an 8 V battery, and 14 V for a 12 V battery, and if a voltage difference between the battery and any other battery in the battery pack is greater than 0.5 V for a 6 V battery, or this voltage difference is greater than 1.0 V for a 12 V battery, then this battery may be faulty.

### 2) Specific gravity test (flooded/wet battery only)

Please top up and drain the hydrometer two or three times, and then take a sample from the battery to measure the specific gravity reading of all battery cells; When it is above 80 degrees Fahrenheit (27 degrees Celsius), 0.004 is added to correct the specific gravity reading for each increment of 10 degrees Fahrenheit (5 degrees Celsius); When it is below 80 degrees Fahrenheit (27 degrees Celsius), 0.004 is subtracted to correct the specific gravity reading for each decrement of 10 degrees Fahrenheit (5 degrees Celsius); If each battery cell in the battery pack is below 1.250, this battery pack may be undercharged; in this case, please recharge it; If the specific gravity difference between any battery cells in the battery pack exceeds 0.050, perform equalization on this battery pack; If there is still a discrepancy, there may be a faulty cell in the battery pack.

### 3) Discharge test

Connect and start the discharger, record the running time in minutes when the discharge is

completed, and use the following formula to correct the number of minutes of running time for temperature (valid between 24°C and 32°C):  $M_c = M_r[1-0.009(T-27)]$ , where  $M_c$  is the corrected number of minutes,  $M_r$  is the recorded number of minutes, and  $T$  is the temperature expressed in °C at the end of the discharge. If the discharge time is greater than 50% of the battery rating, then all batteries can be used; Reconnect the discharger to record the voltage (current drain) while each battery is still under load. If the discharge operation time is less than 50% of the battery rating, a battery with a voltage 0.5 V lower than the maximum voltage may be faulty.

Fault	Symptom	Possible cause	Handling method
External fault	Damage	Pole corrosion, pole loosening, shell crack, liquid leakage	Repair and replace as appropriate
Polar plate vulcanization	<ol style="list-style-type: none"> <li>White, hard and insoluble coarse grain lead sulfate is formed on the surface</li> <li>The battery has poor charging acceptance and its voltage rises rapidly during charging.</li> <li>Its voltage decreases rapidly during discharge, and its capacity is obviously lower than that of other normal batteries.</li> </ol>	<ol style="list-style-type: none"> <li>Insufficient battery charge for a long time</li> <li>Failure to charge it in time after discharging</li> <li>Frequent overcharge or low current deep discharge</li> <li>The electrolyte is impure and the self discharge is excessive</li> <li>Internal short circuit or excessive water on the battery surface causes electric leakage</li> <li>Low electrolyte level inside the battery, vulcanizing the exposed part of the polar plate</li> </ol>	Batteries that are not severely vulcanized can be treated by the equalization charging method, and subjected to repeated charge and discharge cycles (full charge and full discharge); Seriously vulcanized batteries need to be replaced
Battery open circuit	It cannot be charged, and there is no current display. In severe cases, this is accompanied by internal sparking of the battery	<ol style="list-style-type: none"> <li>The pole is damaged and cracked</li> <li>False welding</li> </ol>	Replace
Battery short circuit	<ol style="list-style-type: none"> <li>Low voltage</li> <li>Insufficient capacity</li> <li>The voltage is still lower than the normal value after charging.</li> </ol>	<ol style="list-style-type: none"> <li>Short circuit due to lead leakage or broken diaphragm</li> <li>The electrolyte is impure and impurities are crystallized, which causes short circuit due to seriously detached active substances of polar plate accumulated at the bottom of the battery tank</li> </ol>	Replace

## 7.5 Harness

### 7.5.1 Table of S1932E II main harness wiring diagram and wire number

Wiring diagram:

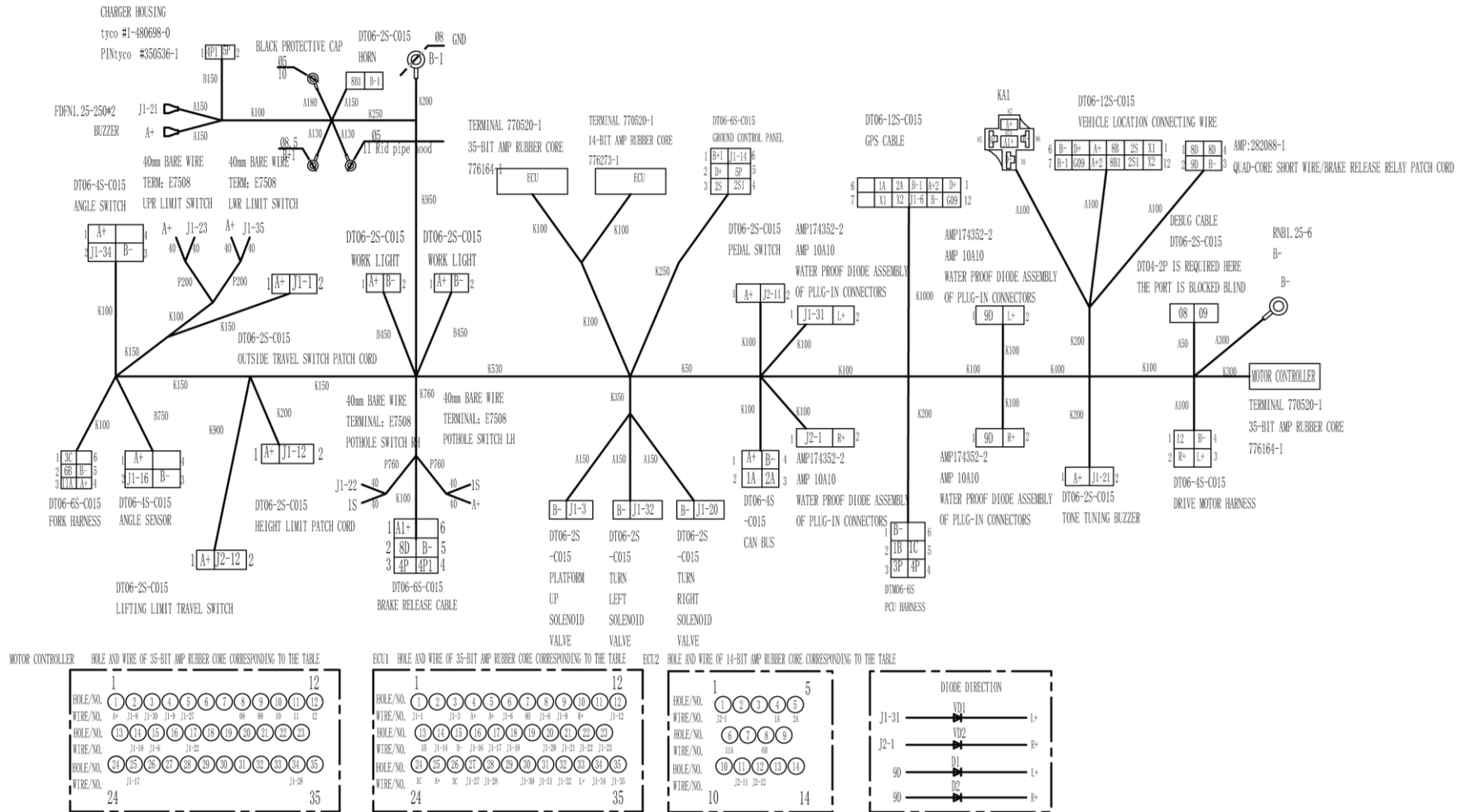

## Line number description:

Wire size	Name	Wire color	Wire size	Name	Wire color
9D	Emergency brake release switch signal line	White	8B1	Horn power cord	White
J2-12	Lifting limit ground wire	Red	B-1	Battery negative terminal	Black
J1-21	Buzzer ground wire	Black	A+2	Control signal positive	White
J1-9	Pump motor control speed adjustment	White	G09	GPS horn control signal	White
J1-8	Motor control walking enabling	White	1A	CAN H	White
8B	Horn power cord	Red	2A	CAN L	White
J1-6	Pump motor control enabling	White	X2	Reserved hole position	White
J1-20	Right turn solenoid valve power cord	Red	X1	Reserved hole position	White
J1-32	Left turn solenoid valve power cord	Red	B+1	Power cord	Red
J1-18	Motor control reverse	White	B-	Ground wire	Black
J1-30	Motor control forward	White	A+	Power cord	Red
6B	Platform lowering solenoid valve power cord	White	J1-35	Signal line of lower limit switch	White
J1-3	Platform lifting solenoid valve power cord	Red	J1-34	Signal line of inclination switch	White
5P	Platform control panel to charger	White	J1-23	Upper limit switch signal line	White
J1-28	Motor control unit alarm input signal	White	J1-22	Pothole protection signal line	White
J1-17	Brake status signal line	White	R+	Right brake status signal line	White
4P/4P1	Charger power cord to PCU	Red	L+	Left brake status signal line	White
J1-27	Motor control walking speed adjustment	White	J1-12	Platform height limit ground wire	White
J1-16	Angle sensor signal line	White	J1-1	Outdoor height travel switch ground wire	White
3C	Pressure sensor signal line	White	J2-1	Right brake coil power cord	Red
J1-14	Key switch signal	Red	J1-31	Left brake coil power cord	Red
1S	Left and right pothole protection switch transition line	White	D+	Power cord	Red
1C	DATA LINK-	Black	09	Motor control unit CANH	White
1B	DATA LINK+	Red	08	Motor control unit CANL	White
12	Drive motor excitation coil signal line	White	11A	Relay KA4	White
11	Main contactor coil power cord	Red	8D	Delay switch signal line	White
10	Master contactor coil ground wire	Black	A1+	Emergency brake release switch	White
3P	Relay KA1	White	J2-11	Pedal ground wire	White

### 7.5.2 S2632E II , S46EII Main harness wiring diagram and wire size table

Wiring diagram:

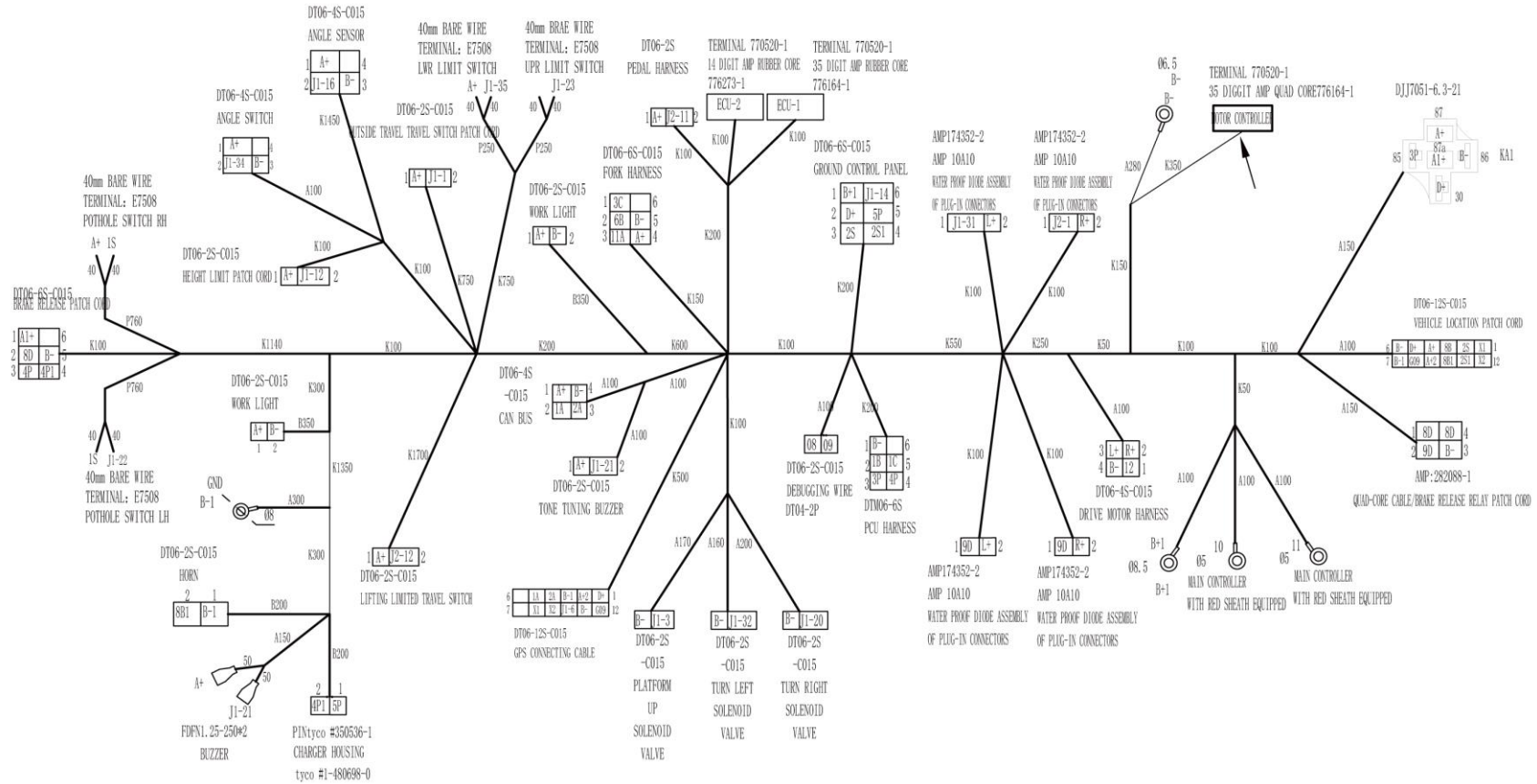

MOTOR CONTROLLER HOLE AND WIRE OF 35-BIT AMP RUBBER CORE CORRESPONDING TO THE TABLE

HOLE/NO.	1	2	3	4	5	6	7	8	9	10	11	12
WIRE/NO.	11-1	11-2	11-3	11-4	11-5	11-6	11-7	11-8	11-9	11-10	11-11	11-12
HOLE/NO.	13	14	15	16	17	18	19	20	21	22	23	
WIRE/NO.	11-13	11-14	11-15	11-16	11-17	11-18	11-19	11-20	11-21	11-22	11-23	
HOLE/NO.	24	25	26	27	28	29	30	31	32	33	34	35
WIRE/NO.	11-24	11-25	11-26	11-27	11-28	11-29	11-30	11-31	11-32	11-33	11-34	11-35

ECU1 HOLE AND WIRE OF 35-BIT AMP RUBBER CORE CORRESPONDING TO THE TABLE

HOLE/NO.	1	2	3	4	5	6	7	8	9	10	11	12
WIRE/NO.	11-1	11-2	11-3	11-4	11-5	11-6	11-7	11-8	11-9	11-10	11-11	11-12
HOLE/NO.	13	14	15	16	17	18	19	20	21	22	23	
WIRE/NO.	11-13	11-14	11-15	11-16	11-17	11-18	11-19	11-20	11-21	11-22	11-23	
HOLE/NO.	24	25	26	27	28	29	30	31	32	33	34	35
WIRE/NO.	11-24	11-25	11-26	11-27	11-28	11-29	11-30	11-31	11-32	11-33	11-34	11-35

ECU2 HOLE AND WIRE OF 35-BIT AMP RUBBER CORE CORRESPONDING TO THE TABLE

HOLE/NO.	1	2	3	4	5
WIRE/NO.	11-1	11-2	11-3	11-4	11-5
HOLE/NO.	6	7	8	9	
WIRE/NO.	11-6	11-7	11-8	11-9	
HOLE/NO.	10	11	12	13	14
WIRE/NO.	11-10	11-11	11-12	11-13	11-14

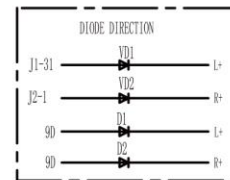

Line number description:

Wire size	Name	Wire color	Wire size	Name	Wire color
9D	Emergency brake release switch signal line	White	8B1	Horn power cord	White
J2-12	Lifting limit ground wire	Red	B-1	Battery negative terminal	Black
J1-21	Buzzer ground wire	Black	A+2	Control signal positive	White
J1-9	Pump motor control speed adjustment	White	G09	GPS horn control signal	White
J1-8	Motor control walking enabling	White	1A	CAN H	White
8B	Horn power cord	Red	2A	CAN L	White
J1-6	Pump motor control enabling	White	X2	Reserved hole position	White
J1-20	Right turn solenoid valve power cord	Red	X1	Reserved hole position	White
J1-32	Left turn solenoid valve power cord	Red	B+1	Power cord	Red
J1-18	Motor control reverse	White	B-	Ground wire	Black
J1-30	Motor control forward	White	A+	Power cord	Red
6B	Platform lowering solenoid valve power cord	White	J1-35	Signal line of lower limit switch	White
J1-3	Platform lifting solenoid valve power cord	Red	J1-34	Signal line of inclination switch	White
5P	Platform control panel to charger	White	J1-23	Upper limit switch signal line	White
J1-28	Motor control unit alarm input signal	White	J1-22	Pothole protection signal line	White
J1-17	Brake status signal line	White	R+	Right brake status signal line	White
4P/4P1	Charger power cord to PCU	Red	L+	Left brake status signal line	White
J1-27	Motor control walking speed adjustment	White	J1-12	Platform height limit ground wire	White
J1-16	Angle sensor signal line	White	J1-1	Outdoor height travel switch ground wire	White
3C	Pressure sensor signal line	White	J2-1	Right brake coil power cord	Red
J1-14	Key switch signal	Red	J1-31	Left brake coil power cord	Red
1S	Left and right pothole protection switch transition line	White	D+	Power cord	Red
1C	DATA LINK-	Black	09	Motor control unit CANH	White
1B	DATA LINK+	Red	08	Motor control unit CANL	White
12	Drive motor excitation coil signal line	White	11A	Relay KA4	White
11	Main contactor coil power cord	Red	8D	Delay switch signal line	White
10	Master contactor coil ground wire	Black	A1+	Emergency brake release switch	White
3P	Relay KA1	White	J2-11	Pedal ground wire	White



### 7.5.3 S4650E II Main harness wiring diagram and wire size table

Wiring diagram:

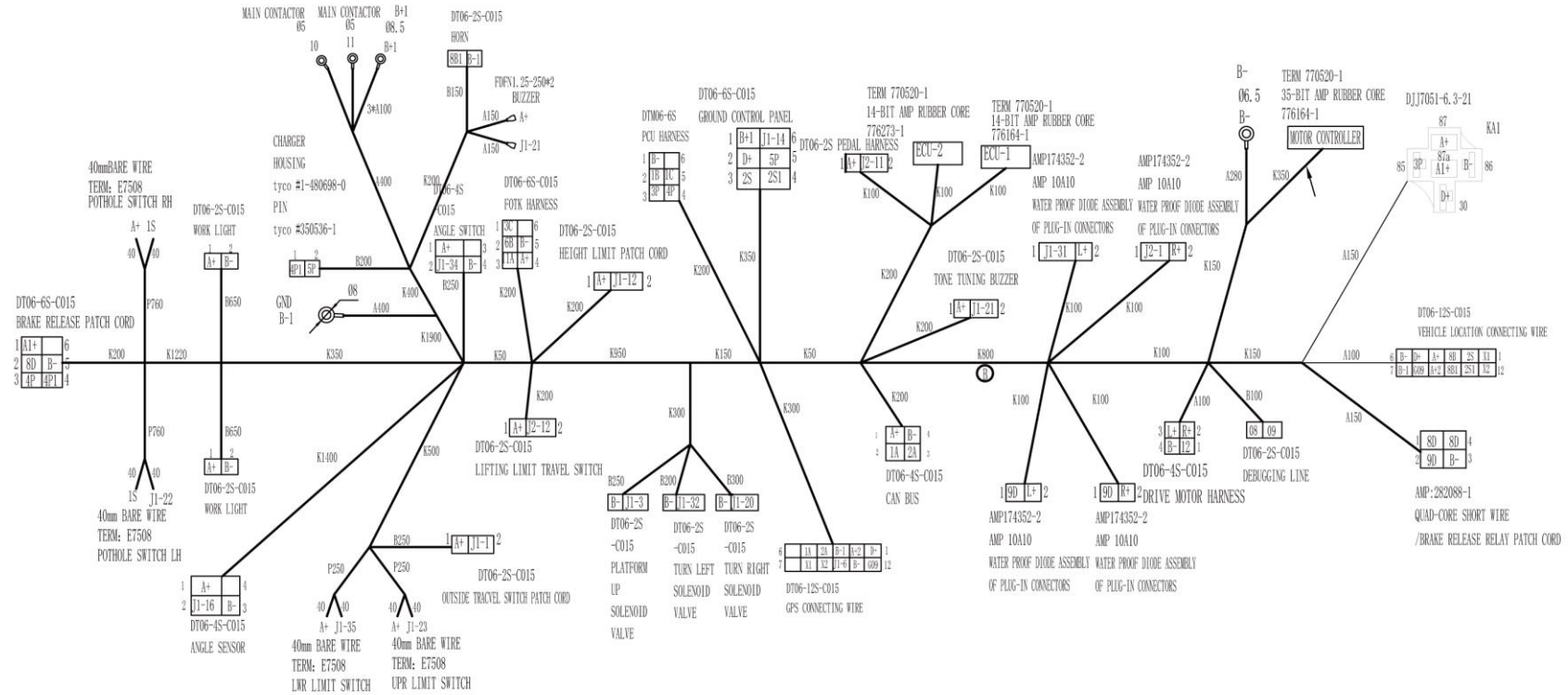

MOTOR CONTROLLER HOLE AND WIRE OF 35-BIT AMP RUBBER CORE CORRESPONDING TO THE TABLE

HOLE/NO.	1	2	3	4	5	6	7	8	9	10	11	12	
WIRE/NO.	34	31-8	31-30	31-9	31-27	30	30	30	31	32	24	25	26
HOLE/NO.	13	14	15	16	17	18	19	20	21	22	23		
WIRE/NO.	31-18	31-4	31-22										
HOLE/NO.	24	25	26	27	28	29	30	31	32	33	34	35	
WIRE/NO.	31-17		31-28										
	24	35											

ECU1 HOLE AND WIRE OF 35-BIT AMP RUBBER CORE CORRESPONDING TO THE TABLE

HOLE/NO.	1	2	3	4	5	6	7	8	9	10	11	12
WIRE/NO.	31-3	31-4	31-4	31-4	31-4	31-9	31-9	31-9	31-9	31-9	31-9	31-9
HOLE/NO.	13	14	15	16	17	18	19	20	21	22	23	
WIRE/NO.	31-14	31-6	31-16	31-17	31-18	31-30	31-21	31-22	31-23			
HOLE/NO.	24	25	26	27	28	29	30	31	32	33	34	35
WIRE/NO.	31-30	31-30	31-27	31-28	31-30	31-31	31-32	31-31	31-31	31-31	31-31	31-31
	24	35										

ECU2 HOLE AND WIRE OF 14-BIT AMP RUBBER CORE CORRESPONDING TO THE TABLE

HOLE/NO.	1	2	3	4	5
WIRE/NO.	31-2	31-2	31-2	31-2	31-2
HOLE/NO.	6	7	8	9	
WIRE/NO.	31-11	31-11	31-11	31-11	31-11
HOLE/NO.	10	11	12	13	14
WIRE/NO.	31-11				
	10	14			



Line number description:

Wire size	Name	Wire color	Wire size	Name	Wire color
9D	Emergency brake release switch signal line	White	8B1	Horn power cord	White
J2-12	Lifting limit ground wire	Red	B-1	Battery negative terminal	Black
J1-21	Buzzer ground wire	Black	A+2	Control signal positive	White
J1-9	Pump motor control speed adjustment	White	G09	GPS horn control signal	White
J1-8	Motor control walking enabling	White	1A	CAN H	White
8B	Horn power cord	Red	2A	CAN L	White
J1-6	Pump motor control enabling	White	X2	Reserved hole position	White
J1-20	Right turn solenoid valve power cord	Red	X1	Reserved hole position	White
J1-32	Left turn solenoid valve power cord	Red	B+1	Power cord	Red
J1-18	Motor control reverse	White	B-	Ground wire	Black
J1-30	Motor control forward	White	A+	Power cord	Red
6B	Platform lowering solenoid valve power cord	White	J1-35	Signal line of lower limit switch	White
J1-3	Platform lifting solenoid valve power cord	Red	J1-34	Signal line of inclination switch	White
5P	Platform control panel to charger	White	J1-23	Upper limit switch signal line	White
J1-28	Motor control unit alarm input signal	White	J1-22	Pothole protection signal line	White
J1-17	Brake status signal line	White	R+	Right brake status signal line	White
4P/4P1	Charger power cord to PCU	Red	L+	Left brake status signal line	White
J1-27	Motor control walking speed adjustment	White	J1-12	Platform height limit ground wire	White
J1-16	Angle sensor signal line	White	J1-1	Outdoor height travel switch ground wire	White
3C	Pressure sensor signal line	White	J2-1	Right brake coil power cord	Red
J1-14	Key switch signal	Red	J1-31	Left brake coil power cord	Red
1S	Left and right pothole protection switch transition line	White	D+	Power cord	Red
1C	DATA LINK-	Black	09	Motor control unit CANH	White
1B	DATA LINK+	Red	08	Motor control unit CANL	White
12	Drive motor excitation coil signal line	White	11A	Relay KA4	White
11	Main contactor coil power cord	Red	8D	Delay switch signal line	White
10	Master contactor coil ground wire	Black	A1+	Emergency brake release switch	White
3P	Relay KA1	White	J2-11	Pedal ground wire	White

### 7.5.4 S1932 II Main harness wiring diagram and wire size table

Wiring diagram:

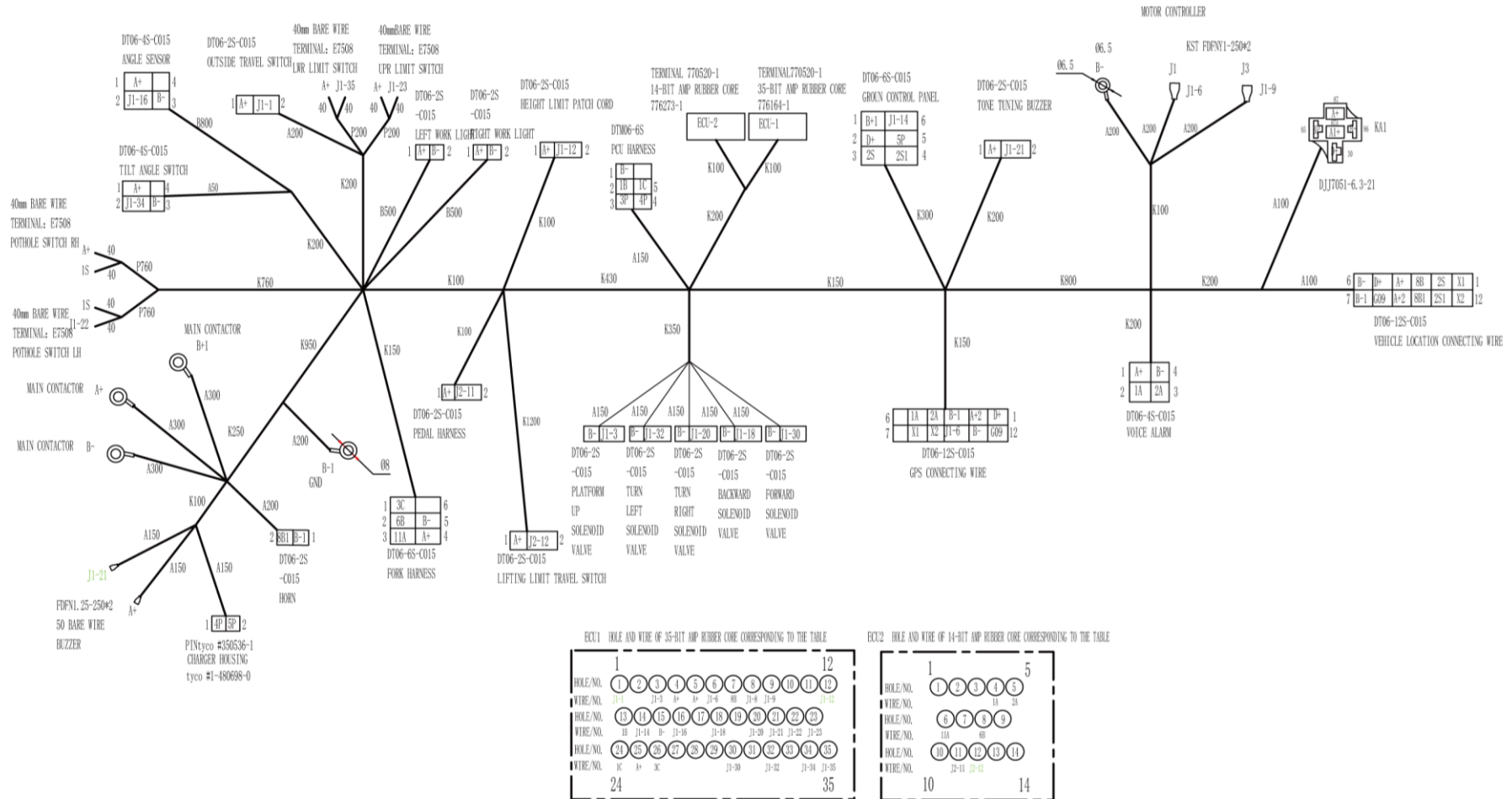

Line number description:

Wire size	Name	Wire color	Wire size	Name	Wire color
D+	Power cord	Red	8B1	Horn power cord	White
A+	Power cord	Red	B-1	Battery negative terminal	Black
J1-21	Buzzer ground wire	Black	A+2	Control signal positive	White
J1-9	Pump motor control speed adjustment	White	G09	GPS horn control signal	White
J1-8	Speed valve signal	White	1A	CAN H	White
8B	Horn power cord	Red	2A	CAN L	White
J1-6	Pump motor control enabling	White	B+1	Power cord	Red
J1-20	Right turn solenoid valve power cord	Red	B-	Ground wire	Black
J1-32	Left turn solenoid valve power cord	Red	J1-22	Pothole protection signal line	White
J1-30	Motor control forward	White	J1-35	Signal line of lower limit switch	White
J1-18	Motor control reverse	White	J1-34	Signal line of inclination switch	White
6B	Platform lowering solenoid valve power cord	White	J1-23	Upper limit switch signal line	White
J1-3	Platform lifting solenoid valve power cord	Red	2S	Key switch signal line	Red
5P	Platform control panel to charger	White	2S1	Key switch signal line	Red
11A	Pressure sensor signal line	White	X1	Reserved hole position	White
4P	Charger power cord to PCU	Red	X2	Reserved hole position	White
J1-16	Angle sensor signal line	White	J1-1	Outdoor height travel switch ground wire	Black
3C	Pressure sensor signal line	White	B-	Ground wire	Black
J1-14	Key switch signal	Red	J2-12	Lifting limit ground wire	Black
1S	Left and right pothole protection switch transition line	White	J1-12	Platform height limit ground wire	Black
1C	DATA LINK-	Black	J2-11	Pedal ground wire	Black
1B	DATA LINK+	Red	11A	Pressure sensor signal line	White
3P	Relay KA1	White			

### 7.5.5 S2632 II , S46 II Main harness wiring diagram and wire size table

Wiring diagram:

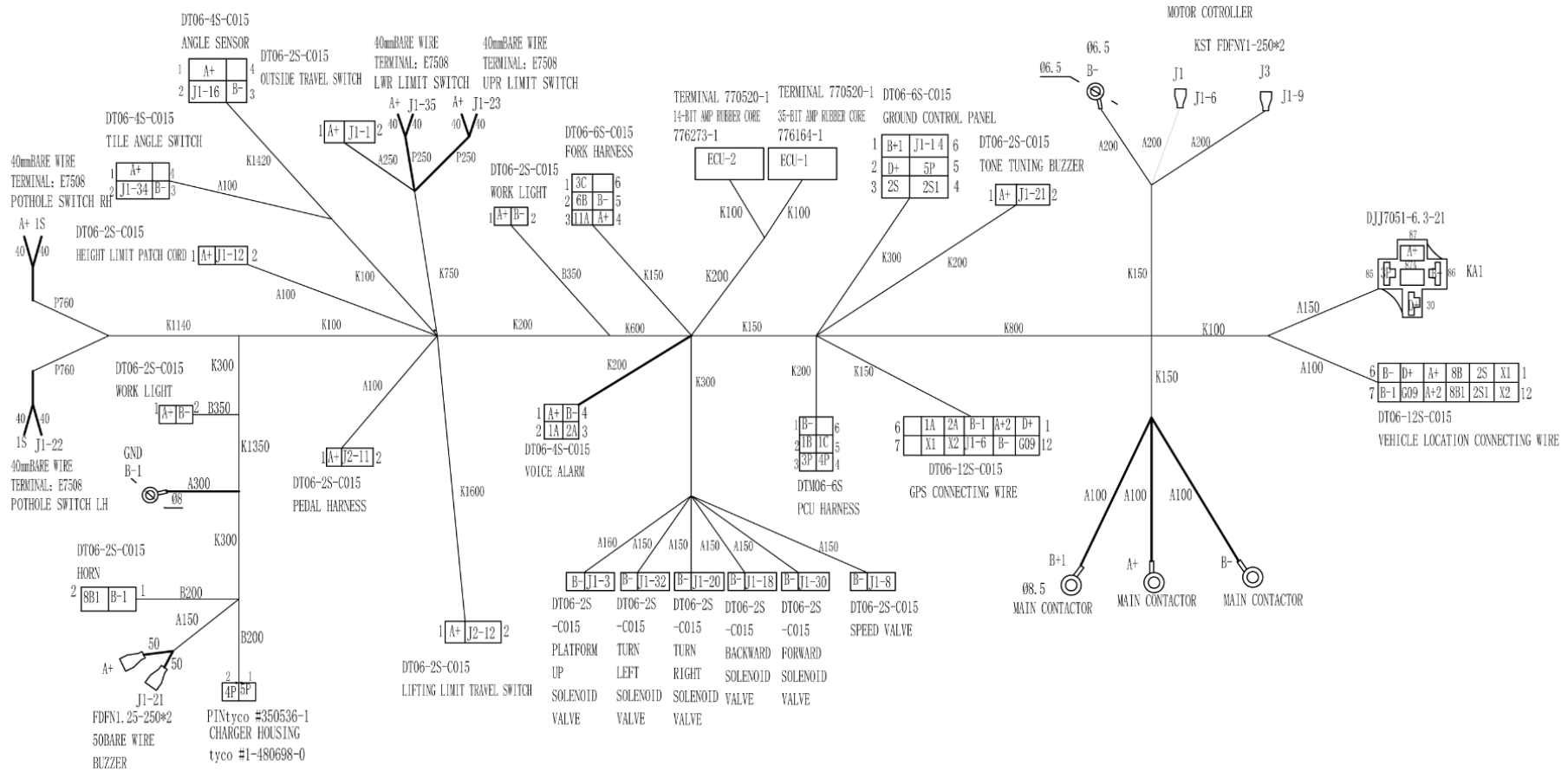

ECU1 HOLE AND WIRE OF 35-BIT AMP RUBBER CORE CORRESPONDING TO THE TABLE

HOLE/NO.	1	2	3	4	5	6	7	8	9	10	11	12
WIRE/NO.	J1-3	A+	A+	J1-6	88	J1-8	J1-9					
HOLE/NO.	13	14	15	16	17	18	19	20	21	22	23	
WIRE/NO.	16	J1-14	B-	J1-16	J1-18	J1-20	J1-21	J1-22	J1-23			
HOLE/NO.	24	25	26	27	28	29	30	31	32	33	34	35
WIRE/NO.	1C	A+	3C		J1-30	J1-32	J1-34	J1-35				
	24											35

ECU2 HOLE AND WIRE OF 14-BIT AMP RUBBER CORE CORRESPONDING TO THE TABLE

HOLE/NO.	1	2	3	4	5
WIRE/NO.	11	21	31	41	51
HOLE/NO.	6	7	8	9	
WIRE/NO.	11A	66			
HOLE/NO.	10	11	12	13	14
WIRE/NO.	J2-11				
	10				14

Line number description:

Wire size	Name	Wire color	Wire size	Name	Wire color
D+	Power cord	Red	8B1	Horn power cord	White
A+	Power cord	Red	B-1	Battery negative terminal	Black
J1-21	Buzzer ground wire	Black	A+2	Control signal positive	White
J1-9	Pump motor control speed adjustment	White	G09	GPS horn control signal	White
J1-8	Speed valve signal	White	1A	CAN H	White
8B	Horn power cord	Red	2A	CAN L	White
J1-6	Pump motor control enabling	White	B+1	Power cord	Red
J1-20	Right turn solenoid valve power cord	Red	B-	Ground wire	Black
J1-32	Left turn solenoid valve power cord	Red	J1-22	Pothole protection signal line	White
J1-30	Motor control forward	White	J1-35	Signal line of lower limit switch	White
J1-18	Motor control reverse	White	J1-34	Signal line of inclination switch	White
6B	Platform lowering solenoid valve power cord	White	J1-23	Upper limit switch signal line	White
J1-3	Platform lifting solenoid valve power cord	Red	2S	Key switch signal line	Red
5P	Platform control panel to charger	White	2S1	Key switch signal line	Red
11A	Pressure sensor signal line	White	X1	Reserved hole position	White
4P	Charger power cord to PCU	Red	X2	Reserved hole position	White
J1-16	Angle sensor signal line	White	J1-1	Outdoor height travel switch ground wire	Black
3C	Pressure sensor signal line	White	B-	Ground wire	Black
J1-14	Key switch signal	Red	J2-12	Lifting limit ground wire	Black
1S	Left and right pothole protection switch transition line	White	J1-12	Platform height limit ground wire	Black
1C	DATA LINK-	Black	J2-11	Pedal ground wire	Black
1B	DATA LINK+	Red	11A	Pressure sensor signal line	White
3P	Relay KA1	White			

### 7.5.6 S4650 II Main harness wiring diagram and wire size table

Wiring diagram:

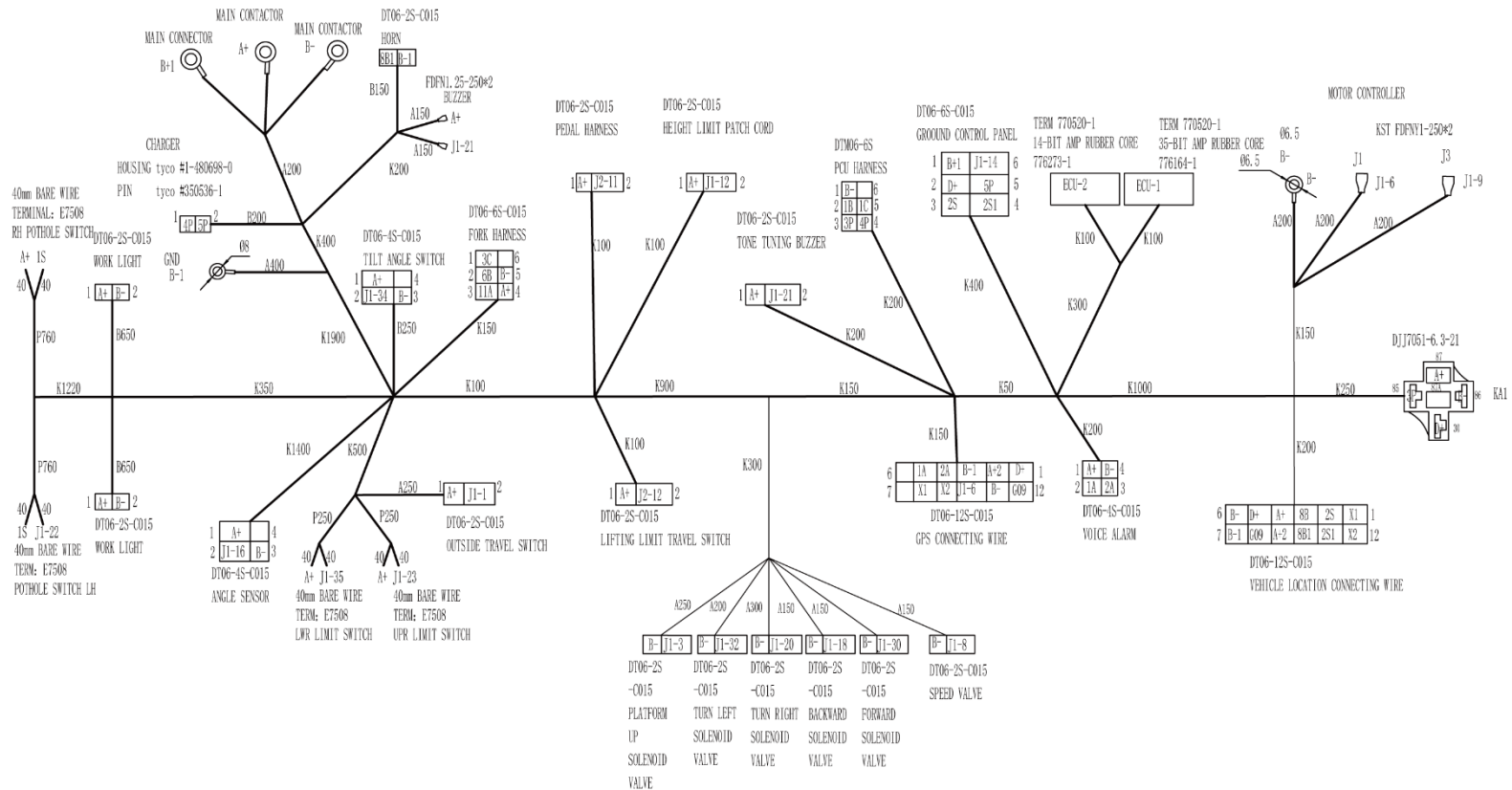

ECU1 HOLE AND WIRE OF 35-BIT AMP RUBBER CORE CORRESPONDING TO THE TABLE

HOLE/NO.	1	2	3	4	5	6	7	8	9	10	11	12
WIRE/NO.	J1-1	J1-3	A+	A+	J1-4	B-	J1-8	J1-9	J1-11	J1-12	J1-13	J1-14
HOLE/NO.	13	14	15	16	17	18	19	20	21	22	23	24
WIRE/NO.	B-	J1-15	B-	J1-16	J1-18	J1-20	J1-21	J1-22	J1-23	J1-24	J1-25	J1-26
HOLE/NO.	24	25	26	27	28	29	30	31	32	33	34	35
WIRE/NO.	1C	A+	A+	A+	J1-30	J1-32	J1-34	J1-35	J1-36	J1-37	J1-38	J1-39
	24											35

ECU2 HOLE AND WIRE OF 14-BIT AMP RUBBER CORE CORRESPONDING TO THE TABLE

HOLE/NO.	1	2	3	4	5
WIRE/NO.	1A	2A	3A	4A	5A
HOLE/NO.	6	7	8	9	
WIRE/NO.	11A	12A	13A	14A	
HOLE/NO.	10	11	12	13	14
WIRE/NO.	J1-11	J1-12	J1-13	J1-14	J1-15
	10				14

## Line number description:

Wire size	Name	Wire color	Wire size	Name	Wire color
D+	Power cord	Red	8B1	Horn power cord	White
A+	Power cord	Red	B-1	Battery negative terminal	Black
J1-21	Buzzer ground wire	Black	A+2	Control signal positive	White
J1-9	Pump motor control speed adjustment	White	G09	GPS horn control signal	White
J1-8	Speed valve signal	White	1A	CAN H	White
8B	Horn power cord	Red	2A	CAN L	White
J1-6	Pump motor control enabling	White	B+1	Power cord	Red
J1-20	Right turn solenoid valve power cord	Red	B-	Ground wire	Black
J1-32	Left turn solenoid valve power cord	Red	J1-22	Pothole protection signal line	White
J1-30	Motor control forward	White	J1-35	Signal line of lower limit switch	White
J1-18	Motor control reverse	White	J1-34	Signal line of inclination switch	White
6B	Platform lowering solenoid valve power cord	White	J1-23	Upper limit switch signal line	White
J1-3	Platform lifting solenoid valve power cord	Red	2S	Key switch signal line	Red
5P	Platform control panel to charger	White	2S1	Key switch signal line	Red
11A	Pressure sensor signal line	White	X1	Reserved hole position	White
4P	Charger power cord to PCU	Red	X2	Reserved hole position	White
J1-16	Angle sensor signal line	White	J1-1	Outdoor height travel switch ground wire	Black
3C	Pressure sensor signal line	White	B-	Ground wire	Black
J1-14	Key switch signal	Red	J2-12	Lifting limit ground wire	Black
1S	Left and right pothole protection switch transition line	White	J1-12	Platform height limit ground wire	Black
1C	DATA LINK-	Black	J2-11	Pedal ground wire	Black
1B	DATA LINK+	Red	11A	Pressure sensor signal line	White
3P	Relay KA1	White			



### 7.5.7 S1932 II and S1932E II PCU harness and fork harness

PCU harness wiring diagram:

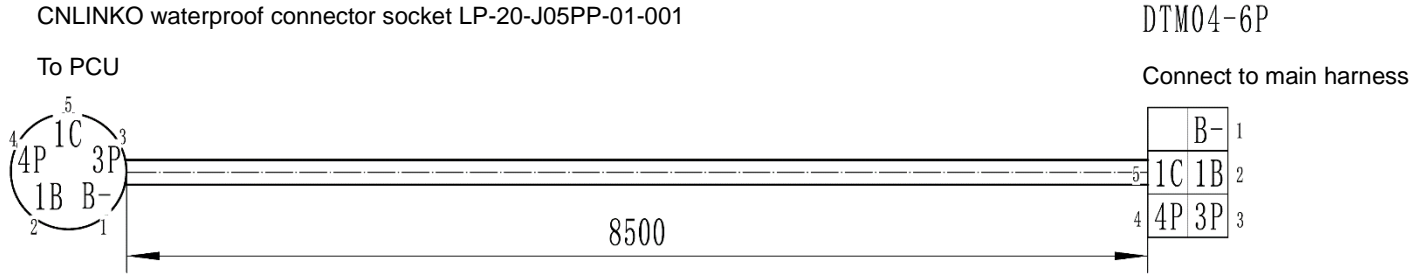

Wire size	Wire color
1B	Red
1C	Green
B-	White
3P	Yellow
4P	Blue

Fork harness wiring diagram

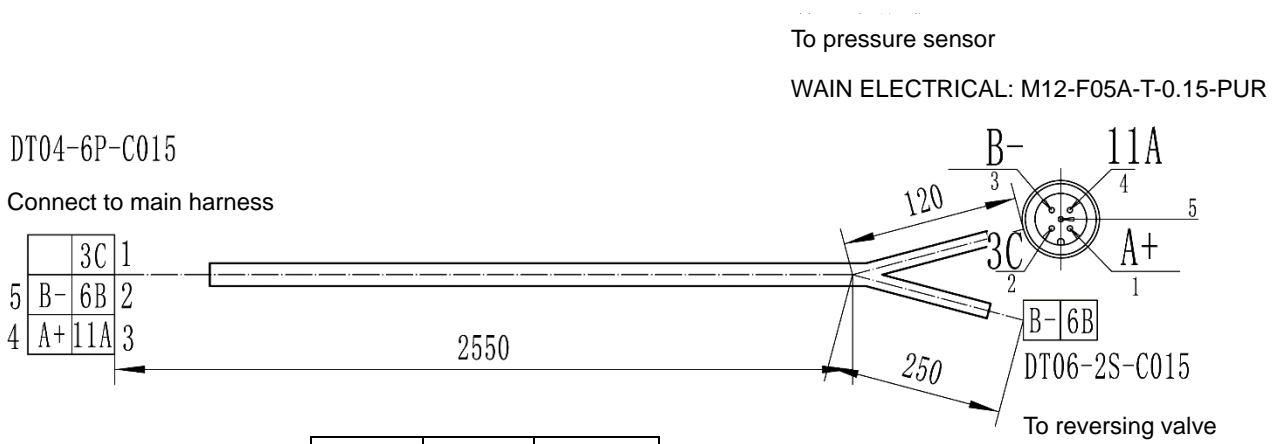

Wire size	color	Wire diameter
B-	Blue	0.85mm <sup>2</sup>
A+	Brown	0.85mm <sup>2</sup>
3C	White	0.85mm <sup>2</sup>
6B	White	0.85mm <sup>2</sup>
11A	Black	0.85mm <sup>2</sup>

7.5.8 S2632 II , S2632E II PCU harness and fork harness

PCU harness wiring diagram:

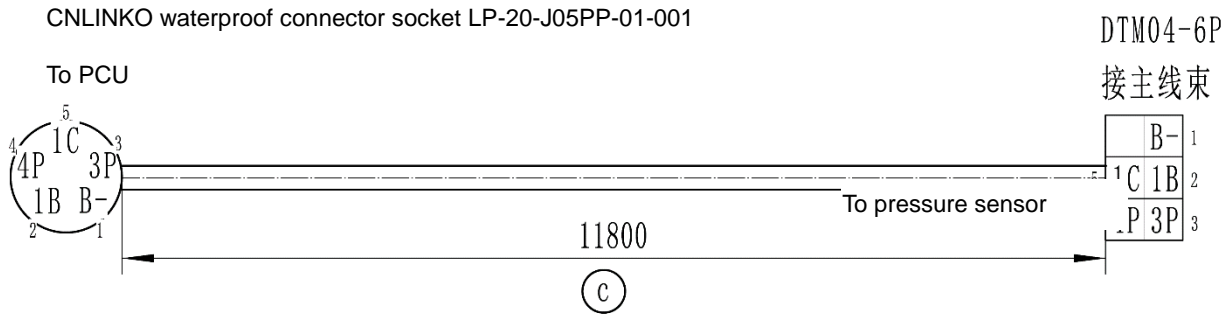

Wire size	Wire color
1B	Red
1C	Green
B-	White
3P	Yellow
4P	Blue

Fork harness wiring diagram:

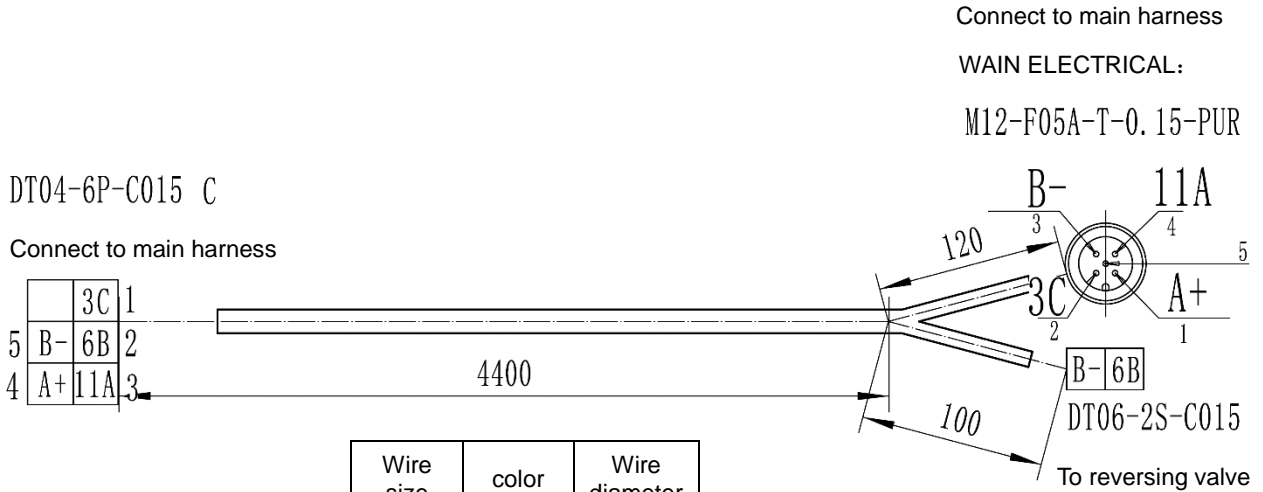

Wire size	color	Wire diameter
B-	Blue	0.85mm <sup>2</sup>
A+	Brown	0.85mm <sup>2</sup>
3C	White	0.85mm <sup>2</sup>
6B	White	0.85mm <sup>2</sup>
11A	Black	0.85mm <sup>2</sup>

7.5.9 S2646 II , S2646 E II PCU harness and fork harness

PCU harness connection diagram:

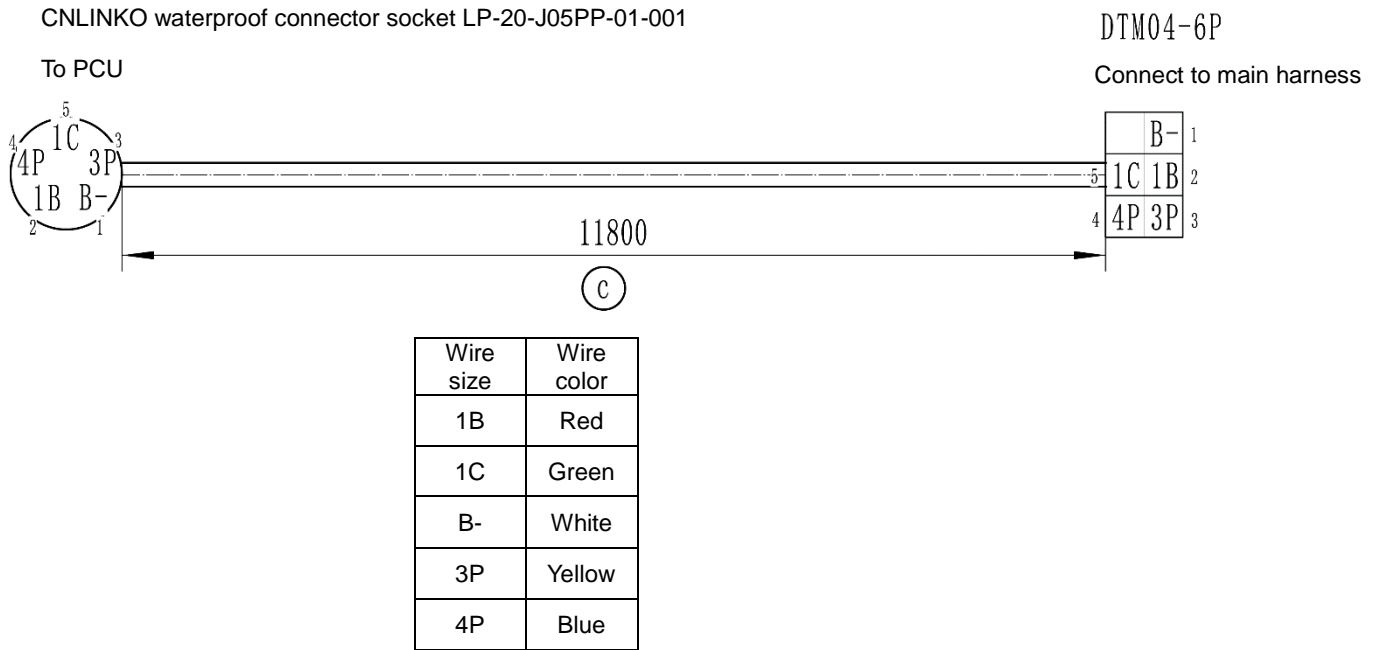

Fork harness connection diagram:

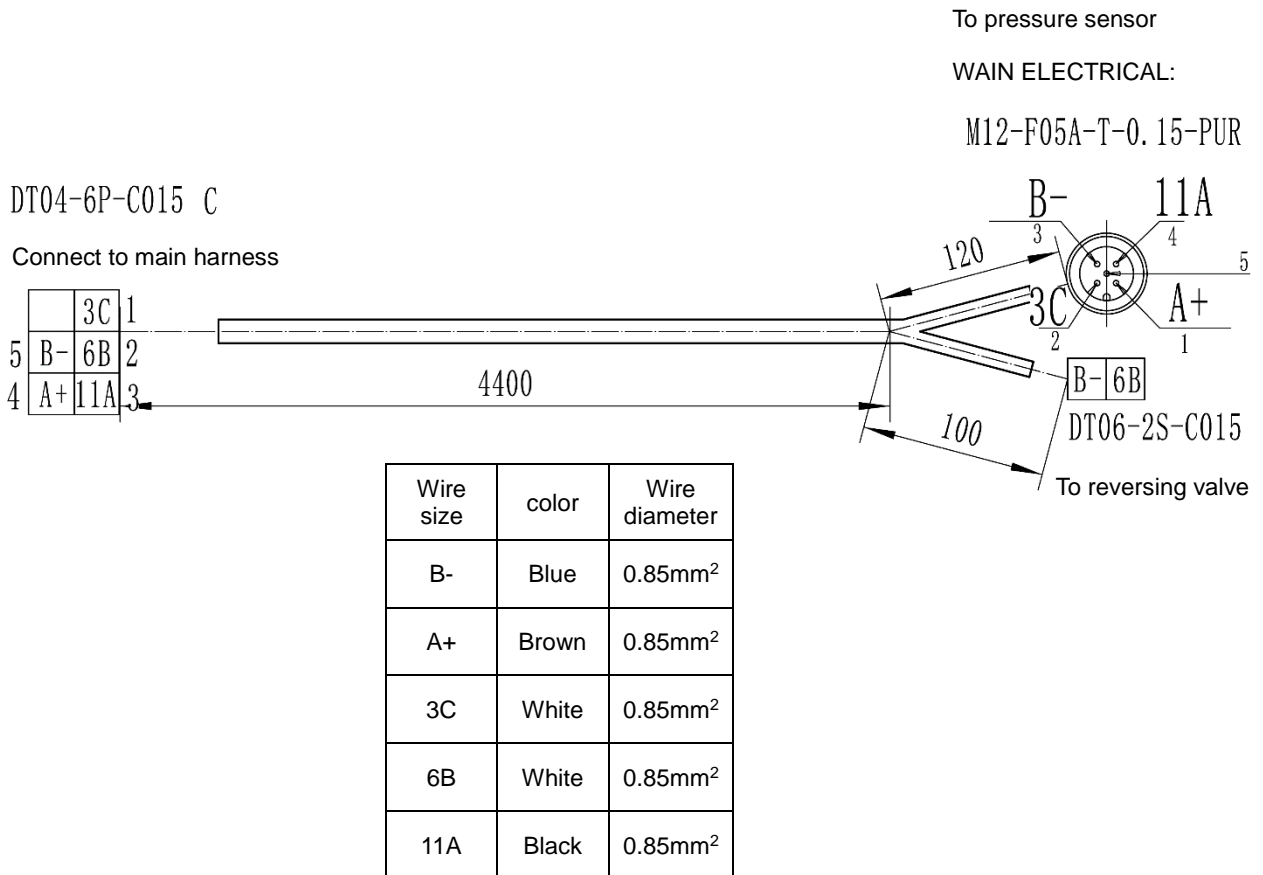

7.5.10 S3246 II , S3246E II PCU harness and fork harness

PCU harness connection diagram:

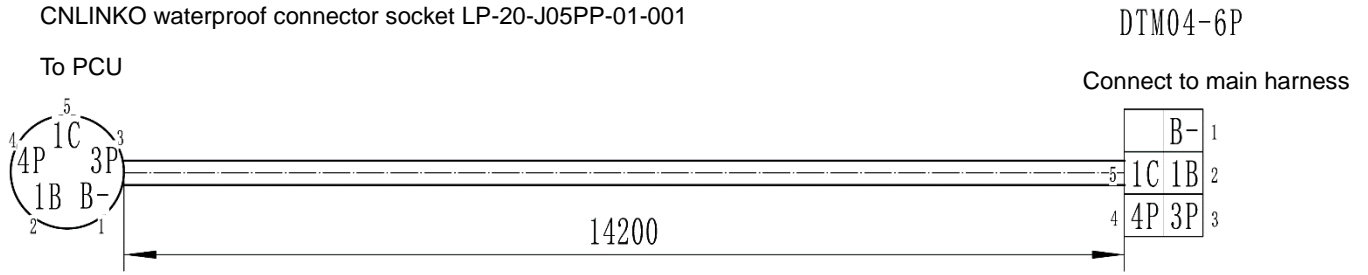

Wire size	Wire color
1B	Red
1C	Green
B-	White
3P	Yellow
4P	Blue

Fork harness connection diagram:

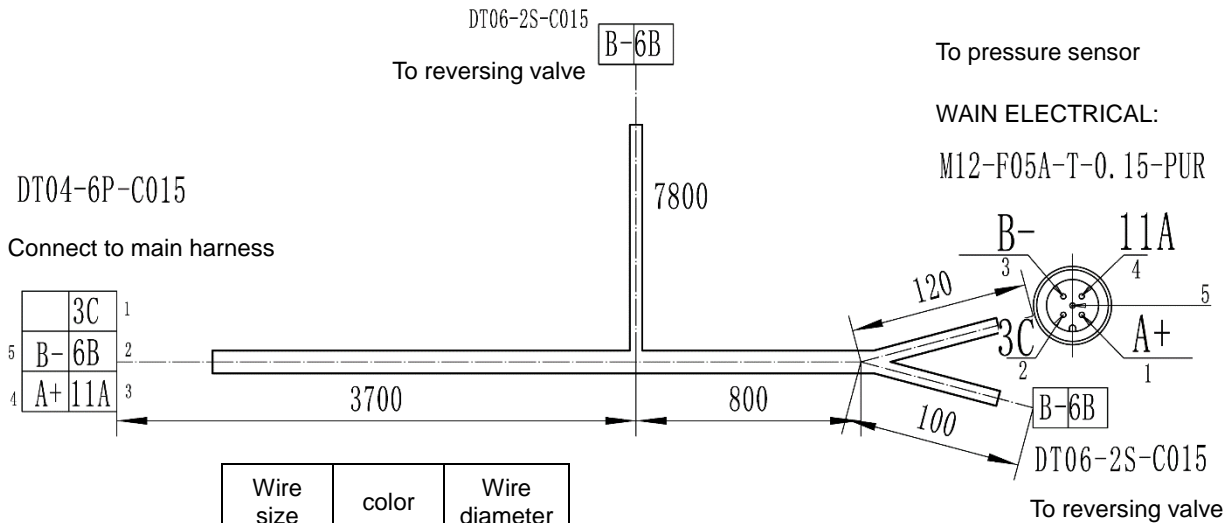

Wire size	color	Wire diameter
B-	Blue	0.85mm <sup>2</sup>
A+	Brown	0.85mm <sup>2</sup>
3C	White	0.85mm <sup>2</sup>
6B	White	0.85mm <sup>2</sup>
11A	Black	0.85mm <sup>2</sup>

7.5.11S4046 II and S4046E II PCU harness and fork harness

PCU harness connection diagram:

CNLINKO waterproof connector socket LP-20-J05PP-01-001

DTM04-6P

To PCU

Connect to main harness

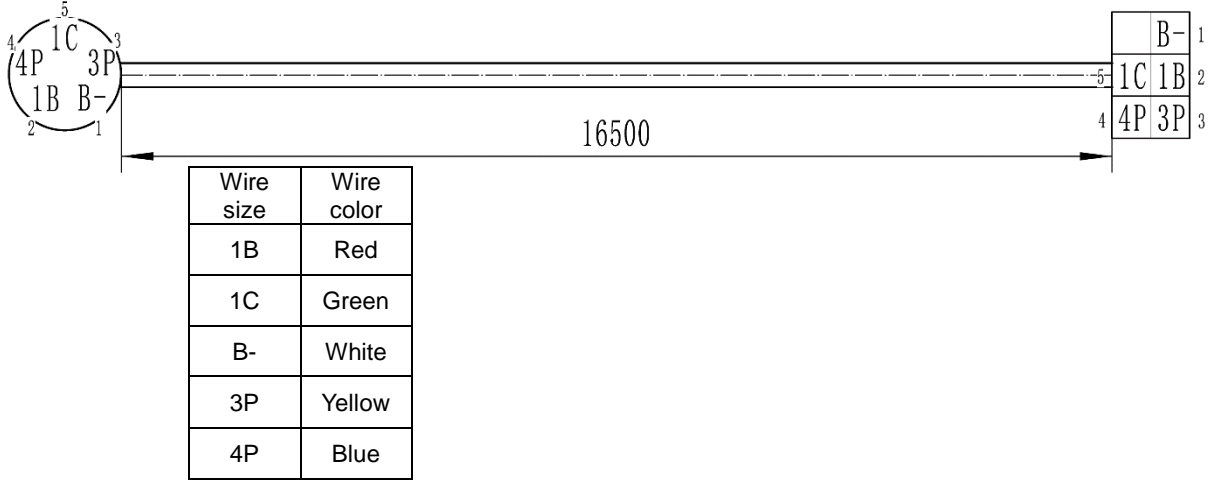

Fork harness connection diagram:

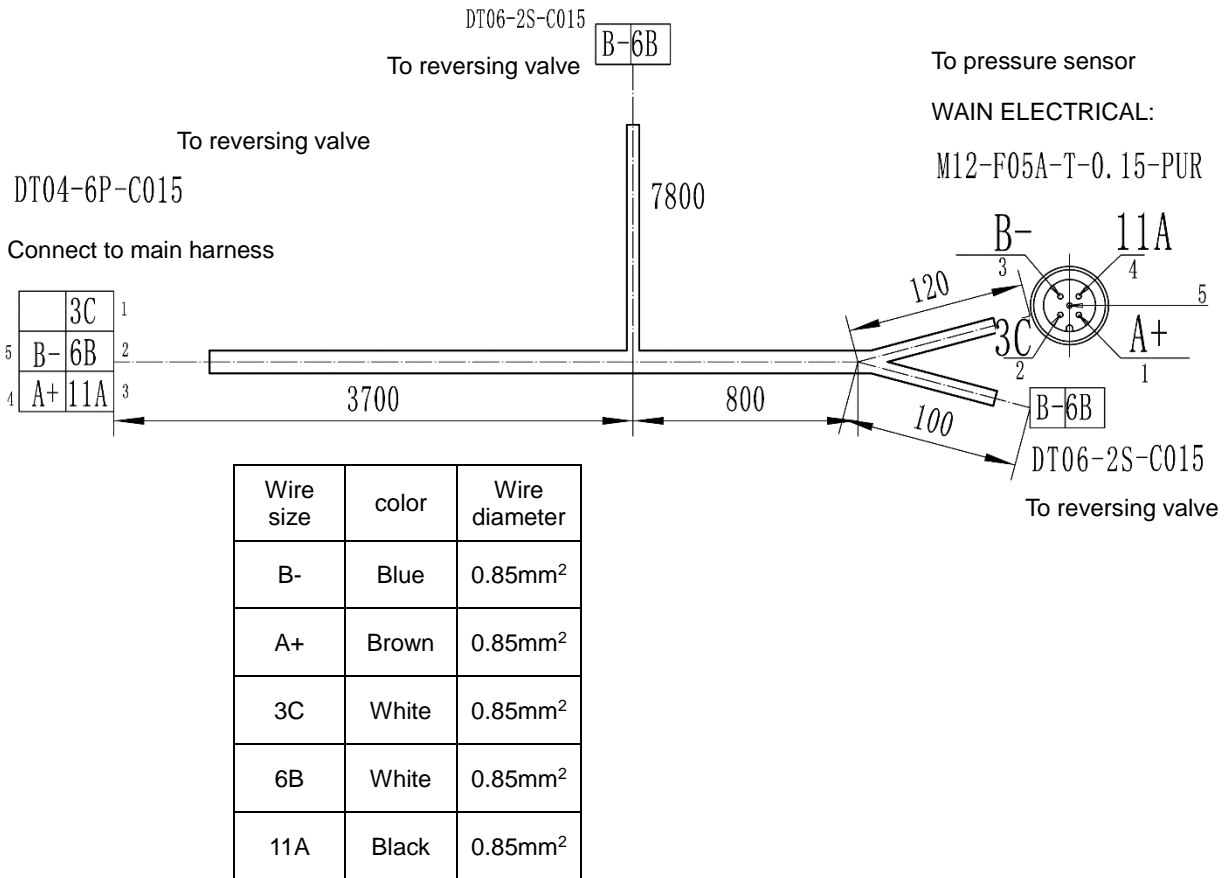

7.5.12S4650 II and S4650E II PCU harness and fork harness

PCU harness connection diagram:

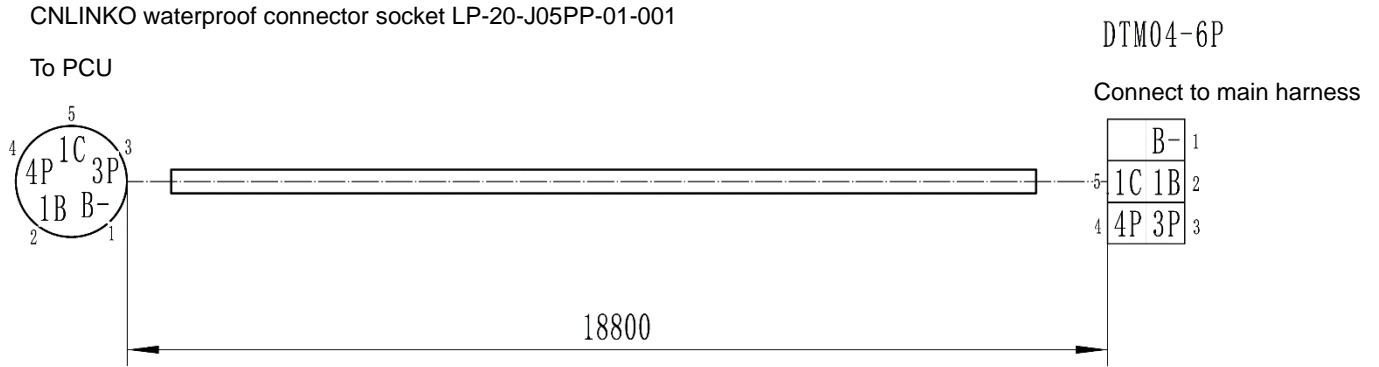

Wire size	Wire color
1B	Red
1C	Green
B-	White
3P	Yellow
4P	Blue

Fork harness connection diagram:

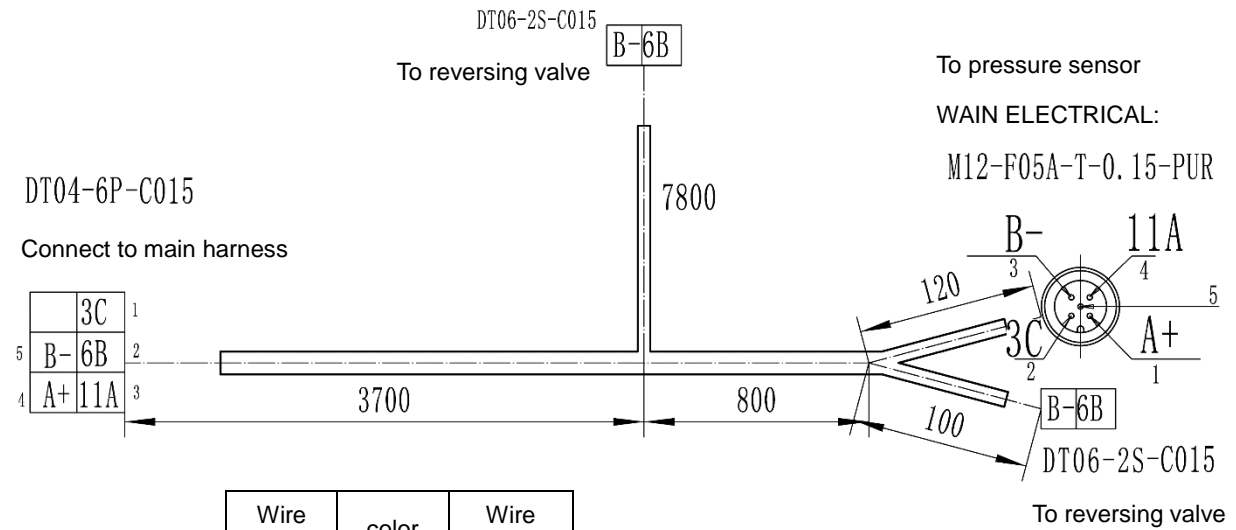

Wire size	color	Wire diameter
B-	Blue	0.85mm <sup>2</sup>
A+	Brown	0.85mm <sup>2</sup>
3C	White	0.85mm <sup>2</sup>
6B	White	0.85mm <sup>2</sup>
11A	Black	0.85mm <sup>2</sup>

### 7.5.13 Troubleshooting of Electrical Wiring

The electrical wiring in good condition is critical to the safe operation and performance of the machine. Failure to identify and replace burnt, worn, corroded or squeezed wires may result in unsafe operating conditions and damage to machine components. When the machine fails, the visual inspection of common electrical circuits mainly includes the following aspects:

1. Fixing condition: all electrical components and wires shall be fixed reliably. The outer shell shall be intact, and the components and parts shall be intact.
2. Contact and cleaning conditions: check whether the connectors are plugged tightly, whether there is corrosion, oil stain and ablation at the contact point, and the surface of the wire shall be free of oil stains, dirt and dust.
3. Insulation and shielding conditions: the insulation layer of the wire shall be free from damage and aging, the exposed area of the wire shall be covered with adhesive tape, and the shielding layer of the wire shall be free from fracture and scratch.
4. Fuse and relay conditions: each fuse and relay shall be installed firmly, the wire connection shall be in good contact, and the selected fuse and relay shall be complete and meet the rated value requirements of the circuit.
5. Operating conditions of each switch: each switch and button shall operate easily without jamming or failure.

Troubleshooting steps for electrical wiring:

1. Inspect for damaged or missing ground busbars on the underside of the chassis.
2. Check the following areas for burnt, worn, corroded or loose wires:
  - 1) Interior of GCU box

- 2) Hydraulic valve block wire
- 3) Wire in battery area wire in battery tray
- 4) Fork wire
- 5) The interior of PCU box
3. Turn the key switch to the chassis controller position and then pull out the red "Emergency shutdown" button on the PCU to the "ON" position.
4. Raise the platform to approximately 2.4 m/7.87 ft above the ground.
5. Turn the protective arm away from the machine to make it sink.
6. Lower the platform to the protective arm position.



**CAUTION:** danger of crushing. Make sure that your hands do not touch the protective arm as the platform is descending.

7. Check the center chassis area and the fork for burnt, worn and squeezed wires.
8. Check for burnt, worn, corroded, squeezed or loose wires in the following areas:
  - 1) Fork
  - 2) Electrical control unit to PCU
  - 3) Power to PCU wire
9. Check the free coating of insulating oil at the following locations:
  - 1) Harness connector between ECU and PCU
  - 2) All harness connectors connected to the horizon sensor
10. Raise the platform and return the protective arm to the stowed position.
11. Lower the platform to the stowed position and shut down the machine.

## 7.6 Error code (alarm code)

 CAUTION: In false alarm state, the alarm code will flash once per second on the display on the ECU and PCU.

### 7.6.1 Alarm code table

Display	Description	Machine reaction	Troubleshooting guidance
01	System initialization error	Stop all actions	Restart equipment or replace ECU
02	System communication error	Stop all actions	Check the connection between communication lines and other cables. If the fault still cannot be eliminated, please replace the PCU or ECU.
03	Machine type error	Stop all actions	Enter the parameter adjustment menu and modify the machine parameters.
05	Connection interruption of BMS	No lifting, no walking	Check whether the CAN bus is in poor contact or replace the lithium battery
09	Pedal failure alarm	No lifting, no walking	Release the foot switch. If it is invalid, check the connection status of the pedal harness (for short circuit, etc.)
10	Height limit lever triggered	No lifting, no walking	The alarm can be cancelled by lowering
11	Upper and lower limits are abnormal	No limit	Recalibrate the upper limit or the outdoor limit
12	(Chassis lift button) pressed incorrectly	Stop all chassis controls	Check whether the chassis lift or lower button is pressed at power-up, or replace the ECU
14	MCU 1 communication failure	No lifting, no walking	Check CAN bus for poor contact or modify electric drive type
15	MCU 2 communication failure	No lifting, no walking	Check CAN bus for poor contact or modify electric drive type
16	BMS failure	No lifting, no walking	Check whether the CAN bus is in poor contact or replace the lithium battery
18	Pothole protection error	No lifting, no walking	Pothole protection error: check whether the pothole protection is enabled and check the pothole protection limit switch. Check the lower limit switch and wiring.
23	Lifting limit triggered	No traveling	This reminder can be canceled in case of drop
27	Lowering proportional valve failure	No lifting, no walking	Check or replace the lowering proportional valve
31	Pressure sensor failure	No lifting, no walking	Check the sensor wiring and the sensor itself, and check whether the sensor is not installed but the weighing function is turned on.
32	Angle sensor failure	No lifting, no walking	Check the sensor wiring and the sensor itself, and check whether the sensor is not installed but the weighing function is turned on.
33	Light load not calibrated	No lifting	Calibrate the light load, or turn off the double load function.
34	Decline after overload	No reaction	This fault is only saved and not displayed. It is used to remind the operator.
35	Calibration of no load and full load	No reaction	Re-calibrate no load and full load
36	Low battery voltage	High-speed walking prohibited	If battery power is low, charge it in time; If the battery power is normal, check the wiring or replace the ECU.
38	Calibration error, and re-calibration required	No lifting	Conduct re-calibration
40	GPS communication failure	No reaction	Check CAN bus for poor contact or replace GPS equipment
41	Level 1 vehicle locking via GPS	No lifting	Unlock or connect GPS equipment
42	Handle left button pressed before starting	No reaction	Make sure nothing presses the key on the handle. If so, consider replacing the handle or PCU.
43	Handle right button pressed before starting	No reaction	Make sure nothing presses the key on the handle. If so, consider replacing the handle or PCU.
44	ZAPI 1 fault (Parameter setting failure of AC pump motor)	No reaction	Replace the motor drive or contact the motor drive manufacturer



Display	Description	Machine reaction	Troubleshooting guidance
45	ZAPI 2 fault (AC pump motor hardware fault)	No reaction	Replace the motor drive or contact the motor drive manufacturer
46	Handle enable button pressed before starting	Disable PCU action	Make sure nothing presses the key on the handle. If so, consider replacing the handle or PCU.
47	Handle not in the neutral position before starting	No reaction	Confirm that the handle is in the neutral position, check the neutral position parameter, and if there is no problem, try to replace the PCU or handle
49	AC pump motor: motor detection fault	No reaction	Replace the motor drive or contact the motor drive manufacturer
50	AC pump motor contactor fault	No reaction	Replace the motor drive or contact the motor drive manufacturer
51	Wireless anti-collision alarm	No lifting	The alarm can be cancelled in case of drop
52	Forward valve failure	No lifting, no walking	Check the connection of the coil and confirm that there is no problem. If there is no problem, check whether the coil itself is short circuited or open circuit.
53	Backward valve fault	No lifting, no walking	Check the connection of the coil and confirm that there is no problem. If there is no problem, check whether the coil itself is short circuited or open circuit.
54	Lifting valve fault	No lifting, no walking	Check the connection of the coil and confirm that there is no problem. If there is no problem, check whether the coil itself is short circuited or open circuit.
55	Lowering switch valve fault	No lifting, no walking	Check the connection of the coil and confirm that there is no problem. If there is no problem, check whether the coil itself is short circuited or open circuit.
56	Right turn valve fault	No lifting, no walking	Check the connection of the coil and confirm that there is no problem. If there is no problem, check whether the coil itself is short circuited or open circuit.
57	Left turn valve fault	No lifting, no walking	Check the connection of the coil and confirm that there is no problem. If there is no problem, check whether the coil itself is short circuited or open circuit.
58	Brake coil fault	No lifting, no walking	Check the connection of the coil and confirm that there is no problem. If there is no problem, check whether the coil itself is short-circuited or open-circuited.
60	MCU fault	No lifting, no walking	Replace the motor drive or contact the motor drive manufacturer
61	Fault of MCU current sensor	No reaction	Replace the motor drive or contact the motor drive manufacturer
62	MCU hardware damaged	No reaction	Replace the motor drive or contact the motor drive manufacturer
63	MCU output fault	No reaction	Replace the motor drive or contact the motor drive manufacturer
64	MCU SRO fault	No reaction	Replace the motor drive or contact the motor drive manufacturer
67	MCU HPD fault	No reaction	Replace the motor drive or contact the motor drive manufacturer
68	Low voltage	No lifting or high-speed walking	Do charging in time; If the battery power is normal, check the wiring or replace the ECU.
69	High-neutral current fault of MCU	No lifting, no walking	Replace the motor drive or contact the motor drive manufacturer
70	MCU steering input out of range	No lifting, no walking	Replace the motor drive or contact the motor drive manufacturer
71	MCU contactor fault	No lifting, no walking	Replace the motor drive or contact the motor drive manufacturer
73	MCU overheating	No reaction	Replace the motor drive or contact the motor drive manufacturer
74	MCU fault	No reaction	Replace the motor drive or contact the motor drive manufacturer
75	MCU pump motor fault	No lifting, no walking	Replace the motor drive or contact the motor drive manufacturer
76	MCU left drive motor fault	No lifting, no walking	Replace the motor drive or contact the motor drive manufacturer
77	MCU right drive motor fault	No lifting, no walking	Replace the motor drive or contact the motor drive manufacturer
78	MCU pump motor	No lifting, no walking	Replace the motor drive or contact the motor drive

Display	Description	Machine reaction	Troubleshooting guidance
	short circuit		manufacturer
79	Short circuit in left drive motor	No lifting, no walking	Replace the motor drive or contact the motor drive manufacturer
80	Warning for 80% weight	No reaction	If the platform load limit is approached, consider not increasing the load.
81	Short circuit in right drive motor	No lifting, no walking	Replace the motor drive or contact the motor drive manufacturer.
82	Left brake coil fault	No lifting, no walking	Check the connection of the coil and confirm that there is no problem. If there is no problem, check whether the coil is short-circuited or has an open circuit.
83	Right brake coil fault	No lifting, no walking	Check the connection of the coil and confirm that there is no problem. If there is no problem, check whether the coil is short-circuited or has an open circuit.
84	Motor POST Short Fault	No lifting, no walking	Replace the motor drive or contact the motor drive manufacturer.
89	Motor excitation open circuit fault	No lifting, no walking	Replace the motor drive or contact the motor drive manufacturer.
90	90% weight warning	No reaction	If the platform load limit is approached, consider not increasing the load.
91	Motor excitation short circuit error	No lifting, no walking	Replace the motor drive or contact the motor drive manufacturer.
92	Motor excitation short circuit error	No lifting, no walking	Replace the motor drive or contact the motor drive manufacturer.
93	AC pump fault, brake fault	No reaction	Replace the motor drive or contact the motor drive manufacturer.
94	AC pump fault, drive temperature fault	No reaction	Replace the motor drive or contact the motor drive manufacturer.
95	AC pump fault, motor temperature fault	No reaction	Replace the motor drive or contact the motor drive manufacturer.
96	AC pump fault, voltage or electric quantity abnormality	No reaction	Replace the motor drive or contact the motor drive manufacturer.
97	AC pump fault, CANBUS communication fault	No reaction	Replace the motor drive or contact the motor drive manufacturer.
98	AC pump fault, speed sensor fault	No reaction	Replace the motor drive or contact the motor drive manufacturer.
99	99% weight warning	No reaction	If the platform load limit is approached, consider not increasing the load.
100-114	Three-phase AC drive node 8 fault (display 100-114)	No reaction	Replace the motor drive or contact the motor drive manufacturer.
115-128	Three-phase AC drive node 9 fault (display 115-128)	No reaction	Replace the motor drive or contact the motor drive manufacturer.
129-142	Three-phase AC drive node A fault (display 129-142)	No reaction	Replace the motor drive or contact the motor drive manufacturer.
LL	Tilt exceeding safety limit	No lifting, no walking	If the machine tilts, try to restore it horizontal; if it is not tilted, check the horizon sensor wiring and the sensor itself and recalibrate the built-in inclination angle.
OL	Overload	No lifting, walking or lowing	Remove the heavy load immediately.

Historical error status:

1. The controller can display the last 10 error alarm codes. Press the right turn button at the top of the handle for 10 seconds (do not press and hold the handle enable button) to enter the historical error state.
2. Press the left turn button to browse past error codes until the earliest one; Press the right turn button to search for historical error codes in the opposite direction until the latest one. See the above table for the error code.

Press the enable switch on the handle to return to the normal operation state.

## 7.6.2 Operation flow diagram

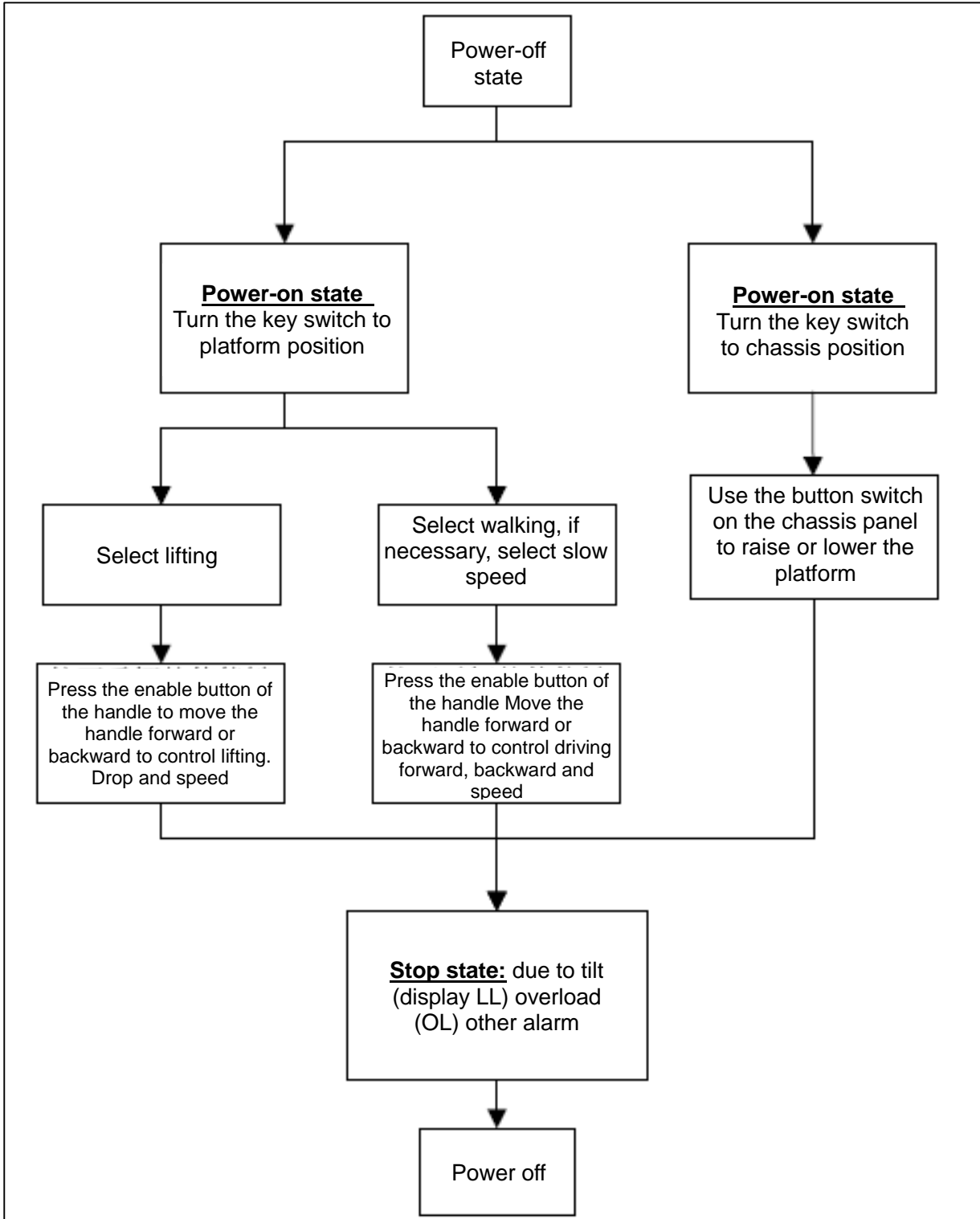

## Chapter 8 Maintenance of Complete Machine



 **WARNING:** Observing the regulations

- The operator can only perform the routine maintenance items specified in this manual.
- According to the requirements specified by the manufacturer, the regular maintenance inspection shall be completed by trained maintenance technicians

## 8.1 Checking the battery

The good condition of the battery is essential for performance and safe operation. Unsuitable electrolyte level or damaged cables and wiring may cause component damage and even dangerous conditions.

 **CAUTION:** For machines with sealed batteries or maintenance-free batteries, the electrolyte level may not be checked. Other positions shall be checked.

 **DANGER**

Danger of electric shock:

Live operation may result in serious physical injury or death. Remove all rings, watches and other jewelry before operation.

Danger of personal injury:

Battery electrolyte has corrosiveness. Prevent hands or other parts of the body from contacting with spilled electrolyte to avoid injury. Use baking soda to neutralize the spilled electrolyte.

 **CAUTION:** The following checks shall be

carried out with sufficient battery power:

- Wear protective clothing and protective glasses.
- Ensure that the wiring of the battery cable is firm and not corroded.

- Ensure that the battery lock lever is secure.
- Remove the battery ventilation cover.
- Check the battery electrolyte level. If necessary, add distilled water from the bottom of the battery filling pipe. Do not add it excessively.
- Install the ventilation cover.

 **CAUTION:** the addition of terminal protector

and anti-corrosion sealant will help to eliminate corrosion of battery terminal and cables.

## 8.2 Check the hydraulic oil

Check the hydraulic oil level

A proper hydraulic oil level is essential for the operation of the machine. If the hydraulic oil level is improper, the hydraulic components may be damaged. Through routine inspection, inspectors can determine changes in the hydraulic oil level, which can indicate problems in the hydraulic system.

 **CAUTION:** Perform this procedure with the platform retracted.

- a) Visually inspect the fluid level on the side of the hydraulic tank.

Result: the hydraulic oil level is at the mark of the tank.

- b) Add oil as needed and never add it excessively.

 **CAUTION:** During addition of the hydraulic

oil, it is needed to use the corresponding hydraulic oil according to the operating environment and temperature. Refer to the followings:

Minimum temperature	Model of hydraulic oil
Minimum temperature > -9°C	L-HM (high pressure) 46 anti-wear hydraulic oil

-33℃ < minimum temperature ≤ -9℃	L-HV #46 low temperature hydraulic oil
-39℃ < minimum temperature ≤ -33℃	L-HS #46 Ultra-low temperature hydraulic oil
Minimum temperature ≤ -39℃	No. 10 aviation hydraulic oil

Perform hydraulic oil analysis

1. This check is carried out every 25 hours or once a month, whichever comes first.
2. Changing or testing hydraulic oil is critical to the performance and service life of the equipment. Contaminated hydraulic oil may affect equipment performance, and its continuous use will cause equipment damage. It should be checked more frequently in a harsh working environment.
3. Before the hydraulic oil change, its necessity can be tested by the oil stain separator.
4. If the hydraulic oil has not been changed for two years, it shall be tested quarterly. If it fails the test, change the hydraulic oil.
5. Refer to Testing or changing hydraulic oil.

Testing or changing hydraulic oil

1. This procedure is checked every 200 hours or every year, whichever comes first.
2. Changing or testing hydraulic oil is essential for good machine performance and service life. Dirty hydraulic oil and suction filter will affect the machine performance, and their continuous use will cause damage to parts. This operation shall be carried out more frequently in harsh working environments.
3. Verify whether the changing is necessary with an oil stain separator before changing the hydraulic oil.
4. If the hydraulic oil has not been changed for two years, it shall be tested once every quarter. If the test fails, change the hydraulic oil:

 **CAUTION:** Disconnection of the battery pack on the machine shall be carried out when the machine is retracted.

 **WARNING:** operation in a live circuit may

result in serious injury or death. Remove rings, watches and other jewelry before operation.

- 1) Open the installation tray of the hydraulic power unit.
- 2) Mark and disconnect the return pipe from the hydraulic filter to the hydraulic tank and remove the pipeline from the tank. Cover the pipe fitting to prevent dust.
- 3) Mark and disconnect the suction pipes of the hydraulic pump and tank, and take out the pipes. Cover the pipe fitting to prevent dust.
- 4) Loosen the hydraulic tank fasteners and take out the hydraulic tank.
- 5) Unscrew the hydraulic oil filler cap and pour the oil into a suitable container.

 **WARNING:** the sprayed hydraulic oil can penetrate the skin. During loosening of the hydraulic fitting, the speed should be very low, so that the oil pressure can gradually decrease. Do not let the oil spray out.

- 6) Clean the spilled hydraulic oil and use the drained hydraulic oil correctly.
  - 7) Clean the hydraulic tank with a mild solvent and dry it thoroughly.
5. Refit the hydraulic tank and install the fasteners for tightening the hydraulic tank. Connect the hydraulic pump inlet pipe to the oil tank.
  6. Connect the hydraulic tank return pipe to the return filter.
  7. Fill the oil tank with hydraulic oil, be careful



not to spill, and tighten the filler cap.

8. Start the oil pump to fill the entire hydraulic system with hydraulic oil and discharge air from the hydraulic system.

 **WARNING:**

Operation without oil may cause damage to the hydraulic oil pump. When filling the hydraulic system with oil, be careful to empty the tank. Do not allow cavitation of the hydraulic pump.

### 8.3 check the wire

This item is checked every 25 hours or every month, whichever comes first.

Keeping the wires in good condition is essential for safe operation and good machine performance. Failure to find and replace the burned, scratched, corroded or bent wires will lead to an unsafe operating environment, causing damage to the machine parts.

 **DANGER:** electric shock/explosion hazard

Thermal contact or electrical conductors may lead to serious casualties. Do not wear rings, watches and other jewelry.

1. Check whether the ground wires under the chassis are missing or damaged.
2. Inspect for burned, scratched, corroded, bent or loose wires in the following areas:
  - Interior of GCU box
  - Hydraulic valve block wire
  - Wire in battery area wire in battery tray
  - The interior of PCU box
3. Turn the key switch to the PCU and pull out the red emergency stop button on the GCU and PCU.
4. Raise the platform to a certain height from the ground.
5. Move the safety arm to the middle of the scissor shaft sleeve and rotate it down to the

vertical state.

6. Lower the platform height until the safety arm is in full contact with the shaft sleeve.

 **DANGER:** risk of crushing

Make sure that the hand is in the correct position of the safety arm as the platform descends.

7. Examine the chassis and scissor areas for burns, scratches, corrosion, bending and loose wires.
8. Inspect for burnt, scratched, corroded, bent or loose wires in the following areas:
  - Scissor arm wire
  - ECU to platform
  - Harness connector connected to the platform
9. Check the free coating of insulating oil at the following locations:
  - Harness connector between ECU and PCU
  - All harness connectors connected to the horizon sensor
10. Raise the platform and restore the safety arm to the installation position.
11. After lowering the platform to the retraction position, shut down the machine.

### 8.4 check tire and hub

This check is carried out every 25 hours or once a month, whichever comes first.

Keeping the tire and hub in good condition is essential for safe operation and good performance. Failure of tires and hubs may cause the machine to tip over. If the failure isn't found or eliminated in time, the machine parts will be damaged.

1. Check the tire tread and sides for scratches, cracks, punctures and other abnormal wear.
2. Check the hub for damage, bending and cracking.
3. Remove the cotter pin and check the nut

torque.

**!** CAUTION: New cotter pins must be used when reinstalling.

4. Fit and lock the new cotter pin.

Nut torque without lubrication	410-540N·m
--------------------------------	------------

**!** CAUTION: Model suitable for electrical driven machine.

5. Check the torque of all the bolts

Torque of the bolt without lubrication	90N·m
--	-------

6. Lubricate the steering knuckle.

### 8.5 Checking ventilation system of the hydraulic tank cover.

1. This check is carried out every 25 hours or once a month, whichever comes first.
2. A hydraulic tank cover with unobstructed exhaust is essential to achieve good mechanical performance and service life of the machine. Dirty or clogged vent cap may lead to poor performance of the machine. It should be checked more frequently in a harsh working environment.

1) Remove the vent cap from the hydraulic tank cover.

2) Conduct ventilation installation.

Result: air can pass through the vent cap.

Result: If the air cannot pass through the vent cap, clean or replace the vent cap. Continue with step 3.

**!** CAUTION:

During inspection of the ventilation and exhaust of the tank cap, the air shall be able to pass freely.

3. Clean the tank vent cap carefully with a mild solvent and dry it with low pressure compressed air. Repeat Step 2.

4. Install the hydraulic tank vent cap.

### 8.6 Inspect the chassis tray lock

1. This inspection shall be carried out every 25 hours or once a month, whichever comes first.
2. Keeping the chassis tray lock in good condition is crucial to the performance and service life of the equipment. Damaged chassis tray lock may cause the tray to be opened accidentally, causing potential safety hazards. Check each chassis tray lock for wear and damage.

### 8.7 Inspection of Steering Knuckle

1. This inspection shall be conducted every 25 hours or every month, whichever comes first.
2. The quality of the steering knuckle copper washer is crucial to the safe operation of the machine. The use of worn copper washer may lead to component damage and work hazards.
3. Check while the platform is retracted.
4. Measure the distance between the chassis bushing and the upper cover plate of steering knuckle, as shown in the following figure. (No steering knuckle copper washer)

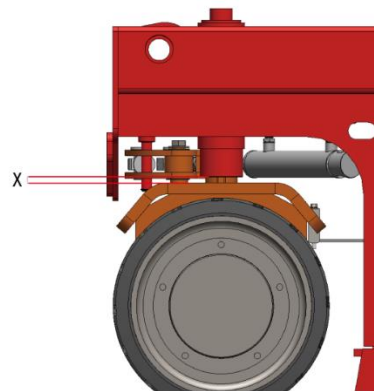

Result:

- a) If the measurement result is less than or equal to 9 mm/0.35in, replace the nylon gasket inside the steering knuckle.
- b) If the measurement result is more than 9 mm/0.35 in, there is no need to replace the nylon gasket inside the steering knuckle.

## 8.8 Replace the hydraulic tank vent cap

1. Perform this step every 50 hours or quarter, whichever comes first.
2. The hydraulic oil tank is a vented tank. There is an air cleaner inside the vent cap, which may become blocked over time. In case of vent cap failure or improper installation, once impurities enter the hydraulic system, component damage may occur. The vent cap should be checked frequently especially in harsh working environment.

- 1) Take out the hydraulic tank vent cap.
- 2) Renew the hydraulic tank vent cap.

## 8.9 Checking wear-resistant slider of scissor arm

1. Perform this step every 100 hours or 6 months, whichever comes first.

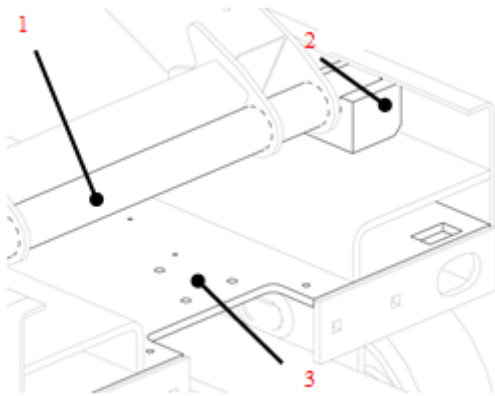

1. Inner link tube 2. Wear block 3. Bottom plate
2. The quality of the scissor arm wear-resistant block is crucial to the safe operation of the machine. The use of worn wear-resistant slider may cause damage to components and unsafe work risks.
3. Check the wear washer when the platform is retracted.

- 1) Measure the distance from the inner link tube on the battery box side of the non-steering end to the floor plane.

Result 1: The measurement result is greater than or equal to 24 mm/0.94 in. Perform step 2);

Result 2: The measurement result is less than 24 mm. Replace the wear-resistant slider.

2) Measure the distance from the fork inner link tube at the battery side on the non-steering end of the machine to the plane of the floor slide.

Result 1: The measurement result is greater than or equal to 24 mm/0.94 in. Perform step 3);

Result 2: The measurement result is less than 24 mm/0.94 in. Replace the wear-resistant slider.

3) Apply lubricant between the chassis slide and the wear-resistant slider.

## 8.10 Inspection and replacement of brushes



**WARNING:** it is forbidden to carry out inspection and maintenance when the power is on.

### 1. Regular inspection

Check the motor at least once every 100 hours or half a year according to the following methods, whichever comes first.

- 1) External inspection to keep the outer surface of the motor clean.
- 2) Open the protective cover and clean up the carbon deposit.
- 3) Check or replace the bearing, and listen carefully to the bearing for abnormal noise during operation.
- 4) Check the brush wear and replace the brush as appropriate.

### 2. Fault analysis and troubleshooting

Fault phenomenon	Cause	Troubleshooting method
Blackening of commutator, excessive wear of		

Blackening of commutator, excessive wear of

brush or large spark Overload Reduce load and operation frequency

The pressure is reduced due to the struck brush or spring annealing. Clean up the carbon deposition, check the cause and replace the spring.

Brush inappropriate Replace it with a new one of the same brand and size as that of the original brush of the motor.

Serious carbon deposition in the motor Clean up carbon deposits.

### 3. Replace the brush

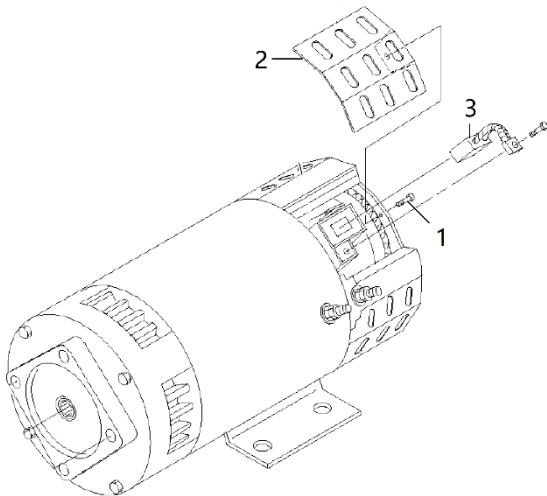

1. Bolt 2. Window cover plate 3. Brush

#### 1. Remove the window cover plate:

a) Unscrew the cover plate screw with a T-shaped wrench and remove the cover plate.

#### 2. Remove the old brush.

a) Unscrew the fastening screw of electric brush tail with Phillips screwdriver or socket wrench.

B) Pull up the spring, take out the old brush from the brush box, and clean the carbon powder accumulated on the surface of the brush box and brush.

#### 3. Install a new brush

a) Put the new brush into the brush box and press the brush with a spring.

b) Fix the brush tail on the terminal block of the brush box with a Phillips screwdriver or a T-wrench, and tighten it with a torque wrench.

#### 4. Install window cover plate

a) Insert the cover plate into the window buckle, tighten the fastening screws (with flat washers and spring washers), and tighten them with torque wrench.

**!** CAUTION: after the new brush is installed, let the motor idle, carry out running-in of the arc surface of the brush, and increase the contact surface between the brush and the commutator.

**!** CAUTION: do not use the motor in case of over-load or under-voltage, otherwise it may cause large current and accelerate brush wear.

## 8.11 Replacing hydraulic tank return filter element

Note: this step shall be performed every 100 hours or 6 months, whichever comes first.

**!** CAUTION:

Replacement of the return filter element is essential for the good performance and service life of the machine. Dirty or clogged filters may affect the machine performance, and their continuous use will cause damage to parts. The filter element should be replaced more frequently in harsh working environment.

**!** WARNING: scalding hazard

Beware of hot oil. Exposure to hot oil may result in severe burns.

**!** CAUTION: The return filter of the hydraulic

tank is installed in the middle area between the function valve block and the hydraulic power unit.

1. Clean the hydraulic oil spilled around the filter and remove the filter with a wrench.

2. Disassemble the filter and renew the filter element.

3. Apply a layer of hydraulic oil to the filter sealing

ring and tighten it with a wrench.

4. Use the marker pen to note the replacement time and date on the filter element replacement sheet.
5. Turn the key switch to the ground control, and pull out the red emergency stop button on the GCU and PCU.
6. Press and pull down the lift function selection button.
7. Check the filter components for oil leakage.
8. Clean the hydraulic oil spilled around.

## 8.12 Maintenance Items

Routine inspection and maintenance interval table:

Maintenance level	Routine inspection	Level 1 maintenance	Level 2 maintenance	Level 3 maintenance	Level 4 maintenance	Level 5 maintenance
Maintenance period	Every day	25h/1m	50h/3m	100h/6m	200h/12m	400h/24m



**CAUTION:** the working hours are subject to the hour meter.

See the following table for maintenance items of all levels:

Maintenance items	Operation content	Maintenance level					
		Routine inspection	Level 1 Maintenance	Level 2 Maintenance	Level 3 maintenance	Level 4 maintenance	Level 5 maintenance
Electrical system	Check battery capacity	•	•	•	•	•	•
	Check whether the buttons of the PCU panel operate normally.	•	•	•	•	•	•
	Check whether the PCU emergency stop switch is secure	•	•	•	•	•	•
	Check whether the switch operation is sensitive	•	•	•	•	•	•
	Is the spring harness damaged	•	•	•	•	•	•
	Check whether the PCU harness connector is secure	•	•	•	•	•	•
	Check whether the PCU harness connector is defaced	•	•	•	•	•	•
	Check whether the PCU harness is extruded or broken	•	•	•	•	•	•
	Is the pressure switch wiring firm	•	•	•	•	•	•
	Is the lowering solenoid valve firm	•	•	•	•	•	•
	Check	•	•	•	•	•	•

	whether the horizon sensor and inclination sensor are wired firmly						
	Check if limit switch rocker arms are wired loosely	•	•	•	•	•	•
	Check whether the angle sensor harness and connector are secure	•	•	•	•	•	•
	Check whether the emergency stop switch, key switch, plug switch and wiring of ground control panel are loose	•	•	•	•	•	•
	Check whether the warning light and horn function is normal	•	•	•	•	•	•
	Check whether the wiring of motor, motor controller, relay and ECU is loose	•	•	•	•	•	•
	Check whether the solenoid valve coil wiring of the main valve block is normal or loose	•	•	•	•	•	•
	Check whether the charger wiring is loose or has corrosion	•	•	•	•	•	•
	Check whether the battery terminals are loose or rusted	•	•	•	•	•	•
	Check the battery	•					
	Overall performance and various limit switches	•					

	Check whether the connection of each connector is loose, interfered, or has corrosion	•	•	•	•	•	•	
Hydraulic system	Monitor whether the system pressure is normal	•	•	•	•	•	•	
	Check whether the lift pressure system is normal	•	•	•	•	•	•	
	Check whether the steering system pressure is normal	•	•	•	•	•	•	
	Check whether the running system pressure is normal	•	•	•	•	•	•	
	Check whether any oil pipes and joints are loose	•	•	•	•	•	•	
	Check the oil cylinder for oil leakage	•	•	•	•	•	•	
	Check each spool for oil leakage	•	•	•	•	•	•	
	Check whether the fork oil pipe is fixed firmly	•	•	•	•	•	•	
	Check whether the walking oil pipe fixing clip is loose	•	•	•	•	•	•	
	Check the oil level in the hydraulic tank	•	•	•	•	•	•	
	Change hydraulic oil	Replace it once a year						
	Hydraulic oil return filter element	Replace it every six months						
	Check the hydraulic tank vent cap for leaks	•	•	•	•	•	•	
	Replace the hydraulic tank vent cap			•	•	•		
	Change the	First 50 h, thereafter every 200 h						



	reducer lubricating oil							
Whole machine	Check the scissor slider for abnormal sound					•	•	
	Replace and inspect the slider					•	•	
	Check whether the bolts of the whole machine are loose and make abnormal noise	•						
	Check whether the circlip and gasket of the scissor arm are invalid	•						
	Check whether the emergency lowering device is normal	•						
	Check the platform, fork and chassis for deformation and open weld	•						
	Check whether the paint of the complete vehicle falls off	•						
	Check whether the safety identification is true or stained	•						
	Check whether the manuals and labels are missing, blurred or damaged	•						
	Overall performance and various limit switches	•						
	Overall performance and various limit switches	•						
	Steering knuckle	Lubricate once a month						

	lubrication	
--	-------------	--

## Chapter 9 Debugging of the Whole Machine



## 9.1 Basic function check



Fig. 9.1 PCU

- a. Left turn control switch
- b. Control handle
- c. Digital tube
- d. Horn button
- e. Single-way safety emergency stop switch
- f. Right turning control switch
- g. Low speed selection button
- h. Lifting selection button
- i. Walking selection button
- j. Indoor selection button
- k. Outdoor selection button
- l. Enable button

1. Check whether the remaining problems affect the debugging;
2. Check the whole machine for missing parts and missing installation;
3. Check the whole machine for oil leakage;
4. Preliminary test of fork lifting and lowering:

- 1) When the fork up button is pressed in situ, the lifting is normal;
- 2) When the fork down button is pressed in situ, the lowering is normal;

### 5. Preliminary test of driving forward and backward:

- 1) When the forward button is pressed, the driving forward is normal;
- 2) When the reverse button is pressed, the reversing is normal;

### 6. Steering preliminary test:

- 1) When the left turning button is pressed, the left turning is normal;
- 2) When the right turning button is pressed, the right turning is normal;

Note: during the preliminary test of the whole machine operation, turn the key to the PCU position, check for and record problems.

## 9.2 Hidden danger point inspection

### 1. Fork hidden danger point inspection:



Fig. 9.2 Fork hidden danger points

- 1) Check the fastening condition of pin fixing bolts of each fork;
- 2) Check the fixing condition of the circlip of each fork;
- 3) Check the fastening condition of the fixing bolt of the lift cylinder pin;
- 4) Check the fastening condition of fixing bolts of the front mounting plates of the bottom layer and the top layer;
- 5) Check the fixing bolt of the fork safety

support or the fastening of the circlip;

2. The hidden danger inspection of the chassis:



Fig. 9.3 Hidden danger points of chassis

- 1) Check the fastening of fixing bolts of the door lock and lock seat on the battery side and the fuel tank side;
  - 2) Check the fastening of fixing bolts of walking motor, brake disc and tire
  - 3) Check the fastening of steering knuckle limit bolt;
  - 4) Check the fastening of fixing bolts of the front and rear counterweights and baffle;
  - 5) Check the fastening of fixing bolt of the cushion block under the side door; Check the fastening of the cable handle;
3. Check the hidden danger spots of the platform:



Fig. 9.4 Hidden danger spots of the problem

- 1) Check the fastening of the guardrail fixing bolts of the main platform and the extended platform;
- 2) Check the fastening of the platform lifting fixing bolt.

- 3) Check the fastening of platform pedal bolts and wheel frame fixing bolts;
- 4) Check the fastening of the tie rod fixing bolts.

4. Check the safety support installation:

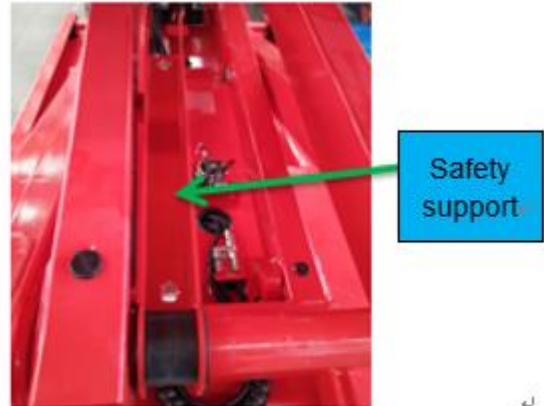

Fig. 9.5 Safety support

- 1) Fastened firmly without looseness;
- 2) Without defects of deformation or cracking;

Without jamming during the use.

### 9.3 Testing key switch

1. This check is carried out every 25 hours or once a month, whichever comes first.
2. Correct key switch actions and corresponding actions are essential for safe operation of the equipment. The machine can be operated by the GCU or the PCU by turning the key switch. Failed switch may cause dangerous operation.
3. The PCU shall be used on the ground when such steps are performed, so people shall not stand in the platform.
  - 1) Pull out the red emergency stop buttons on the GCU and PCU.
  - 2) Turn the key switch to the platform control.
  - 3) Check the lifting and lowering functions of the GCU.

Result: no action is performed on the machine.

- 4) Turn key switch to ground control.
- 5) Check the lifting and lowering functions in the PCU.

Result: the machine has no action

- 6) Turn the key switch to the off position.

Result: no action is performed on the machine.

### 9.4 Horn Test

This check is carried out every 25 hours or once a month, whichever comes first.

1. A horn is used by controlling person to send the sound on the platform for warning persons on the ground. A horn with abnormal function cannot remind persons on the ground of dangerous or unsafe conditions:

- 1) Turn the key switch to the platform control and pull out the red emergency stop button on the GCU and the PCU;
- 2) Press the horn button in the horn controller.

Result: the horn sounds.

### 9.5 Test Inclination switch



Figure 9.6 Inclination switch

Correct the inclination sensor at the horizontal platform:

1. For the switch with bubble inclination, first adjust the bubble in the center position, and then set the sensor to zero.
2. Inclination switch without bubble is used to zero the sensor.
3. Apply identification glue on sensor bolt

### 9.6 Testing emergency stop function



Fig. 9.7 Emergency stop switches of PCU and GCU

1. This check is carried out every 25 hours or once a month, whichever comes first.
2. Normal emergency stop function is essential for safe operation of the machine. Abnormal red emergency stop button will not be able to cut off the power supply and stop all functions of the machine, resulting in dangerous situations.
3. As a safety function, in addition to the red emergency stop button function on the platform, the selection and operation of the GCU takes precedence over those of PCU:

- 1) Turn the key switch to the ground control and pull out the red emergency stop buttons on the GCU and the PCU.
- 2) Press the red emergency stop button of the GCU to the off position.

Result: no action is performed on the machine.

4. Press the red emergency stop button of the PCU to the off position.

Result: no action is performed on the machine.



CAUTION:

All operations of the machine can be stopped through the red emergency stop button on the GCU even if the key switch is turned to the PCU.

## 9.7 Testing drive speed

1. This check is carried out every 25 hours or once a month, whichever comes first.
2. Normal drive functions are essential for operation safety. The drive function shall respond to the operator quickly and smoothly. Delay, bumps and abnormal noises shall not occur during normal operation and driving.
3. The drive test must be performed on a solid, flat, and barrier-free ground:
  - 1) Draw two lines 10 meters/ 32.8 feet apart on the ground as the starting line and finishing line.
  - 2) Turn the key switch to the platform control and pull out the red emergency stop buttons on the PCU and GCU.
  - 3) Lower the platform to the retraction position.
  - 4) Press the drive function selection button.
  - 5) Select a point on the machine as a reference visual inspection of crossing the starting line and finishing line.
  - 6) Drive the machine at the maximum speed and start timing when the reference point crosses the starting line.
  - 7) Keep driving at full speed and record the time of crossing the finishing line.

Check whether the standard is met.

## 9.8 Testing the function of drive brake

1. This check is carried out every 25 hours or once a month, whichever comes first.
2. Correct brake actions are essential for operation safety. The brakes are required to be smooth, without delay, bumps or abnormal noises. The hydraulic release

brake system shall also function properly.

3. To complete the brake function test, the machine must be carried out on a solid, flat and obstacle-free ground to ensure that the machine is in a retracted state and the extended platform is fully retracted.
  - 1) Draw a reference test line on the ground.
  - 2) Turn the key switch to the platform control and pull out the red emergency stop buttons on the GCU and PCU.
  - 3) Lower the platform to the retraction position.
  - 4) Press the drive function selector button.
  - 5) Select a point on the machine (e.g. touch point on the wheel) as a mark for visual inspection of crossing the reference test line.
  - 6) Drive the machine to the highest speed and release the handle at the moment the reference point crosses the ground test line.
  - 7) Measure the distance between the reference point and the surveying and mapping line.

Result: the machine stops within the specified braking distance. No action is required.

Result: the machine does not stop within the specified braking distance.

### CAUTION:

- The brake must be effective within the allowable gradeability of the machine;
- Replace the brake and repeat the above process from step 1.

## 9.9 Testing limit switch and pothole protection switch

This check is carried out every 25 hours or



once a month, whichever comes first.

Good limit switch is crucial to the performance and safe operation of the machine. Operating a machine with a defective limit switch will reduce the machine performance and lead to a potentially unsafe working environments.

To complete this inspection, the machine must be on a solid, flat and obstacle-free ground.

Lower limit switch

1. Remove the PCU.
2. Lift the platform to a certain height above the ground. The lifting height of each model is shown in the following table:

Lifting height of each model:

Model	Height (m/ft)
S1932 II/S1932E II	2.5/8.2
S2632 II/S2632E II	2.7/8.86
S2646 II/S2646E II	3.2/10.5
S3246 II/S3246E II	3.2/10.5
S4046 II/S4046E II	4/13.12
S4650 II/S4650E II	4/13.12

3. Move the safety arm to the middle of the scissor shaft sleeve and rotate it down to the vertical state.
4. Lower the platform until the safety arm is in full contact with the shaft sleeve.
5. Turn the key switch to the off position.
6. Take the handle off for testing.
7. Open the lower limit switch base cover and unplug the connector of the lower limit switch.
8. Turn the key switch to the platform control.
9. Slightly lift the platform and restore the safety arm.
10. Control the machine on the ground via the GCU and press the lifting function selection button to lower the platform to the retracted state.

Result: the diagnostic display will display code 11, the alarm sounds, and the

lifting function responds normally. The machine functions normally.

Result: the diagnostic display does not display the code 11, no alarm sounds, no response is available from the lifting function, and the limit switch needs to be replaced.

11. Press the drive function selection button and try to drive the machine.

Result: the diagnostic display will display code 11, the alarm sounds, and the steering and drive functions cannot be operated. The machine functions normally.

Result: the diagnostic display does not display the code 11, no alarm sounds, steering and drive functions can be performed, and the limit switch needs to be replaced.

12. Press the lifting function selection button to lift the platform about 0.3 m/0.98 ft.

Result: the diagnostic display will display code 11, the alarm sounds, and the lifting function can be operated. The machine functions normally.

Result: the diagnostic display does not display the code 11, no alarm sounds, and the limit switch needs to be replaced.

13. Lift the platform until the pothole protection device extends.

Result: the diagnostic display does not display code 11 and no alarm sounds. The machine functions normally.

Result: the diagnostic display will display code 11 and the alarm will sound. The limit switch shall be replaced.

14. Lift the platform to a certain height above the ground. For the lifting height of each model, see "lifting height of each model" in the table

above.

15. Lift the safety arm, move the safety arm to the middle of the scissor shaft sleeve, and rotate it down to the vertical state.
16. Lower the platform height until the safety arm is in full contact with the shaft sleeve.
17. Turn the key switch to the off position.
18. Disconnect the platform control line of the chassis main harness.
19. Restore the connection between the platform control connector and the chassis main harness.
20. Connect the platform control connector.
21. Connect the connector of the lower limit switch in a secure and correct manner.
22. Install the lower limit switch box.
23. Turn the key switch to the platform control.
24. Slightly lift the platform and restore the safety arm.
25. Lower the platform to retracted state

Inclination switch:

1. Move the machine to the maximum inclination angle allowed by the super-horizon sensor. See nameplate for the maximum allowable inclination angle.
2. Press the lifting function selection button to lift the machine to a certain height on the inclined ground

Result: the diagnostic display shows the code LL, the alarm sounds, and the machine functions normally.

Result: diagnostic display does not display code LL, and the alarm sounds, in this case, check or replace the inclination switch.

3. Press the drive function selection button and try to drive the machine on the slope.

Result: code LL is displayed on the diagnostic display, the alarm sounds, and the steering and drive functions are not available. The machine functions normally.

Result: the diagnostic display does not display the code LL, no alarm sounds, and the drive and steering functions are normal. Check or replace the inclination switch.

Pothole protection switch

1. Lower the platform to retracted state, and move the machine to the solid and flat ground.
2. Place a wood block about 5 cm / 1.97 in high under the right pothole protection device.
3. Press the lift function button and try to lift the machine to a certain height.

Result: The pothole protection device touches the wooden block and cannot be fully unfolded. The diagnostic display does not display code 18. No alarm sounds and the machine can continue to be lifted. Adjust or replace the pothole protection limit switch.

4. Press the drive function selection button and try to drive and steer the machine.

Result: diagnostic display shows code 18, alarm sounds, and steering and drive functions can be operated. The machine functions normally.

Result: the diagnostic display does not display code 18, no alarm sounds, and the drive and steering functions of the machine are normal. Adjust or replace the pothole protection limit switch.

5. Lower the platform to the retracted and remove the wood block under the right pothole protection device.
6. Repeat steps 32 ~ 35 under the left pothole protection device.
7. Drop the platform to the retracted state, and remove the wood blocks under the left pothole protection device.
8. Shut down the machine.

Upper limit switch

1. This check is carried out every 25 hours or once a month, whichever comes first.
2. A good limit switch is essential for machine

performance and safe operation. Operating the machine with a defective limit switch will reduce machine performance and lead to potentially unsafe working environments.

3. To complete this function inspection, the machine must be placed on a solid, flat and barrier-free ground.

- 1) Turn the key switch to the ground control and lift the platform to a certain height from the ground. See Table "lifting height of each model".
- 2) Move the safety arm to the middle of the scissor shaft sleeve and rotate it down to the vertical state.
- 3) Lower the platform height until the safety arm is in full contact with the shaft sleeve.



**WARNING: Risk of crushing**

When the platform is lowered, make sure that the hands are in the correct position of the safety arm.

- 4) Open the limit switch base cover installed on the chassis.
- 5) Slightly lift the platform and restore the safety arm.
- 6) Press the upper limit switch arm while lifting the platform with the GCU to activate the upper limit switch.

Result: the platform stops rising and the machine functions normally.

Result: if the platform continues to rise, adjust or replace the upper limit switch.

## 9.10 Testing platform overload system

1. Perform this step every 50 hours or a quarter, whichever comes first, or immediately check and re-calibrate the machine when it has overload failure.

2. Frequent testing of the platform overload mechanism is critical to the safe operation of the machine. Continuous incorrect operation of the platform will cause the system failure to sense platform overload information. The stability of the machine will be affected, causing the equipment to roll over.

3. The platform overload system aims to prevent the machine from being operated under overload. It is composed of two electrical components: an overload pressure sensor and an angle sensor.

4. The angle sensor located in the inner scissor arm is used to measure the inclination angle of the scissor and thus to determine the height of the platform.

- 1) Turn the key switch to the ground control and lift the platform to a certain height from the ground. See Table "lifting height of each model".
- 2) Lift the safety arm, move the safety arm to the middle of the scissor shaft sleeve, and rotate it down to the vertical state.
- 3) Lower the platform height until the safety arm is in full contact with the shaft sleeve.



**WARNING: Risk of crushing**

When the platform is lowered, make sure that the hands are in the correct position of the safety arm.

- 4) Open the limit switch base cover installed on the chassis.
- 5) Remove the limit switch cap.
- 6) Short-circuit the limit switch with a wire so that the limit switch is normally closed.
- 7) Turn the key switch to the ground control, and pull out the two red emergency stop buttons on the PCU

and GCU

- 8) Slightly lift the platform and restore the safety arm.
- 9) After lifting the platform to the highest position, continue to press the lifting function selection button.

Result: the alarm sounds.

Result: no alarm sound. Calibrate the platform overload system.

5. Lower the platform to the retracted mode via the manual lowering function.
6. Carefully disassemble the short-circuited wire of the upper limit switch.
7. After lifting the platform to the highest position, continue to press the lifting function selection button.

Result: the alarm does not sound and the system functions are normal.

Result: the alarm sounds and the function of platform overload system is abnormal. Troubleshoot the limit switch, wires and mounting bracket of limit switch, etc., and be sure to calibrate the overload system.

8. Raise the platform to a certain height from the ground. The lifting heights are shown in the table "Lifting Height of Each Model".
9. Lift the safety arm, move the safety arm to the middle of the scissor shaft sleeve, and rotate it down to the vertical state.
10. Lower the platform height until the safety arm is in full contact with the shaft sleeve.



**WARNING:** Risk of crushing

When the platform is lowered, make sure that the hands are in the correct position of the safety arm.

11. Reinstall the limit switch cap as it is.
12. Reinstall the platform limit shield as it is.
13. Slightly lift the platform and restore the

safety arm.

14. Lower the platform to retraction position.

## 9.11 Test emergency lowering cable

Note: In case of main power supply or machine failure, pull the emergency lowering cable to lower the platform. The emergency lowering cable is connected to the barrel end of the lift cylinder and activated at the chassis.

1. Raise the platform to a certain height;
2. When the platform needs to be lowered in case of emergency, pull the emergency lowering cable to lower the machine. Release the cable when considerable resistance is felt.
3. If the machine has no action when you pull the cable, please check the cylinder valve block and cable immediately.



**WARNING:** Risk of crushing

When the platform is lowered, make sure that the hands are in the correct position of the safety arm.

## 9.12 Test of battery charging

1. Drive the whole machine to the charging test area and charge the whole machine.
2. Check whether the whole machine is charged normally: after the charger is connected to the power supply, the charger displays "AC, voltage, CPU, 0.07, charging program code, power percentage, voltage and current" in turn. During the test, check the display content of the charger and stop charging until the current is displayed. If the displayed current is not 0, it indicate the charging is normal. If there is any problem, record and feedback the problem.
3. Check whether the charging program display is correct, and if there is a problem, record and feed it back

Note: The machine is forbidden to work during charging.

## 9.13 Pressure parameter test

Pressure test parameter range:

Drive type	Vehicle model	System relief pressure (MPa/psi)(± 0.5MPa/72.5psi)	Lift relief pressure (MPa/psi)(± 0.5MPa/72.5psi)	Steering overflow pressure (MPa/psi)(± 0.5MPa/72.5psi)
Electric vehicle	S1932E II	-	17.5/2538	12/1740
	S2632E II	-	21/3046	15//2176
	S2646E II	-	21/3046	15/2176
	S3246E II	-	21/3046	15/2176
	S4046E II	-	21/3046	15/2176
	S4650E II	-	21/3046	16.5/2393
Hydraulically powered vehicle	S1932II	25/3626	19/2756	12/1740
	S2632 II	25/3626	21/3046	15/2176
	S2646 II	25/3626	21/3046	15/2176
	S3246 II	25/3626	21/3046	15/2176
	S4046 II	25/3626	21/3046	15/2176
	S4650 II	25/3626	21/3046	16.5/2393

### Lift relief pressure

1. The upper limit switch shall be short-circuited for measuring lift relief pressure;
2. Connect the pressure gauge to the main valve pressure tap (the vehicle without pressure tap shall be equipped with the pressure tap before testing), and lift the vehicle;
3. After lifting the vehicle to the limit, check the reading of pressure gauge and compare it with the standard value. If it is not within the standard range, adjust the lift relief pressure to the standard range.

### Steering relief pressure

1. Connect the pressure gauge to the main valve pressure tap (the vehicle without pressure tap shall be equipped with the pressure tap before testing), and carry out steering operation for the vehicle;
2. Turn the vehicle right completely and then compare the reading of the pressure gauge with the standard value. If it is not within the standard range, adjust the steering relief pressure to the standard range.

### System overflow pressure

1. Drive the vehicle to the position of the system pressure test tooling, with the front wheels on the tooling;
2. Connect the pressure gauge to the main valve pressure tap (during commissioning of the vehicle without pressure tap, the test shall be carried out after the pressure tap is assembled), and carry out traveling operation for the vehicle; During forward walking, check the measured value of the pressure gauge and compare it with the value in the standard range. If it is not within the standard range, adjust the relief pressure of the system to the standard range.

## Adjustment position schematic

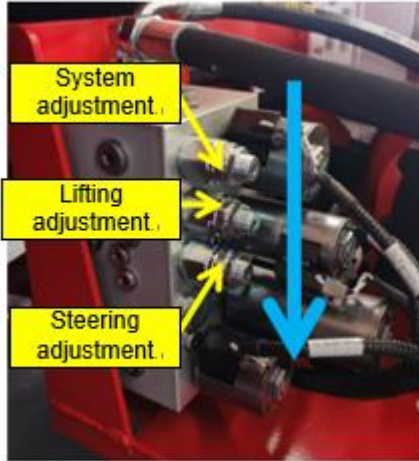

Fig. 9.9 Pressure regulation for relief valve of hydraulically-powered vehicle

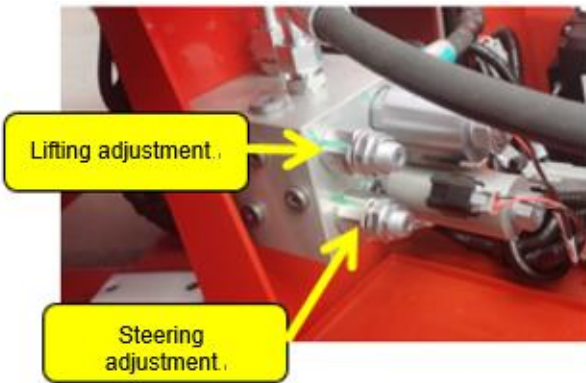

Fig. 9.10 Pressure regulation for relief valve of electric vehicle (except S1932E II)

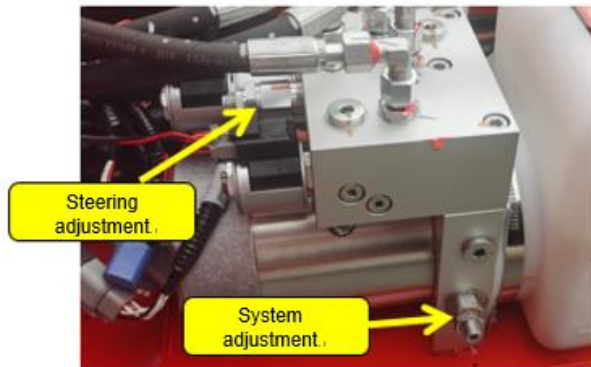

Fig. 9.11 S1932 E II relief valve pressure regulation

1. Adjust those not within the standard range according to the comparison between the measured relief pressure and the standard value

Each pressure corresponds to the adjustment

position, and the pressure shall be adjusted to the appropriate range with an Allen wrench.

### 9.14 Manual release valve function test (hydraulic drive)

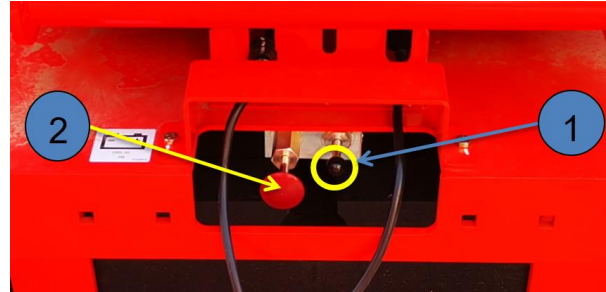

Fig. 9.12 Manual Release Valve

Brake release test:

1. Park the complete machine on the brake release test ramp:
  - 1) Press the brake release valve black valve block control button;
  - 2) Release the brake by the red hand valve until the red button can't be pressed;
  - 3) Check whether the vehicle can move at this time. If it can move, then it is conforming. If it cannot move, then make records and find the reasons; (The test can be carried out on the longitudinal level test ramp to check whether the vehicle can slide on the ramp)

Brake test: pull out the black handle to check whether the machine can brake reliably;

### 9.15 One-button brake release function test (electric drive)

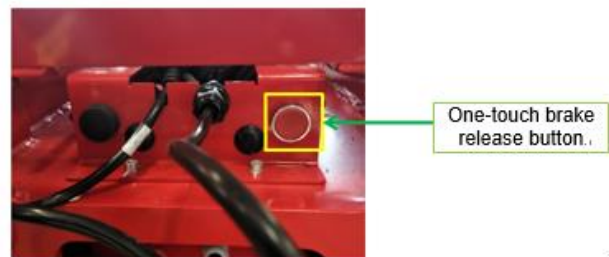

Fig. 9.13 One-button Brake Release Function

1. Brake release test: park the whole machine on the brake release test ramp

- a. Press the one-touch brake release red button on the rear side, after which the buzzer will beep continuously;
- b. Observe whether the vehicle will automatically move down the ramp;
- c. If it can move, it is conforming; if it can't move, make a record and find the reason (The test can be carried out on the longitudinal level test ramp to check whether the vehicle can slide on the ramp)

2. Brake test: press the red button again to check whether the machine can brake reliably.

### 9.16 Horizon sensor left and right inclination test



Fig. 9.14 Horizon sensor left and right inclination angle test

1. Before the inclination angle test, confirm that the inclination switch has a zeroing "OK" mark, and then perform the left and right inclination angle test. The left and right inclination angle test is 1.5°.
2. Lift the fork to be out of the lower limit position, test whether the buzzer gives an alarm. If it gives an alarm, the test is passed. If it does not give an alarm, it is necessary to adjust the chassis inclination switch until the test is passed;

### 9.17 Weighing calibration

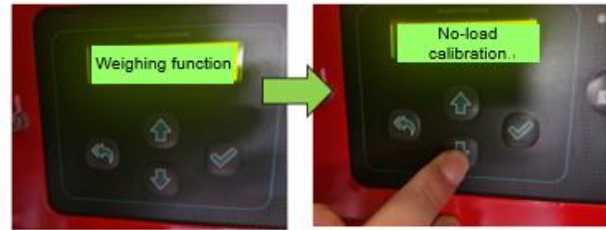

Fig. 9.15 No-load calibration

1. Park the vehicle in the no-load calibration and detection area, enter the ground control ECU system, and enable the weighing function;
2. Enter the no-load calibration interface, press and hold the relevant button 5 s to confirm the calibration process, and wait patiently for the calibration to be completed.

### 9.18 Overload calibration

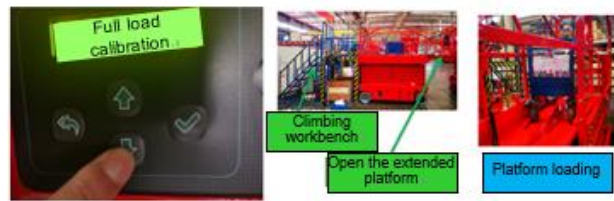

Fig. 9.16 Heavy load calibration

1. Park the vehicle in the heavy load calibration area, that is, in front of the climbing bench;
2. Open the extension platform, push the counterweight trolley from the climbing bench to the platform, and place it in the center;
3. Hang the trolley safety hook to the platform guardrail, and depress the trolley brake pedal;
4. Enter the heavy-load calibration interface, press and hold the relevant button for 5 s to confirm the calibration process, and wait patiently for the calibration to be completed;
5. Requirements for counterweight of each model: (heavy load calibration weight)

Vehicle model	Rated load (kg/lbs)	Overload calibration (kg/lbs)
S1932II	230/507	250/551
S1932E II	230/507	250/551
S2632 II	230/507	250/551
S2632E II	230/507	250/551

S2646 II	450/992	500/1102
S2646E II	450/992	500/1102
S3246 II	320/705	350/772
S3246E II	320/705	350/772
S4046 II	320/705	350/772
S4046E II	320/705	350/772
S4650 II	320/705	350/772
S4650E II	320/705	350/772

6. This calibration procedure is completed when the platform returns to the lowest position and the horn stops sounding.
7. If the calibration fails, the horn will sound many times and re-calibration must be carried out.
8. If the calibration is successful, the machine will enter the normal working state and have the normal weighing and detection function.
9. If the machine is worn and needs to be re-calibrated, please repeat the above process.











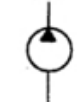
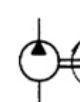

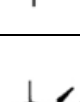
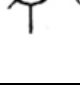

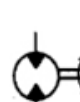
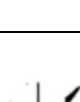
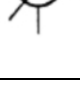







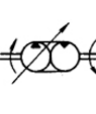













## Chapter 10 Appendix











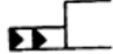

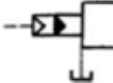
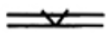
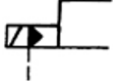

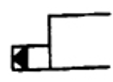
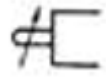
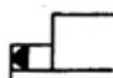
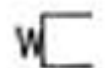
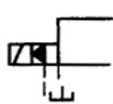



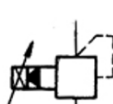
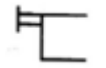
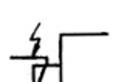
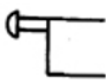
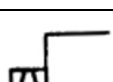
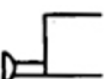



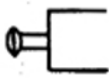

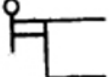
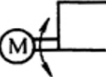
## 10.1 Schematic diagram of symbols of common hydraulic components

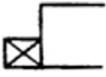

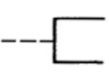

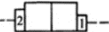
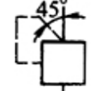
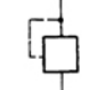
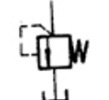

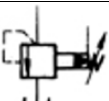
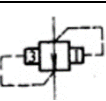
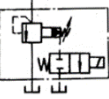
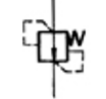
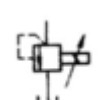

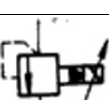
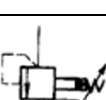

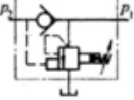
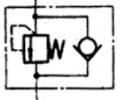
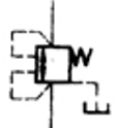
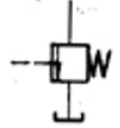

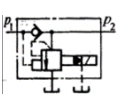

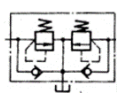
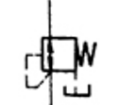
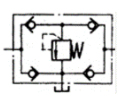

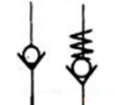
Symbols of common hydraulic components:

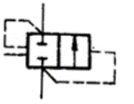

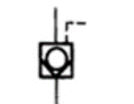



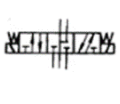
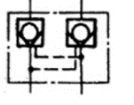



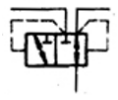

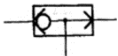



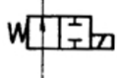

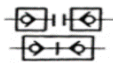

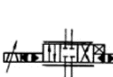
(1) Hydraulic pump, hydraulic motor and hydraulic cylinder						
Name		Symbol	Description	Name		Description
Hydraulic pump	Hydraulic pump		General symbol	Double-acting cylinder	Non-adjustable one-way bounce cylinder	Detailed symbol
	One-way fixed displacement hydraulic pump		One-way rotation, one-way flow and fixed displacement		Non-adjustable one-way bounce cylinder	Simplified symbol
	Two-way fixed displacement hydraulic pump		Two-way rotation, two-way flow, fixed displacement		Adjustable one-way bounce cylinder	Detailed symbol
	One-way variable hydraulic pump		One-way rotation, two-way flow, variable displacement		Adjustable one-way bounce cylinder	Simplified symbol
	Two-way variable displacement hydraulic pump		Two-way rotation, two-way flow, variable displacement		Non-adjustable two-way bounce cylinder	Detailed symbol
Hydraulic motor	Hydraulic motor		General symbol	Pressure converter	Non-adjustable two-way bounce cylinder	Simplified symbol
	One-way fixed displacement hydraulic motor		One-way flow, one-way rotation		Adjustable two-way bounce cylinder	Detailed symbol
	Two-way fixed displacement hydraulic motor		Two-way flow, two-way rotation, fixed displacement		Adjustable two-way bounce cylinder	Simplified symbol
	One-way variable displacement hydraulic motor		One-way flow, one-way rotation, variable displacement		Telescopic bar	
	One-way variable displacement hydraulic motor		Two-way flow, two-way rotation, variable displacement		Gas-liquid converter	One-way action

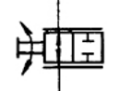
	Swing motor		Two-way swing, fixed angle				Continuous action
Pump-motor	Fixed displacement hydraulic pump-motor		One-way flow, one-way rotation, fixed displacement	Turbocharger			One-way action
	Variable displacement hydraulic pump-motor		Two-way flow, two-way rotation, variable displacement, external oil drain				Continuous action
	Hydraulic integral transmission		Unidirectional rotation, variable displacement, fixed displacement motor	Accumulator		General symbol	
Single-acting cylinder	Single piston rod cylinder		Detailed symbol	Accumulator			
			Simplified symbol				
	Single piston rod cylinder (with return spring)		Detailed symbol			Auxiliary gas cylinder	
			Simplified symbol				
	Plunger rod			Gas tank			
	Telescopic cylinder			Energy source			General symbol
Double-acting cylinder	Single piston rod cylinder		Detailed symbol				General symbol
			Simplified symbol				
Double piston rod cylinder	Double piston rod cylinder		Detailed symbol		Except motor		
			Simplified symbol				
(2) Mechanical control device and control methods							
Mechanical control parts	Straight moving rod		Arrows can be omitted	Pilot pressure control method	Hydraulic pilot pressure control		Internal pressure control
	Axle of rotary motion		Arrows can be omitted				External pressure control



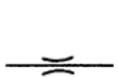

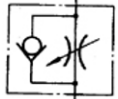
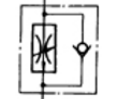
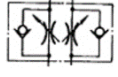

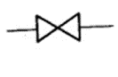
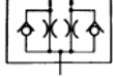
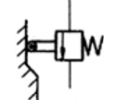
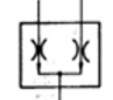



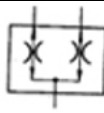
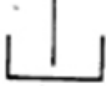

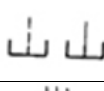

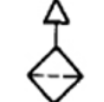

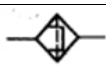

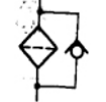

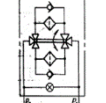
	Positioning device				Hydraulic secondary pilot pressure control		Internal pressure control, internal oil drain
	Locking device		* Control method for unlocking		Gas-liquid pilot pressure control		External control of air pressure, hydraulic internal control, external oil drain
	Bounce mechanism				Electro-hydraulic pilot pressure control		Hydraulic external control, internal oil drainage
	Ejector rod type				Hydraulic pilot pressure relief control		Internal pressure control, internal oil drain
	Variable travel control type				Hydraulic pilot pressure relief control		External pressure control (with remote relief outlet)
	Spring control type				Electro-hydraulic pilot control		Electromagnet control, external pressure control, external oil drain
	Roller type		Two-direction operation		Pilot pressure control valve		With pressure regulating spring, external oil drain and with remote relief outlet
	One-way roller type		It's only operated in one direction, so the arrow can be omitted.		Pilot proportional solenoid pressure control valve		Priority is controlled by proportional electromagnet with internal oil drainage
Manual control method	Manual control		General symbol	Electrical control method	Single-acting electromagnet		The electrical lead can be omitted, and the slash can also be directed to the lower right.
	Button type				Double-acting electromagnet		
	Button type				Single-acting adjustable electromagnetic operation (proportiona		



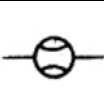
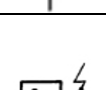

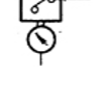
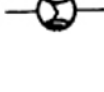
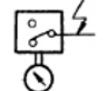

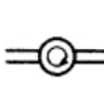

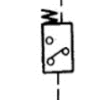

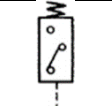
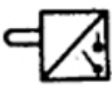

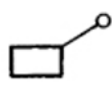

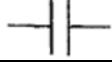

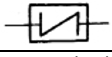
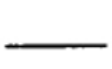
					I electromag net)		
	Press-pull type				Double- acting adjustable electromag netic operation (torque motor, etc.)		
	Handle type				Rotary motion electrical control device		
	One-way pedal type			Feedback control method	Feedback control		General symbol
	Two-way pedal type				Electrical feedback		The position is detected by potentiometer , differential transformer, etc.
	Pressurizati on or relief control				Internal mechanical feedback		Such as follower valve profiling control circuit
	Differential control						
	Internal pressure control		The control channel is inside the original				
	External pressure control		The control channel is outside the original				
(3) Pressure controller							
Relief valve	Relief valve		General symbols or direct- acting relief valve	Pressure reducing valve	Pilot proportional solenoid pressure reducing valve		
	Pilot relief valve				Proportional pressure reducing valve		Pressure reducing ratio: 1/3
	Pilot electromag netic relief valve		(Normally closed)		Constant difference pressure reducing valve		
	Direct- acting proportional relief valve			Sequence valve	Sequence valve		General symbols or harmonious- acting sequence valve
	Pilot proportional relief valve				Pilot sequence valve		

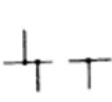
	Unloading relief valve		Unloading it when $p_2 > p_1$		One-way sequence valve (balance valve)		
	Two-way relief valve		Direct-acting, external oil drain	Unloading valve	Unloading valve		General symbols or direct-acting unloading valve
Pressure reducing valve	Pressure reducing valve		General symbols or direct-acting pressure reducing valve		Pilot electromagnetic unloading valve		$p_1 > p_2$
	Pilot pressure reducing valve			Brake valve	Double overflow brake valve		
	Relief pressure reducing valve				Overflow oil bridge brake valve		
(4) Directional control valve							
Check valve	Check valve		Detailed symbol		Two-position five-way hydraulic valve		
			Simplified symbol (spring can be omitted)		Two-position four-way motorized valve		
Hydraulic check valve	Hydraulically controlled check valve		Detailed symbol (controlling pressure shutoff valve)	Reversing valve	Three-position four-way solenoid valve		
			Simplified symbol		Three-position four-way electro-hydraulic valve		Simplified symbol (internal leakage and external control)
			Detailed symbol (controlling pressure opening valve)		Three-position six-way hand valve		
			Simplified symbol (spring can be omitted)		Three-position five-way solenoid valve		
	Double hydraulically controlled check valve				Three-position four-way electro-hydraulic valve		External control and internal leakage (with manual emergency control device)

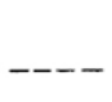
Shuttle valve	Or gate valve		Detailed symbol		Three-position four-way proportional valve		Throttling type, overlapped center
			Simplified symbol		Three-position four-way proportional valve		Underlapped center
Reversing valve	Two-position two-way solenoid valve		Normally closed		Two-position four-way proportional valve		
			Normally open		Four-way servo valve		
	Two-position three-way solenoid valve				Four-way electro-hydraulic servo valve		Level 2
	Two-position three-way solenoid ball valve						Live feedback level 3
	Two-position four-way solenoid valve						
(5) Flow control valve							
Throttle valve	Adjustable throttle valve		Detailed symbol		Flow regulating valve		Simplified symbol
			Simplified symbol		Bypass type flow regulating valve		Simplified symbol
	Non-adjustable throttle valve		General symbol	Flow regulating valve	Temperature compensated flow regulating valve		Simplified symbol
	One-way throttle valve			One-way flow regulating valve		Simplified symbol	
	Double one-way throttle valve			Synchronous valve	Flow divider valve		
	Stop valve				One-way flow divider valve		
	Roller-controlled throttle valve (deceleration valve)				Flow combiner valve		

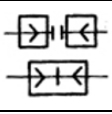

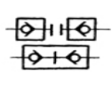









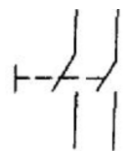
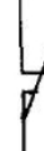
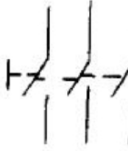
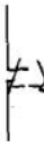

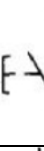
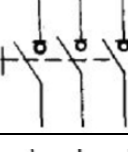
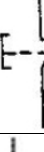
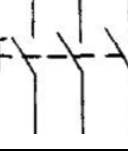
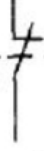
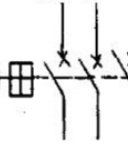

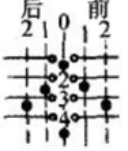
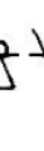
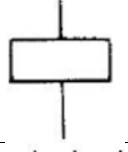





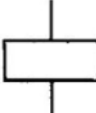

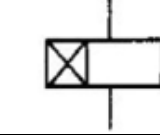

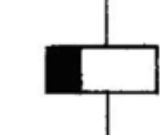
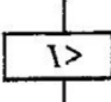

Flow regulating valve	Flow regulating valve		Detailed symbol		Diverter collector valve		
(6) Oil tank							
Atmospheric type	Pipe end above the liquid level			Oil tank	Pipe end at the bottom of the oil tank		
	Pipe end above the liquid level		With air cleaner		Local oil drain or return		
				Pressurized oil tank or closed oil tank			Three oil circuits
(7) Fluid regulator							
Filter	Filter		General symbol	Air cleaner			
	Filter with pollution indicator				Temperature regulator		
	Magnetic filter			Cooler	Cooler		General symbol
	Filter with bypass valve				Cooler to the coolant pipeline		
	Duplex filter		P1: oil inlet P2: oil return	Heater			General symbol
Pressure detector	Pressure indicator			Flow detector	Galvanometer (liquid flow indicator)		
	Pressure gauge				Flowmeter		
	Electric contact pressure gauge (pressure display controller)				Accumulated flowmeter		
	Differential pressure control gauge			Thermometer			
Level gauge				Tachometer			
				Torque meter			
(9) Other auxiliary components							
Pressure relay (pressure switch)			Detailed symbol	Differential pressure switch			

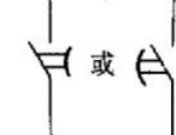
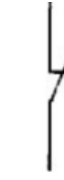

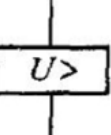

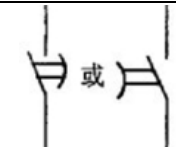

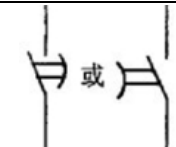

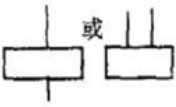
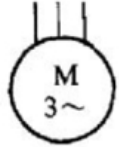
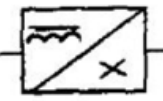

			General symbol					
Travel switch			Detailed symbol	Sensor	Sensor		General symbol	
			General symbol		Pressure sensor			
					Temperature sensor			
Coupling	Coupling		General symbol	Amplifier				
	Flexible coupling							
(10) Pipeline, pipeline joints and connectors								
Pipeline	Pipeline		Pressure pipeline and return pipeline	Pipeline	Cross pipeline		The two pipelines are crossed and unconnected	
	Control pipeline		Two pipelines intersected and connected		Flexible pipeline			
	Control pipeline		It can represent an oil draining pipeline		One-way air bleeder			
Quick-change connector	Quick connector without check valve			Rotary connector	Single-channel rotary connector			
	Quick connector with check valve				Three-way rotary connector			

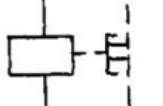
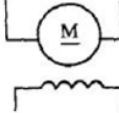
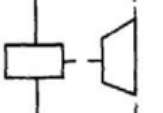
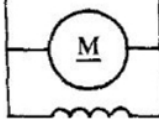
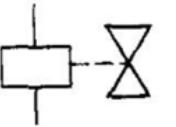
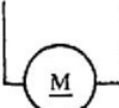
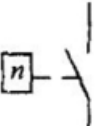
## 10.2 Schematic diagram of common electrical component symbols

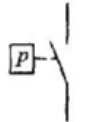
Common electrical component symbols:

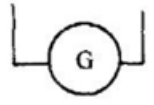
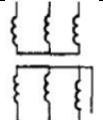
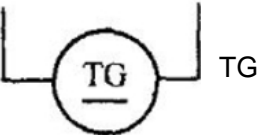
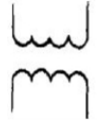
Socket	Name	Graphic symbol	Letter symbol	Category	Name	Graphic symbol	Letter symbol
Switch	Unipolar control switch		SA	Position switch	Normally open contact		SQ
	General symbols of manual switch		SA		Normally closed contact		SQ
	Three-level control switch		QS		Composite contact		SQ
	Three-level isolating switch		QS	Button	Normally open button		SB
	Three-level load switch		QS		Normally closed button		SB
	Combination knob switch		QS		Composite button		SB
	Low voltage circuit breaker		QF		Emergency stop button		SB
	Controller or operating switch		SA		Key-operated button		SB
Contactor	Coil operating device		KM	Thermal relay	Thermal element		FR
	Normally open main contact		KM		Normally closed contact		FR

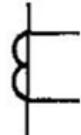
	Normally open auxiliary contact		KM	Intermediate relay	Coil		KA
	Normally closed auxiliary contact		KM		Normally open contact		KA
	Power-on delay (slow pull-in) coil		KT		Normally closed contact		KA
Time relay	Power-off delay (slow release) coil		KT	Current relay	Overcurrent coil		KA
	Normally open contact which is Instantaneously closed		KT		Undercurrent coil		KA
	Normally closed contact which is instantaneously disconnected		KT		Normally open contact		KA
	Normally open contact which is closed with delay		KT		Normally closed contact		KA
	Normally closed contact which is disconnected with delay		KT	Voltage relay	Overvoltage coil		KV
	Normally closed contact which is closed with delay		KT		Undervoltage coil		KV
	Normally open contact which is disconnected with delay		KT		Normally open contact		KV
	Normally open contact which is disconnected with delay		KT		Normally closed contact		KV

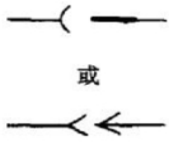
Electromagnetic operator	General symbol of electromagnetic		YA	Motor	Three-phase cage asynchronous motor		M
	Electromagnetic chuck		YH		Three-phase wound rotor asynchronous motor		M
	Electromagnetic clutch		YC		Separately excited DC motor		M
	Electromagnetic brake		YB		Shunt DC motor		M
	Solenoid valve		YV		Series DC motor		M
Non-electricity-controlled relay	Speed relay normally open contact		KS	Fuse	Fuse		FU
	Pressure relay normally open contact		KP	Transformer	Single-phase transformer		TC
Generator	Generator		G		Three-phase transformer		TM
	DC tachometer generator		TG	Transformer	Voltage transformer		TV
Lamp	Signal lamp (indicator lamp)		HL		Current transformer		TA
	Lighting lamp		EL	Connector	Plug and socket		X Plug XP Socket XS

## 10.3 Pipeline Connection Table

### 10.3.1 S1932 II Pipeline Connection Table

Serial number	Part Name	Connector Code	Connector Name	Pipeline Code	Line name	Connector Code	Connector Name	Part Name	Description
1	Brake release valve	4120001177	Joint GE08 L7/16 UNFOMDCF	4120705243	Hose F471 TCCACE080804-350-PG150	4120001177	Joint GE08 L7/16 UNFOMDCF	Brake disc	To left brake disc
2	Brake release valve	4120001177	Joint GE08 L7/16 UNFOMDCF	4120002633	Hose F471TCCACE080804-310-PG150	4120001177	Joint GE08 L7/16 UNFOMDCF	Brake disc	To right brake disc
3	Oil tank	4120709382	Joint GE12LM27X2EDOMDCF	4120709383	Rubber hose F481CACE121208-315	4120001224	Joint GE12LRED0MDCF	Main valve	To T1 port
4	Oil tank	4120704978	Connector GEO15 LM22 X1.5 OMD	4120709388	Hose F481CACF151510-215	4120002235	Joint GE15LRED0MDCF	Pump	
5	Brake release valve	4120001177	Joint GE08 L7/16 UNFOMDCF	4120705276	Hose F471TCCACF080804-1775	4120001170	Joint GE08 LRED0MDCF	Main valve	To port B R
6	Pump	4120001373	Joint GE12LR1/2EDOMDCF	4120705652	Rubber hose F471TCCACF121206-210	4120001224	Joint GE12LRED0MDCF	Main valve	To port P
7	Lift cylinder valve block port 1	4120001165	Joint GE10LR3/8EDOMDCF	4120705926	Rubber hose FC402CACA101005-3310 + PG1200	4120001165	Joint GE10LR3/8EDOMDCF	Main valve	To port CSE
8	Lift cylinder valve block port 2	4120001165	Joint GE10LR3/8EDOMDCF	4120705926	Rubber hose FC402CACA101005-3310 + PG1200	4120001165	Joint GE10LR3/8EDOMDCF	Main valve	To port T
9	Large cavity of steering cylinder	4120001177	Joint GE08 L7/16 UNFOMDCF	4120705199	Rubber hose F471 TCCACF080804-1100	4120001170	Joint GE08 LRED0MDCF	Main valve	To port AS
10	Steering cylinder small cavity	4120001177	Joint GE08 L7/16 UNFOMDCF	4120704860	Hose F471TCCACF080804-1200	4120001170	Joint GE08 LRED0MDCF	Main valve	Connected to port BS
11	Right walking motor	4120704977	Joint GE10L9/16UNFOMD	4120705273	Motor hose F471TCCACA101005-1400-PG435	4120001166	Joint EW10LOMDCF	Main valve	To port C
12	Right walking motor	4120704977	Joint GE10L9/16UNFOMD	4120706460	Motor hose F471TCCACA101005-1460-PG400	4120001165	Joint GE10LR3/8EDOMDCF	Main valve	To port B2
13	Left walking motor	4120704977	Joint GE10L9/16UNFOMD	4120706460	Motor hose F471TCCACA101005-1460-PG400	4120001165	Joint GE10LR3/8EDOMDCF	Main valve	To port B1
14	Left walking motor	4120704977	Joint GE10L9/16UNFOMD	4120705273	Motor hose F471TCCACA101005-1400-PG435	4120001168	Tee fitting EL10LOMDCF	Main valve	To lower part of port C

## 10.3.2 S1932E II pipeline connection table

Serial number	Part Name	Connector Code	Connector Name	Pipeline Code	Line name	Connector Code	Connector Name	Part Name	Description
1	Lift cylinder valve block	4120001391	Joint GE08LR3/8EDOMDCF	4120706651	Hose FC402 CACA080804-3500	4120001170	Joint GE08 LREDOMDCF	Power unit	To port CSE
2	Lift cylinder valve block	4120001391	Joint GE08LR3/8EDOMDCF	4120707849	Rubber hose FODCACA080804-3500	2507000870	Straight fitting M14-R 3/4	Filter	
	Filter	2507000870	Straight fitting M14-R 3/4	4120709614	Hose FODCACF080804-320	4120001170	Joint GE08 LREDOMDCF	Power unit	To port T
3	Steering cylinder	4120001170	Joint GE08 LREDOMDCF	4120705459	Hose F471 TCCACF080804-1300	4120001177	Joint GE08 L7/16 UNFOMDCF	Power unit	AS port
4	Steering cylinder	4120001170	Joint GE08 LREDOMDCF	4120705459	Hose F471 TCCACF080804-1300	4120001177	Joint GE08 L7/16 UNFOMDCF	Power unit	BS port

## 10.3.3 S2632 II pipeline wiring table

Serial number	Part Name	Connector Code	Connector Name	Pipeline Code	Line name	Connector Code	Connector Name	Part Name	Description
1	Brake release valve	4120001177	Joint GE08 L7/16 UNFOMDCF	4120705243	Hose F471 TCCACE080804-350-PG150	4120001177	Joint GE08 L7/16 UNFOMDCF	Brake disc	To left brake disc
2	Brake release valve	4120001177	Joint GE08 L7/16 UNFOMDCF	4120002633	Hose F471TCCACE080804-310-PG150	4120001177	Joint GE08 L7/16 UNFOMDCF	Brake disc	To right brake disc
3	Oil tank	2507000011	Return steel pipe assembly	4120705165	Rubber hose F481CACE121208-410	2507000009	Straight fitting	Filter	
4	Oil tank	4120704978	Connector GEO15 LM22 X1.5 OMD	4120001162	Hose F481 CACF151510-290	4120002235	Joint GE15LREDOMDCF	Pump	
5	Filter	2507000009	Straight fitting	4120705969	Rubber hose F481 CACF121208-370	4120001224	Joint GE12LREDOMDCF	Main valve	To T1 port
6	Brake release valve	4120001177	Joint GE08 L7/16 UNFOMDCF	4120706473	Hose F471 TCCACF080804-2400	4120001170	Joint GE08 LREDOMDCF	Main valve	To port B R
7	Pump	4120001373	Joint GE12LR1/2EDOMDCF	4120705167	Rubber hose F471 TCCACF121206-450	4120001224	Joint GE12LREDOMDCF	Main valve	To port P
8	Lift cylinder valve block	4120001165	Joint GE10LR3/8EDOMDCF	4120705970	Hose FC402 CACA101005-4130-PG900	4120001165	Joint GE10LR3/8EDOMDCF	Main valve	To port CSE
9	Lift cylinder	4120001165	Joint	4120705970	Hose FC402 CACA101005-4130-	4120001165	Joint	Main valve	To port T

	valve block		GE10LR3/8EDOMDCF		PG900		GE10LR3/8EDOMDCF		
10	Steering cylinder small cavity	4120001177	Joint GE08 L7/16 UNFOMDCF	4120705199	Rubber hose F471 TCCACF080804-1100	4120001170	Joint GE08 LREDOMDCF	Main valve	Connected to port BS
11	Large cavity of steering cylinder	4120001177	Joint GE08 L7/16 UNFOMDCF	4120704860	Hose F471TCCACF080804-1200	4120001170	Joint GE08 LREDOMDCF	Main valve	To port AS
12	Right walking motor	4120704977	Joint GE10L9/16UNFOMD	4120704988	Motor Hose F471 TCCACF101005-1315-PG420-Heightened	4120001168	Tee fitting EL10LOMDCF	Main valve	To port C
13	Right walking motor	4120704977	Joint GE10L9/16UNFOMD	4120704987	Motor Hose F471 TCCACF101005-1265-PG420-Heightened	4120001165	Joint GE10LR3/8EDOMDCF	Main valve	To port B2
14	Left walking motor	4120704977	Joint GE10L9/16UNFOMD	4120704986	Motor hose F471 TCCACF101005-1315-PG420	4120001165	Joint GE10LR3/8EDOMDCF	Main valve	To port B1
15	Left walking motor	4120704977	Joint GE10L9/16UNFOMD	4120704985	Motor hose F471 TCCACF101005-1240-PG420	4120001166	Joint EW10LOMDCF	Main valve	To lower part of port C

### 10.3.4 S2632 E II pipeline wiring table

Serial number	Part Name	Connector Code	Connector Name	Pipeline Code	Line name	Connector Code	Connector Name	Part Name	Description
1	Oil tank	2507000011	Return steel pipe assembly	4120705165	Rubber hose F481CACE121208-410	2507000009	Straight fitting	Filter	
2	Oil tank	4120707646	Suction connector	4120001162	Hose F481 CACF151510-290	4120002235	Joint GE15LREDOMDCF	Pump	
3	Filter	2507000009	Straight fitting	4120705969	Rubber hose F481 CACF121208-370	4120001224	Joint GE12LREDOMDCF	Main valve	To T1 port
4	Pump	4120001373	Joint GE12LR1/2EDOMDCF	4120705167	Hose F471 TCCACF121206-450	4120001224	Joint GE12LREDOMDCF	Main valve	To port P
5	Lift cylinder valve block	4120001165	Joint GE10LR3/8EDOMDCF	4120705970	Hose FC402 CACA121206-4350	4120001165	Joint GE12LREDOMDCF	Main valve	To port CSE
6	Lift cylinder valve block	4120001165	Joint GE10LR3/8EDOMDCF	4120705970	Hose FC402 CACA121206-4350	4120001165	Joint GE12LREDOMDCF	Main valve	Connect to T1
7	Steering cylinder small cavity	4120001177	Joint GE08 L7/16 UNFOMDCF	4120704860	Hose F471TCCACF080804-1200	4120001170	Joint GE08 LREDOMDCF	Main valve	Connected to port BS
8	Large cavity of steering cylinder	4120001177	Joint GE08 L7/16 UNFOMDCF	4120705199	Rubber hose F471 TCCACF080804-1100	4120001170	Joint GE08 LREDOMDCF	Main valve	To port AS



## 10.3.5 S2646 II pipeline wiring table

Serial number	Part Name	Connector Code	Connector Name	Pipeline Code	Line name	Connector Code	Connector Name	Part Name	Description
1	Brake release valve	4120001177	Joint GE08 L7/16 UNFOMDCF	4120002637	Hose F471 TCCACE080804-500-PG300	4120001177	Joint GE08 L7/16 UNFOMDCF	Brake disc	To left brake disc
2	Brake release valve	4120001177	Joint GE08 L7/16 UNFOMDCF	4120002637	Hose F471 TCCACE080804-500-PG300	4120001177	Joint GE08 L7/16 UNFOMDCF	Brake disc	To right brake disc
3	Oil tank	2507000011	Return steel pipe assembly	4120705165	Rubber hose F481CACE121208-410	2507000009	Straight fitting	Filter	
4	Oil tank	4120704978	Connector GEO15 LM22 X1.5 OMD	4120001162	Hose F481 CACF151510-290	4120002235	Joint GE15LREDOMDCF	Pump	
5	Filter	2507000009	Straight fitting	4120705166	Rubber hose F481 CACF121208-440	4120001224	Joint GE12LREDOMDCF	Main valve	To T1 port
6	Brake release valve	4120001177	Joint GE08 L7/16 UNFOMDCF	4120704859	Hose F471 TCCACF080804-2400	4120001170	Joint GE08 LREDOMDCF	Main valve	To port B R
7	Pump	4120001373	Joint GE12LR1/2EDOMDCF	4120705167	Rubber hose F471 TCCACF121206-450	4120001224	Joint GE12LREDOMDCF	Main valve	To port P
8	Lift cylinder valve block	4120001224	Joint GE12LREDOMDCF	4120704861	Hose FC402 CACA121206-4350	4120001224	Joint GE12LREDOMDCF	Main valve	To port CSE
9	Lift cylinder valve block	4120001166	Joint EW10LOMDCF	4120705175	Rubber hose FC402 CACF081004-850	4120001170	Joint GE08 LREDOMDCF	Lift cylinder small cavity	
10	Lift cylinder valve block	4120001224	Joint GE12LREDOMDCF	4120704861	Hose FC402 CACA121206-4350	4120001224	Joint GE12LREDOMDCF	Main valve	To port T
11	Steering cylinder small cavity	4120001177	Joint GE08 L7/16 UNFOMDCF	4120704860	Hose F471TCCACF080804-1200	4120001170	Joint GE08 LREDOMDCF	Main valve	Connected to port BS
12	Large cavity of steering cylinder	4120001177	Joint GE08 L7/16 UNFOMDCF	4120704860	Hose F471TCCACF080804-1200	4120001170	Joint GE08 LREDOMDCF	Main valve	To port AS
13	Right walking motor	4120704977	Joint GE10L9/16UNFOMD	4120705171	Motor rubber hose F471 TCCACE101005-1600-PG500	4120001165	Joint GE10LR3/8EDOMDCF	Main valve	Connect to port C2
14	Right walking motor	4120704977	Joint GE10L9/16UNFOMD	4120705172	Motor rubber hose F471 TCCACE101005-1690-PG500	4120001165	Joint GE10LR3/8EDOMDCF	Main valve	To port B2
15	Left walking motor	4120704977	Joint GE10L9/16UNFOMD	4120705170	Motor rubber hose F471 TCCACE101005-1640-PG500	4120001165	Joint GE10LR3/8EDOMDCF	Main valve	To port B1
16	Left walking motor	4120704977	Joint GE10L9/16UNFOMD	4120705169	Motor rubber hose F471 TCCACE101005-1620-PG500	4120001165	Joint GE10LR3/8EDOMDCF	Main valve	Connect to C1 port

### 10.3.6 S2646 E II Pipeline wiring table

Serial number	Part Name	Connector Code	Connector Name	Pipeline Code	Line name	Connector Code	Connector Name	Part Name	Description
1	Oil tank	2507000011	Return steel pipe assembly	4120705165	Rubber hose F481CACE121208-410	2507000009	Straight fitting	Filter	
2	Oil tank	4120704978	Connector GEO15 LM22 X1.5 OMD	4120001162	Hose F481 CACF151510-290	4120002235	Joint GE15LREDOMDCF	Pump	
3	Filter	2507000009	Straight fitting	4120706472	Rubber hose F481 CACF121208-235	4120001224	Joint GE12LREDOMDCF	Main valve	To T1 port
4	Pump	4120001373	Joint GE12LR1/2EDOMDCF	4120705167	Hose F471 TCCACF121206-450	4120001224	Joint GE12LREDOMDCF	Main valve	To port P
5	Lift cylinder valve block	4120001224	Joint GE12LREDOMDCF	4120704861	Hose FC402 CACA121206-4350	4120001224	Joint GE12LREDOMDCF	Main valve	To port CSE
6	Lift cylinder valve block	4120001166	Joint EW10LOMDCF	4120705175	Rubber hose FC402 CACF081004-850	4120001170	Joint GE08 LREDOMDCF	Lift cylinder small cavity	
7	Lift cylinder valve block	4120001224	Joint GE12LREDOMDCF	4120704861	Hose FC402 CACA121206-4350	4120001224	Joint GE12LREDOMDCF	Main valve	To port T
8	Steering cylinder small cavity	4120001177	Joint GE08 L7/16 UNFOMDCF	4120704860	Hose F471TCCACF080804-1200	4120001170	Joint GE08 LREDOMDCF	Main valve	Connected to port BS
9	Large cavity of steering cylinder	4120001177	Joint GE08 L7/16 UNFOMDCF	4120704860	Hose F471TCCACF080804-1200	4120001170	Joint GE08 LREDOMDCF	Main valve	To port AS

### 10.3.7 S3246 II Pipeline wiring table

Serial number	Part Name	Connector Code	Connector Name	Pipeline Code	Line name	Connector Code	Connector Name	Part Name	Description
1	Brake release valve	4120001177	Joint GE08 L7/16 UNFOMDCF	4120002637	Hose F471 TCCACE080804-500-PG300	4120001177	Joint GE08 L7/16 UNFOMDCF	Brake disc	To left brake disc
2	Brake release valve	4120001177	Joint GE08 L7/16 UNFOMDCF	4120002637	Hose F471 TCCACE080804-500-PG300	4120001177	Joint GE08 L7/16 UNFOMDCF	Brake disc	To right brake disc
3	Oil tank	2507000011	Return steel pipe assembly	4120705165	Rubber hose F481CACE121208-410	2507000009	Straight fitting	Filter	
4	Oil tank	4120704978	Connector GEO15	4120001162	Hose F481 CACF151510-290	4120002235	Joint	Pump	

			LM22 X1.5 OMD				GE15LREDO MDCF		
5	Filter	2507000009	Straight fitting	4120705166	Rubber hose F481 CACF121208-440	4120001224	Joint GE12LREDO MDCF	Main valve	To T1 port
6	Brake release valve	4120001177	Joint GE08 L7/16 UNFOMDCF	4120704859	Hose F471 TCCACF080804-2400	4120001170	Joint GE08 LREDO MDCF	Main valve	To port B R
7	Pump	4120001373	Joint GE12LR1/2EDOMDC F	4120705167	Rubber hose F471 TCCACF121206-450	4120001224	Joint GE12LREDO MDCF	Main valve	To port P
8	Lower lift cylinder valve block	4120001224	Joint GE12LREDO MDCF	4120704861	Hose FC402 CACA121206-4350- PG2000	4120001224	Joint GE12LREDO MDCF	Main valve	To port CSE
9	Lower lift cylinder	4120001224	Joint GE12LREDO MDCF	4120704861	Hose FC402 CACA121206-4350- PG2000	4120001224	Joint GE12LREDO MDCF	Main valve	To port T
10	Lower lift cylinder valve block	4120001168	Tee fitting EL10LO MDCF	4120705175	Rubber hose FC402 CACF081004-850	4120001170	Joint GE08 LREDO MDCF	Lower lift cylinder small cavity	
	Upper lift cylinder valve block	4120001165	Joint GE10LR3/8EDOMDC F	4120705174	Hose FC402 CACA101005-7830- PG2890	4120001165	Joint GE10LR3/8EDOMD CF	Lower cylinder valve block	
	Upper lift cylinder small cavity	4120001170	Joint GE08 LREDO MDCF	4120705173	Hose FC402CACA100805-8550- PG2890	4120001165	Joint GE10LR3/8EDOMD CF	Lower cylinder valve block	
11	Steering cylinder small cavity	4120001177	Joint GE08 L7/16 UNFOMDCF	4120704860	Hose F471TCCACF080804-1200	4120001170	Joint GE08 LREDO MDCF	Main valve	Connecte d to port BS
12	Large cavity of steering cylinder	4120001177	Joint GE08 L7/16 UNFOMDCF	4120704860	Hose F471TCCACF080804-1200	4120001170	Joint GE08 LREDO MDCF	Main valve	To port AS
13	Right walking motor	4120704977	Joint GE10LR3/8EDOMD CF	4120705171	Motor rubber hose F471 TCCACE101005-1600-PG500	4120001165	Joint GE10LR3/8EDOMD CF	Main valve	Connect to port C2
14	Right walking motor	4120704977	Joint GE10LR3/8EDOMD CF	4120705172	Motor rubber hose F471 TCCACE101005-1690-PG500	4120001165	Joint GE10LR3/8EDOMD CF	Main valve	To port B2
15	Left walking m otor	4120704977	Joint GE10LR3/8EDOMD CF	4120705170	Motor rubber hose F471 TCCACE101005-1640-PG500	4120001165	Joint GE10LR3/8EDOMD CF	Main valve	To port B1
16	Left walking m otor	4120704977	Joint GE10LR3/8EDOMD CF	4120705169	Motor rubber hose F471 TCCACE101005-1620-PG500	4120001165	Joint GE10LR3/8EDOMD CF	Main valve	Connect to C1 port

### 10.3.8 S3246E II Pipeline Wiring Table

Serial number	Part Name	Connector Code	Connector Name	Pipeline Code	Line name	Connector Code	Connector Name	Part Name	Description
1	Oil tank	2507000011	Return steel pipe assembly	4120705165	Rubber hose F481CACE121208-410	2507000009	Straight fitting	Filter	
2	Oil tank	4120704978	Connector GEO15 LM22 X1.5 OMD	4120001162	Hose F481 CACF151510-290	4120002235	Joint GE15LREDOMDCF	Pump	
3	Filter	2507000009	Straight fitting	4120706472	Rubber hose F481 CACF121208-235	4120001224	Joint GE12LREDOMDCF	Main valve	To T1 port
4	Pump	4120001373	Joint GE12LR1/2EDOMDCF	4120705167	Hose F471 TCCACF121206-450	4120001224	Joint GE12LREDOMDCF	Main valve	To port P
5	Lower lift cylinder valve block	4120001224	Joint GE12LREDOMDCF	4120704861	Hose FC402 CACA121206-4350-PG2000	4120001224	Joint GE12LREDOMDCF	Main valve	To port CSE
6	Lower lift cylinder	4120001224	Joint GE12LREDOMDCF	4120704861	Hose FC402 CACA121206-4350-PG2000	4120001224	Joint GE12LREDOMDCF	Main valve	To port T
7	Lower lift cylinder valve block	4120001168	Tee fitting EL10LOMDCF	4120705175	Rubber hose FC402 CACF081004-850	4120001170	Joint GE08 LREDOMDCF	Lower lift cylinder small cavity	
8	Upper lift cylinder valve block	4120001165	Joint GE10LR3/8EDOMDCF	4120705174	Hose FC402 CACA101005-7830-PG2890	4120001165	Joint GE10LR3/8EDOMDCF	Lower cylinder valve block	
9	Upper lift cylinder small cavity	4120001170	Joint GE08 LREDOMDCF	4120705173	Hose FC402CACA100805-8550-PG2890	4120001165	Joint GE10LR3/8EDOMDCF	Lower cylinder valve block	
10	Steering cylinder small cavity	4120001177	Joint GE08 L7/16 UNFOMDCF	4120704860	Hose F471TCCACF080804-1200	4120001170	Joint GE08 LREDOMDCF	Main valve	Connected to port BS
11	Large cavity of steering cylinder	4120001177	Joint GE08 L7/16 UNFOMDCF	4120704860	Hose F471TCCACF080804-1200	4120001170	Joint GE08 LREDOMDCF	Main valve	To port AS

### 10.3.9 S4046 II Pipeline wiring table

Serial number	Part Name	Connector Code	Connector Name	Pipeline Code	Line name	Connector Code	Connector Name	Part Name	Description
1	Brake release valve	4120001177	Joint GE08 L7/16 UNFOMDCF	4120002637	Hose F471 TCCACE080804-500-PG300	4120001177	Joint GE08 L7/16 UNFOMDCF	Brake disc	To left brake disc
2	Brake release valve	4120001177	Joint GE08 L7/16 UNFOMDCF	4120002637	Hose F471 TCCACE080804-500-PG300	4120001177	Joint GE08 L7/16 UNFOMDCF	Brake disc	To right brake

									disc
3	Oil tank	2507000011	Return steel pipe assembly	4120705165	Rubber hose F481CACE121208-410	2507000009	Straight fitting	Filter	
4	Oil tank	4120704978	Connector GEO15 LM22 X1.5 OMD	4120001162	Hose F481 CACF151510-290	4120002235	Joint GE15LREDOMDCF	Pump	
5	Filter	2507000009	Straight fitting	4120705166	Rubber hose F481 CACF121208-440	4120001224	Joint GE12LREDOMDCF	Main valve	To T1 port
6	Brake release valve	4120001177	Joint GE08 L7/16 UNFOMDCF	4120704859	Hose F471 TCCACF080804-2400	4120001170	Joint GE08 LREDOMDCF	Main valve	To port B R
7	Pump	4120001373	Joint GE12LR1/2EDOMDCF	4120705167	Rubber hose F471 TCCACF121206-450	4120001224	Joint GE12LREDOMDCF	Main valve	To port P
8	Lower lift cylinder valve block	4120001224	Joint GE12LREDOMDCF	4120704861	Hose FC402 CACA121206-4350-PG2000	4120001224	Joint GE12LREDOMDCF	Main valve	To port CSE
9	Lower lift cylinder	4120001224	Joint GE12LREDOMDCF	4120704861	Hose FC402 CACA121206-4350-PG2000	4120001224	Joint GE12LREDOMDCF	Main valve	To port T
10	Lower lift cylinder valve block	4120001168	Tee fitting EL10LOMDCF	4120705175	Rubber hose FC402 CACF081004-850	4120001170	Joint GE08 LREDOMDCF	Lower lift cylinder small cavity	
	Upper lift cylinder valve block	4120001165	Joint GE10LR3/8EDOMDCF	4120705174	Hose FC402 CACA101005-7830-PG2890	4120001165	Joint GE10LR3/8EDOMDCF	Lower cylinder valve block	
	Upper lift cylinder small cavity	4120001170	Joint GE08 LREDOMDCF	4120705173	Hose FC402CACA100805-8550-PG2890	4120001165	Joint GE10LR3/8EDOMDCF	Lower cylinder valve block	
11	Steering cylinder small cavity	4120001177	Joint GE08 L7/16 UNFOMDCF	4120704860	Hose F471TCCACF080804-1200	4120001170	Joint GE08 LREDOMDCF	Main valve	Connecte d to port BS
12	Large cavity of steering cylinder	4120001177	Joint GE08 L7/16 UNFOMDCF	4120704860	Hose F471TCCACF080804-1200	4120001170	Joint GE08 LREDOMDCF	Main valve	To port AS
13	Right walking motor	4120704977	Joint GE10LR3/8EDOMDCF	4120705171	Motor rubber hose F471 TCCACE101005-1600-PG500	4120001165	Joint GE10LR3/8EDOMDCF	Main valve	Connect to port C2
14	Right walking motor	4120704977	Joint GE10LR3/8EDOMDCF	4120705172	Motor rubber hose F471 TCCACE101005-1690-PG500	4120001165	Joint GE10LR3/8EDOMDCF	Main valve	To port B2
15	Left walking motor	4120704977	Joint GE10LR3/8EDOMDCF	4120705170	Motor rubber hose F471 TCCACE101005-1640-PG500	4120001165	Joint GE10LR3/8EDOMDCF	Main valve	To port B1
16	Left walking motor	4120704977	Joint GE10LR3/8EDOMDCF	4120705169	Motor rubber hose F471 TCCACE101005-1620-PG500	4120001165	Joint GE10LR3/8EDOMDCF	Main valve	Connect to C1 port

### 10.3.10 S4046E II Pipeline Wiring Table

Serial number	Part Name	Connector Code	Connector Name	Pipeline Code	Line name	Connector Code	Connector Name	Part Name	Description
1	Oil tank	2507000011	Return steel pipe assembly	4120705165	Rubber hose F481CACE121208-410	2507000009	Straight fitting	Filter	
2	Oil tank	4120704978	Connector GEO15 LM22 X1.5 OMD	4120001162	Hose F481 CACF151510-290	4120002235	Joint GE15LREDOMDCF	Pump	
3	Filter	2507000009	Straight fitting	4120706472	Rubber hose F481 CACF121208-235	4120001224	Joint GE12LREDOMDCF	Main valve	To T1 port
4	Pump	4120001373	Joint GE12LR1/2EDOMDCF	4120705167	Hose F471 TCCACF121206-450	4120001224	Joint GE12LREDOMDCF	Main valve	To port P
5	Lower lift cylinder valve block	4120001224	Joint GE12LREDOMDCF	4120704861	Hose FC402 CACA121206-4350-PG2000	4120001224	Joint GE12LREDOMDCF	Main valve	To port CSE
6	Lower lift cylinder	4120001224	Joint GE12LREDOMDCF	4120704861	Hose FC402 CACA121206-4350-PG2000	4120001224	Joint GE12LREDOMDCF	Main valve	To port T
7	Lower lift cylinder valve block	4120001168	Tee fitting EL10LOMDCF	4120705175	Rubber hose FC402 CACF081004-850	4120001170	Joint GE08 LREDOMDCF	Lower lift cylinder small cavity	
8	Upper lift cylinder valve block	4120001165	Joint GE10LR3/8EDOMDCF	4120705174	Hose FC402 CACA101005-7830-PG2890	4120001165	Joint GE10LR3/8EDOMDCF	Lower cylinder valve block	
9	Upper lift cylinder small cavity	4120001170	Joint GE08 LREDOMDCF	4120705173	Hose FC402CACA100805-8550-PG2890	4120001165	Joint GE10LR3/8EDOMDCF	Lower cylinder valve block	
10	Steering cylinder small cavity	4120001177	Joint GE08 L7/16 UNFOMDCF	4120704860	Hose F471TCCACF080804-1200	4120001170	Joint GE08 LREDOMDCF	Main valve	Connected to port BS
11	Large cavity of steering cylinder	4120001177	Joint GE08 L7/16 UNFOMDCF	4120704860	Hose F471TCCACF080804-1200	4120001170	Joint GE08 LREDOMDCF	Main valve	To port AS

### 10.3.11 S4650 II Pipeline Wiring Table

Serial number	Part Name	Connector Code	Connector Name	Pipeline Code	Line name	Connector Code	Connector Name	Part Name	Description
1	Brake release valve	4120001177	Joint GE08 L7/16 UNFOMDCF	4120002315	Hose F471TCCACF080804-400-PG150	4120001177	Joint GE08 L7/16 UNFOMDCF	Brake disc	To left brake disc
2	Brake release valve	4120001177	Joint GE08 L7/16 UNFOMDCF	4120704860	Hose F471TCCACF080804-1200	4120001177	Joint GE08 L7/16 UNFOMDCF	Brake disc	To right brake

									disc
3	Oil tank	2507000072	Return steel pipe assembly	4120705902	Hose F481CACA121208-620	2507000009	Straight fitting	Filter	
4	Oil tank	4120707646	Suction connector	4120705971	Hose F481CACF151510-420	4120002235	Joint GE15LREDOMDCF	Pump	
5	Filter	2507000009	Straight fitting	4120708722	Hose F481CACF121208-500	4120001224	Joint GE12LREDOMDCF	Main valve	To T1 port
6	Brake release valve	4120001177	Joint GE08 L7/16 UNFOMDCF	4120705469	Hose F471TCCACE080804-3200	4120001170	Joint GE08 LREDOMDCF	Main valve	To port B R
7	Pump	4120002235	Joint GE15LREDOMDCF	4120705971	Hose F481CACF151510-420	4120001224	Joint GE12LREDOMDCF	Main valve	To port P
8	Lower lift cylinder valve block	4120001224	Joint GE12LREDOMDCF	4120705943	Hose FC402CACA121206-4800-PG1300	4120001224	Joint GE12LREDOMDCF	Main valve	To port CSE
9	Lower lift cylinder valve block	4120001224	Joint GE12LREDOMDCF	4120705943	Hose FC402CACA121206-4800-PG1300	4120001224	Joint GE12LREDOMDCF	Main valve	To port T
10	Lower lift cylinder valve block	4120001168	Tee fitting EL10LOMDCF	4120705461	Hose FC402CACF101005-1050	-	Lower lift cylinder small cavity	Lower lift cylinder small cavity	
	Upper lift cylinder valve block	4120001224	Joint GE12LREDOMDCF	4120705942	Hose FC402CACA121205-7900-PG2550	4120001224	Joint GE12LREDOMDCF	Lower cylinder valve block	
	Upper lift cylinder small cavity	4120001188	Joint GE10LREDOMDCF	4120705941	Hose FC402CACA101005-8900-PG2550	4120001165	Joint GE10LR3/8EDOMDCF	Lower cylinder valve block	
11	Steering cylinder small cavity	4120001177	Joint GE08 L7/16 UNFOMDCF	4120705459	Hose F471TCCACF080804-1200	4120001170	Joint GE08 LREDOMDCF	Main valve	Connected to port BS
12	Large cavity of steering cylinder	4120001177	Joint GE08 L7/16 UNFOMDCF	4120705459	Hose F471TCCACF080804-1200	4120001170	Joint GE08 LREDOMDCF	Main valve	To port AS
13	Right walking motor	4190000147	Joint GE12L9/16UNF0MD A3C	4120705472	Hose F471TCCACE121206-1800-PG750	4120001224	Joint GE12LREDOMDCF	Main valve	Connect to port C2
14	Right walking motor	4190000147	Joint GE12L9/16UNF0MD A3C	4120705472	Hose F471TCCACE121206-1800-PG750	4120001224	Joint GE12LREDOMDCF	Main valve	To port B2
15	Left walking motor	4190000147	Joint GE12L9/16UNF0MD A3C	4120705170	Hose F471TCCACE121206-1800-PG750	4120001224	Joint GE12LREDOMDCF	Main valve	To port B1
16	Left walking motor	4190000147	Joint GE12L9/16UNF0MD A3C	4120002355	Motor rubber hose F471TCCACE121206-1700	4120001224	Joint GE12LREDOMDCF	Main valve	Connect to C1 port

10.3.12 S4650E II Pipeline Wiring Table

Serial number	Part Name	Connector Code	Connector Name	Pipeline Code	Line name	Connector Code	Connector Name	Part Name	Description
1	Oil tank	2507000072	Return steel pipe assembly	4120705902	Hose F481CACA121208-620	2507000009	Straight fitting	Filter	
2	Oil tank	4120707646	Suction connector	4120705971	Hose F481CACF151510-420	4120002235	Joint GE15LREDOMDCF	Pump	
3	Filter	2507000009	Straight fitting	4120708722	Hose F481CACF121208-500	4120001224	Joint GE12LREDOMDCF	Main valve	To T1 port
4	Pump	4120001373	Joint GE12LR1/2EDOMDCF	4120706474	Hose F471 TCCACF121206-450	4120001224	Joint GE12LREDOMDCF	Main valve	To port P
5	Lower lift cylinder valve block	4120001224	Joint GE12LREDOMDCF	4120705943	Hose FC402CACA121206-4800-PG1300	4120001224	Joint GE12LREDOMDCF	Main valve	To port CSE
6	Lower lift cylinder valve block	4120001224	Joint GE12LREDOMDCF	4120705943	Hose FC402CACA121206-4800-PG1300	4120001224	Joint GE12LREDOMDCF	Main valve	To port T
7	Lower lift cylinder valve block	4120001168	Tee fitting EL10LOMDCF	4120705461	Hose FC402CACF101005-1050	-	Lower lift cylinder small cavity	Lower lift cylinder small cavity	
8	Upper lift cylinder valve block	4120001224	Joint GE12LREDOMDCF	4120705942	Hose FC402CACA121205-7900-PG2550	4120001224	Joint GE12LREDOMDCF	Lower cylinder valve block	
9	Upper lift cylinder small cavity	4120001188	Joint GE10LREDOMDCF	4120705941	Hose FC402CACA101005-8900-PG2550	4120001165	Joint GE10LR3/8EDOMDCF	Lower cylinder valve block	
10	Steering cylinder	4120001177	Joint GE08 L7/16 UNFOMDCF	4120705459	Hose F471 TCCACF080804-1300	4120001170	Joint GE08 LREDOMDCF	Main valve	Connected to port BS
11	Steering cylinder	4120001177	Joint GE08 L7/16 UNFOMDCF	4120705459	Hose F471 TCCACF080804-1300	4120001170	Joint GE08 LREDOMDCF	Main valve	To port AS